

GENERAL NOTES

- 1. TOPOGRAPHIC AND EXISTING CONDITIONS PER CITY GIS DATA AND SUPPLEMENTED WITH LANDMARK CONSULTANTS, INC. SURVEY FIELD DATA.
2. PROJECT BENCHMARK: NO. 5 REBAR WITH ALUMINUM CAP STAMPED 'LANDMARK LS 29039' LOCATED ON THE SOUTH PROPERTY LINE OF LOT 1, WORLD WEST SUBDIVISION, NORTH OF CURVE COURT, ELEVATION = 6667.80 (NAVD 88)
3. CITY OF STEAMBOAT SPRINGS PLAN REVIEW AND APPROVAL IS ONLY FOR GENERAL CONFORMANCE WITH CITY DESIGN CRITERIA AND THE CITY CODE. THE CITY IS NOT RESPONSIBLE FOR THE COMPLETENESS, ACCURACY AND ADEQUACY OF THE DRAWINGS, DESIGN, DIMENSIONS, AND ELEVATIONS SHALL BE CONFIRMED AND CORRELATED AT THE JOB SITE.
4. ONE COPY OF THE APPROVED CONSTRUCTION PLANS AND SPECIFICATIONS SHALL BE KEPT ON THE JOB SITE AT ALL TIMES. PRIOR TO THE START OF CONSTRUCTION, VERIFY WITH PROJECT ENGINEER THE LATEST REVISION DATE OF THE APPROVED CONSTRUCTION PLANS.
5. ALL MATERIALS, WORKMANSHIP, AND CONSTRUCTION OF PUBLIC IMPROVEMENTS SHALL MEET OR EXCEED THE STANDARDS AND SPECIFICATIONS SET FORTH IN THE CITY OF STEAMBOAT SPRINGS TECHNICAL SPECIFICATIONS (MARCH, 2018 EDITION), THE STANDARD SPECIFICATIONS FOR ROAD AND BRIDGE CONSTRUCTION BY THE COLORADO DEPARTMENT OF TRANSPORTATION, (2019 EDITION), MOUNT WERNER WATERS 'STANDARD SPECIFICATIONS FOR WATER AND WASTEWATER UTILITIES', LATEST EDITION, AND APPLICABLE STATE AND FEDERAL REGULATIONS. WHERE THERE IS A DIRECT CONFLICT BETWEEN THESE PLANS AND THE SPECIFICATIONS, OR ANY APPLICABLE STANDARDS, THE MOST RESTRICTIVE STANDARD SHALL APPLY.
6. ALL WATER AND SANITARY SEWER CONSTRUCTION AND RELATED WORK SHALL CONFORM TO THE CITY OF STEAMBOAT SPRINGS STANDARD SPECIFICATIONS FOR WATER AND WASTEWATER UTILITIES, CURRENT EDITION.
7. ALL NECESSARY PERMITS AND APPROVALS FROM ALL APPLICABLE AGENCIES AS REQUIRED MUST BE OBTAINED IN ORDER TO PERFORM THE WORK. THIS INCLUDES, BUT IS NOT LIMITED TO, RIGHT-OF-WAY PERMIT, GRADING AND EXCAVATION PERMIT, CONSTRUCTION DEWATERING PERMIT, STORM WATER QUALITY PERMIT, ARMY CORP OF ENGINEER PERMIT, ETC. IT IS THE APPLICABLE CONTRACTOR'S RESPONSIBILITY TO OBTAIN A COPY OF ALL APPLICABLE CODES, LICENSES, SPECIFICATIONS, AND STANDARDS NECESSARY TO PERFORM THE WORK, AND BE FAMILIAR WITH THEIR CONTENTS PRIOR TO COMMENCING ANY WORK.
8. PRIOR TO ANY WORK IN THE CITY RIGHT-OF-WAY INCLUDING STREET CUTS, CONTACT THE CITY OF STEAMBOAT SPRINGS STREET DEPARTMENT AT 970.878.1807 FOR PERMIT REQUIREMENTS. NO WORK SHALL OCCUR IN THE ROW BETWEEN NOVEMBER 1 - APRIL 1 UNLESS A WRITTEN VARIANCE HAS BEEN APPROVED AND ISSUED BY THE CITY PUBLIC WORKS DIRECTOR.
9. PRIOR TO CLOSURE OF ANY STREET OR PART OF STREET, AN APPROVED OBSTRUCTION PERMIT MUST BE ISSUED BY CITY CONSTRUCTION SERVICES FOREMAN.
10. PRIOR TO START OF CONSTRUCTION A PRE-CONSTRUCTION MEETING SHALL BE SCHEDULED WITH THE APPROPRIATE CONTRACTORS, ENGINEER, SURVEYOR, TESTING COMPANY, AFFECTED AGENCIES AND KEY SUBCONTRACTORS A MINIMUM OF 48-HOURS PRIOR TO THE START OF WORK.
11. THE LOCAL ENTITY AND ENGINEER SHALL BE NOTIFIED AT LEAST 2 WORKING DAYS PRIOR TO THE START OF ANY EARTH DISTURBING ACTIVITY, OR CONSTRUCTION ON ANY AND ALL PUBLIC IMPROVEMENTS, THE LOCAL ENTITY RESERVES THE RIGHT NOT TO ACCEPT THE IMPROVEMENTS IF SUBSEQUENT TESTING REVEALS AN IMPROPER INSTALLATION.
12. COORDINATE WITH THE PROJECT ENGINEER TO IDENTIFY PROJECT INSPECTION AND TESTING REQUIREMENTS. PROVIDE FOR INSPECTIONS AND TESTING AT AN ADEQUATE FREQUENCY FOR THE PROJECT ENGINEER TO DOCUMENT THAT PROJECT IS CONSTRUCTED IN CONFORMANCE WITH THE APPROVED PLANS AND SPECIFICATIONS. PRIOR TO MAKING ANY CHANGES TO THE APPROVED PLANS, IT IS THE APPROPRIATE CONTRACTOR'S RESPONSIBILITY TO COORDINATE WITH THE PROJECT ENGINEER.
13. PROVIDE THE OWNER, ENGINEER, THEIR CONSULTANTS, INDEPENDENT TESTING LABORATORIES, ANY GOVERNMENTAL AGENCIES WITH JURISDICTIONAL INTEREST, OTHER PERSONNEL, ACCESS TO THE SITE AND THE WORK AT REASONABLE TIMES FOR THEIR OBSERVATION, INSPECTING, AND TESTING. PROVIDE THEM PROPER AND SAFE CONDITIONS FOR SUCH ACCESS AND ADVISE THEM OF THE DEVELOPER'S SITE SAFETY PROCEDURES AND PROGRAMS SO THAT THEY MAY COMPLY THEREWITH AS IS APPLICABLE. COORDINATE WITH THE PROJECT ENGINEER SO THAT INSPECTING AND TESTING ARE PROVIDED AT AN ADEQUATE FREQUENCY FOR THE PROJECT ENGINEER TO AFFIRM THAT WORK WAS COMPLETED IN SUBSTANTIAL CONFORMANCE WITH THESE APPROVED PLANS.
14. NO WORK MAY COMMENCE WITHIN ANY IMPROVED PUBLIC RIGHT-OF-WAY UNTIL A RIGHT-OF-WAY PERMIT OR APPROPRIATE CONSTRUCTION PERMIT IS OBTAINED, IF APPLICABLE. SUBMIT A CONSTRUCTION TRAFFIC CONTROL PLAN, IN ACCORDANCE WITH MUTCD, TO THE APPROPRIATE RIGHT-OF-WAY AUTHORITY, (LOCAL ENTITY, COUNTY OR STATE), FOR APPROVAL, PRIOR TO ANY CONSTRUCTION ACTIVITIES WITHIN, OR AFFECTING, THE RIGHT-OF-WAY. PROVIDE ANY AND ALL TRAFFIC CONTROL DEVICES AS MAY BE REQUIRED BY THE CONSTRUCTION ACTIVITIES.
15. SUBMIT A CONSTRUCTION SITE MANAGEMENT PLAN (CSMP) FOR REVIEW AND APPROVAL BY THE CITY CONSTRUCTION SERVICES FOREMAN PRIOR TO START OF CONSTRUCTION. THE CSMP MUST BE MAINTAINED ON-SITE AND UPDATED AS NEEDED TO REFLECT CURRENT CONDITIONS.
16. ALL CONTRACTORS ARE SPECIFICALLY CAUTIONED THAT THE LOCATION AND/OR ELEVATION OF EXISTING UTILITIES, AS SHOWN ON THESE PLANS, IS BASED ON RECORDS OF THE VARIOUS UTILITY COMPANIES AND, WHERE POSSIBLE, MEASUREMENTS TAKEN IN THE FIELD. THE INFORMATION IS NOT TO BE RELIED UPON AS BEING EXACT OR COMPLETE. CONTACT THE UTILITY NOTIFICATION CENTER OF COLORADO (UNCC) AT 1-800-922-1987, AT LEAST 2 WORKING DAYS PRIOR TO BEGINNING EXCAVATION OR GRADING, TO HAVE ALL REGISTERED UTILITY LOCATIONS MARKED. OTHER UNREGISTERED UTILITY ENTITIES (I.E. DITCH / IRRIGATION COMPANY) ARE TO BE LOCATED BY CONTACTING THE RESPECTIVE REPRESENTATIVE. UTILITY SERVICE LATERALS ARE ALSO TO BE LOCATED PRIOR TO BEGINNING EXCAVATION OR GRADING. THE TYPE, SIZE, LOCATION AND NUMBER OF ALL KNOWN UNDERGROUND UTILITIES ARE APPROXIMATE WHEN SHOWN ON THE DRAWINGS. VERIFY THE EXISTENCE AND LOCATION OF ALL UNDERGROUND UTILITIES ALONG THE ROUTE OF THE WORK BEFORE COMMENCING NEW CONSTRUCTION. THE CONTRACTOR SHALL NOTIFY THE ENGINEER OF ALL EXISTING UTILITIES THAT CONFLICT WITH THE PROPOSED IMPROVEMENTS SHOWN ON THESE PLANS.
17. FIELD LOCATE AND VERIFY ELEVATIONS OF ALL EXISTING SEWER MAINS, WATER MAINS, CURBS, GUTTERS AND OTHER UTILITIES AT THE POINTS OF CONNECTION SHOWN ON THE PLANS, AND AT ANY UTILITY CROSSINGS PRIOR TO INSTALLING ANY OF THE NEW IMPROVEMENTS. IF A CONFLICT EXISTS AND/OR A DESIGN MODIFICATION IS REQUIRED, COORDINATE WITH THE ENGINEER TO MODIFY THE DESIGN. DESIGN MODIFICATION(S) MUST BE APPROVED BY THE LOCAL ENTITY PRIOR TO BEGINNING CONSTRUCTION.
18. ALL UTILITY INSTALLATIONS WITHIN OR ACROSS THE ROADBED OR OTHER PAVED AREAS MUST BE COMPLETED PRIOR TO THE FINAL STAGES OF ROAD CONSTRUCTION. FOR THE PURPOSES OF THESE STANDARDS, ANY WORK INCLUDING, GRAVELS, PAVEMENTS, CURB AND GUTTER ABOVE THE SUBGRADE IS CONSIDERED FINAL. STAGE WORK. ALL SERVICE LINES MUST BE STUBBED BEYOND THE ROAD PLATFORM OR TO THE PROPERTY LINES AND MARKED SO AS TO REDUCE THE EXCAVATION NECESSARY FOR BUILDING CONNECTIONS.
19. COORDINATE AND COOPERATE WITH THE LOCAL ENTITY, AND ALL UTILITY COMPANIES INVOLVED, WITH REGARD TO RELOCATIONS, ADJUSTMENTS, EXTENSIONS AND REARRANGEMENTS OF EXISTING UTILITIES DURING CONSTRUCTION, AND TO ASSURE THAT THE WORK IS ACCOMPLISHED IN A TIMELY FASHION AND WITH A MINIMUM DISRUPTION OF SERVICE. CONTACT, IN ADVANCE, ALL PARTIES AFFECTED BY ANY DISRUPTION OF ANY UTILITY SERVICE AS WELL AS THE UTILITY COMPANIES.
20. NO WORK MAY COMMENCE WITHIN ANY PUBLIC STORM WATER, SANITARY SEWER OR POTABLE WATER SYSTEM UNTIL THE UTILITY PROVIDERS ARE NOTIFIED. NOTIFICATION SHALL BE A MINIMUM OF TWO (2) WORKING DAYS PRIOR TO COMMENCEMENT OF ANY WORK, AT THE DISCRETION OF THE WATER UTILITY PROVIDER. A PRE-CONSTRUCTION MEETING MAY BE REQUIRED PRIOR TO COMMENCEMENT OF ANY WORK.
21. PROTECT ALL UTILITIES DURING CONSTRUCTION AND FOR COORDINATE WITH THE APPROPRIATE UTILITY COMPANY FOR ANY UTILITY CROSSINGS REQUIRED.
22. WHEN APPLICABLE, THE DEVELOPER AND/OR CONTRACTOR SHALL HAVE ON-SITE AT ALL TIMES, EACH OF THE FOLLOWING:
- BEST MANAGEMENT PRACTICES (BMP) MAINTENANCE FOLDER
- UP TO DATE STORMWATER MANAGEMENT PLAN (SWMP) THAT ACCURATELY REPRESENTS CURRENT FIELD CONDITIONS
- ONE (1) SIGNED COPY OF THE APPROVED PLANS
- ONE (1) COPY OF THE APPROPRIATE STANDARDS AND SPECIFICATIONS
- A COPY OF ANY PERMITS AND EXTENSION AGREEMENTS NEEDED FOR THE JOB.
23. IF, DURING THE CONSTRUCTION PROCESS, CONDITIONS ARE ENCOUNTERED WHICH COULD INDICATE A SITUATION THAT IS NOT IDENTIFIED IN THE PLANS OR SPECIFICATIONS, CONTACT THE DESIGNER AND THE LOCAL ENTITY ENGINEER IMMEDIATELY.
24. ALL REFERENCES TO ANY PUBLISHED STANDARDS SHALL REFER TO THE LATEST REVISION OF SAID STANDARD, UNLESS SPECIFICALLY STATED OTHERWISE.
25. PROVIDE ALL LABOR AND MATERIALS NECESSARY FOR THE COMPLETION OF THE INTENDED IMPROVEMENTS SHOWN ON THESE DRAWINGS, OR DESIGNATED TO BE PROVIDED, INSTALLED, OR CONSTRUCTED, UNLESS SPECIFICALLY NOTED OTHERWISE.
26. THE CONTRACTOR SHALL BE RESPONSIBLE FOR RECORDING AS-BUILT INFORMATION ON A SET OF RECORD DRAWINGS KEPT ON THE CONSTRUCTION SITE, AND AVAILABLE TO THE LOCAL ENTITY'S INSPECTOR AT ALL TIMES.
27. DIMENSIONS FOR LAYOUT AND CONSTRUCTION ARE NOT TO BE SCALED FROM ANY DRAWING. IF PERTINENT DIMENSIONS OR ELEVATIONS ARE NOT SHOWN, CONTACT THE DESIGNER FOR CLARIFICATION, AND ANNOTATE THE PROVIDED DIMENSION ON THE AS-BUILT RECORD DRAWINGS. CONTOURS ARE NOT SUITABLE FOR CONSTRUCTION LAYOUT.
28. SEQUENCE INSTALLATION OF UTILITIES IN SUCH A MANNER AS TO MINIMIZE POTENTIAL UTILITY CONFLICTS. IN GENERAL, GRADE RESTRICTED UTILITIES SUCH AS STORM SEWER AND SANITARY SEWER, SHOULD BE CONSTRUCTED PRIOR TO INSTALLATION OF THE WATER LINES AND DRY UTILITIES.
29. EXISTING FENCES, TREES, STREETS, SIDEWALKS, CURBS AND GUTTERS, LANDSCAPING, STRUCTURES, AND IMPROVEMENTS DESTROYED, DAMAGED OR REMOVED DUE TO CONSTRUCTION OF THIS PROJECT SHALL BE REPLACED OR RESTORED IN LIKE KIND AT THE CONTRACTOR'S EXPENSE, UNLESS OTHERWISE INDICATED ON THESE PLANS.
30. THESE CONSTRUCTION PLANS SHALL BE VALID FOR A PERIOD OF THREE YEARS FROM THE DATE OF APPROVAL BY THE A.H.J. USE OF THESE PLANS AFTER THE EXPIRATION DATE WILL REQUIRE A NEW REVIEW AND APPROVAL PROCESS BY THE LOCAL ENTITY PRIOR TO COMMENCEMENT OF ANY WORK SHOWN IN THESE PLANS.
31. ALL CONSTRUCTION IN AREAS DESIGNATED AS WILD FIRE HAZARD AREAS SHALL BE DONE IN ACCORDANCE WITH THE CONSTRUCTION CRITERIA AS ESTABLISHED IN THE WILD FIRE HAZARD AREA MITIGATION REGULATIONS IN FORCE AT THE TIME OF CONSTRUCTION.
32. THE CONTRACTOR AGREES THAT BY COMMENCING CONSTRUCTION THAT HE SHALL ASSUME SOLE AND COMPLETE RESPONSIBILITY FOR JOB SITE CONDITIONS DURING THE CONSTRUCTION OF THE PROJECT, INCLUDING, BUT NOT LIMITED TO THE SAFETY OF ALL PERSONS AND PROPERTY; THAT THIS REQUIREMENT SHALL APPLY CONTINUOUSLY AND NOT BE LIMITED TO NORMAL WORKING HOURS; AND THAT THE CONTRACTOR SHALL BE RESPONSIBLE AND HOLD THE LOCAL ENTITY AND THE GOVERNING AGENCIES AND THE OFFICERS, DIRECTORS, PARTNERS, EMPLOYEES, AGENTS AND OTHER CONSULTANTS OF EACH AND ANY OF THEM HARMLESS FROM ANY AND ALL LIABILITY, REAL OR ALLEGED, IN CONNECTION WITH THE PERFORMANCE OF WORK ON THIS PROJECT, EXCEPT FOR LIABILITY ARISING FROM THE NEGLIGENCE OF THE OWNER, THE ENGINEER, OR THE GOVERNING AGENCIES.
33. NOTIFY THE ENGINEER IMMEDIATELY UPON DISCOVERING ANY CONFLICTS OR OTHER PROBLEMS IN CONFORMING TO THE APPROVED

- CONSTRUCTION DRAWINGS, SPECIFICATIONS OR DETAILS FOR ANY ELEMENT OF THE PROPOSED IMPROVEMENTS PRIOR TO PROCEEDING WITH ITS CONSTRUCTION.
35. COORDINATE THE INSTALLATION OR RELOCATION OF THE DRY UTILITY COMPANY'S FACILITIES. COST OF THE DRY UTILITY WORK SHALL BE BORNE BY THE OWNER, EXCEPT AS INDICATED IN THE PLANS AND SPECIFICATIONS.
36. PRESERVE PRIVATE AND PUBLIC PROPERTY AND PROTECT IT FROM DAMAGE THAT MAY RESULT FROM CONSTRUCTING THESE PROPOSED IMPROVEMENTS.
37. ACCESS TO ALL ADJACENT PROPERTIES AND FACILITIES SHALL BE MAINTAINED AT ALL TIMES. REQUIRED INTERRUPTION OF ACCESS SHALL BE COORDINATED WITH THE PROPERTY AND PROJECT OWNERS.
38. IF HAZARDOUS MATERIAL OR SUSPECT MATERIAL IS ENCOUNTERED NOTIFY THE OWNER AND ENGINEER BEFORE CONTINUING WORK. HAZARDOUS MATERIALS SHALL BE REMOVED AS REQUIRED.
39. THE APPROPRIATE CONTRACTOR SHALL BE RESPONSIBLE FOR THE SOURCE OF CONSTRUCTION WATER FOR USE ON THIS PROJECT.
40. EXCESS MATERIAL SHALL BE REMOVED FROM SITE AND HANDLED IN ACCORDANCE TO ALL RULES AND REQUIREMENTS. A SEPARATE PERMIT MAY BE REQUIRED AND SHALL BE COORDINATED WITH THE AUTHORITY HAVING JURISDICTION.
41. OFFSITE AND ADJACENT SITE DATA IS FOR REFERENCE PURPOSES ONLY.
42. ALL LANDSCAPING, REVEGETATION AND WETLANDS REQUIREMENTS BY OTHERS. ALL DISTURBED AREAS ARE TO BE REVEGETATED UNLESS OTHERWISE NOTED.
43. ENSURE THAT WORK FOR THIS PROJECT BE PERFORMED BY CONTRACTORS (INCLUDING CONTRACTOR'S EMPLOYEES AND AGENTS) POSSESSING THE SKILLS, EXPERTISE AND UNDERSTANDING OF ALL APPLICABLE CODES, SPECIFICATIONS, STANDARDS AND MANUFACTURER REQUIREMENTS. BY COMMENCING WORK, THE CONTRACTORS REPRESENT THAT THEY UNDERSTAND AND ACCEPT THIS REQUIREMENT.
44. ALL CONSTRUCTION ACTIVITIES AND DISTURBANCES SHALL OCCUR WITHIN THE PROPERTY LIMITS. WHERE OFF-SITE WORK IS APPROVED, WRITTEN PERMISSION OF THE ADJACENT PROPERTY OWNER MUST BE OBTAINED PRIOR TO ANY OFF-SITE GRADING OR CONSTRUCTION.

CONSTRUCTION NOTES

A. GRADING AND DRAINAGE

- 45. NO WORK SHALL OCCUR IN WETLANDS OR FLOODPLAINS WITHOUT PERMITS. ANY WORK SHALL BE IN ACCORDANCE WITH ISSUED PERMITS.
46. VEGETATED SLOPES GREATER THAN 3:1 REQUIRE SOIL STABILIZATION.
47. CLEAN ALL INSTALLED CULVERTS AND STORM SEWERS PRIOR TO SUBSTANTIAL COMPLETION INSPECTIONS.
48. LENGTHS SHOWN ON PLANS ARE HORIZONTAL LENGTHS FROM CENTER OF MANHOLE TO CENTER OF MANHOLE OR TO THE END OF THE FLARED END SECTIONS. ACTUAL LENGTHS MAY VARY.
49. SLOPES ARE CALCULATED FROM INSIDE EDGE OF MANHOLE/STRUCTURE TO INSIDE EDGE OF MANHOLE/STRUCTURE.
50. IMPERVIOUS CLAY DAMS ARE REQUIRED IN TRENCH AT 50-FT INTERVALS AND AT CHANGES IN PIPE DIRECTION AND/OR AT PIPE JUNCTIONS FOR ALL DRAINAGE STRUCTURES.
51. MINIMUM RECOMMENDATIONS (TO BE CONFIRMED OR REPLACED BY GEOTECHNICAL ENGINEER); PROPOSED FILL AREAS WHERE PAVEMENT OR SITE CONCRETE IS ANTICIPATED SHOULD BE PREPARED BY STRIPPING EXISTING TOPSOIL AND ORGANIC MATERIALS, SCARIFICATION TO A DEPTH OF AT LEAST 8 INCHES AND COMPACTION TO MINIMUM VALUES GIVEN BELOW. MOISTURE CONDITIONING MAY BE REQUIRED TO ATTAIN STABILITY AND MINIMUM COMPACTION.

SITE FILLS AND TRENCH BACKFILL SHOULD CONSIST OF APPROVED ON-SITE OR IMPORTED MATERIALS. FILLS SHOULD BE UNIFORMLY PLACED AND COMPACTED IN 6 TO 8 INCH LOOSE LIFTS TO AT LEAST 98 PERCENT OF THE MAXIMUM STANDARD PROCTOR DENSITY AND WITHIN 2 PERCENT OF THE OPTIMUM MOISTURE CONTENT (ASTM D998). MOISTURE CONDITIONING OF FILL MATERIALS MAY BE REQUIRED TO ATTAIN MINIMUM COMPACTION AND STABILITY REQUIREMENTS.
52. A GEOTECHNICAL REPORT FOR THIS PROJECT WAS PREPARED UNDER THE TITLE OF "SUPPLEMENTAL SUBSURFACE INVESTIGATION AND GEOTECHNICAL RECOMMENDATIONS, STEAMBOAT BASECAMP, LOTS 1 AND 2, WORLDWEST SUBDIVISION, STEAMBOAT SPRINGS, COLORADO" BY MWCC DATED "MARCH 15, 2021" AND THEIR RECOMMENDATIONS ARE HEREBY INCORPORATED HEREIN. IF A CONFLICT OR DISCREPANCY OCCURS, NOTIFY THE ENGINEER IMMEDIATELY UPON DISCOVERY.

B. EROSION CONTROL

- 53. SUBMIT A CONSTRUCTION SITE MANAGEMENT PLAN TO THE CITY FOR APPROVAL PRIOR TO BUILDING PERMIT ISSUANCE.
54. WORK IN A MANNER THAT MINIMIZES THE POTENTIAL FOR EROSION.
55. INSTALL, INSPECT AND MAINTAIN ALL NECESSARY EROSION AND SEDIMENT CONTROL DURING CONSTRUCTION AND REMOVE EROSION CONTROL WHEN PROJECT IS COMPLETE AND VEGETATION IS ESTABLISHED. WHEN TEMPORARY EROSION CONTROL MEASURES ARE REMOVED, CLEAN UP AND REMOVE ALL SEDIMENT AND DEBRIS FROM ALL DRAINAGE INFRASTRUCTURE AND OTHER PUBLIC FACILITIES.
56. ANY AREA DISTURBED BY CONSTRUCTION AND NOT PAVED OR NATURAL ROCK SURFACES SHALL BE REVEGETATED WITHIN ONE CONSTRUCTION SEASON.
57. ALL REQUIRED PERIMETER SILT AND CONSTRUCTION FENCING SHALL BE INSTALLED PRIOR TO ANY LAND DISTURBING ACTIVITY (STOCKPILING, STRIPPING, GRADING, ETC.). ALL OTHER REQUIRED EROSION CONTROL MEASURES SHALL BE INSTALLED AT THE APPROPRIATE TIME IN THE CONSTRUCTION SEQUENCE AS INDICATED IN THE APPROVED PROJECT SCHEDULE, CONSTRUCTION PLANS, AND STORMWATER MANAGEMENT PLAN.
58. AT ALL TIMES DURING CONSTRUCTION, FOR PREVENT AND CONTROL ON-SITE EROSION INCLUDING KEEPING THE PROPERTY SUFFICIENTLY WATERED SO AS TO MINIMIZE WIND BLOWN SEDIMENT. INSTALL AND MAINTAIN ALL EROSION CONTROL FACILITIES SHOWN HEREIN.
59. ENSURE THAT NO MUD OR DEBRIS SHALL BE TRACKED ONTO THE EXISTING PUBLIC STREET SYSTEM. MUD AND DEBRIS MUST BE REMOVED BY THE END OF EACH WORKING DAY BY AN APPROPRIATE MECHANICAL METHOD (I.E. MACHINE BROOM SWEEP, LIGHT DUTY FRONT-END LOADER, ETC.) OR AS APPROVED BY THE LOCAL ENTITY STREET INSPECTOR.
60. ALL STRUCTURAL EROSION CONTROL MEASURES SHALL BE INSTALLED AT THE LIMITS OF CONSTRUCTION AND AT AREAS WITH DISTURBED SOIL, ON- OR OFF-SITE, PRIOR TO ANY OTHER GROUND-DISTURBING ACTIVITY. ALL EROSION CONTROL MEASURES SHALL BE MAINTAINED IN GOOD REPAIR, UNTIL SUCH TIME AS THE ENTIRE DISTURBED AREA IS STABILIZED WITH HARD SURFACE OR LANDSCAPING. TO MITIGATE EROSION, UTILIZE STANDARD EROSION CONTROL TECHNIQUES DESCRIBED IN THE URBAN STORM DRAINAGE CRITERIA MANUAL, VOLUME 3 - BEST MANAGEMENT PRACTICES, AS PUBLISHED BY THE URBAN DRAINAGE AND FLOOD CONTROL DISTRICT (UDFCO).
61. PRE-DISTURBANCE VEGETATION SHALL BE PROTECTED AND RETAINED WHEREVER POSSIBLE. REMOVAL OR DISTURBANCE OF EXISTING VEGETATION SHALL BE LIMITED TO THE AREA(S) REQUIRED FOR IMMEDIATE CONSTRUCTION OPERATIONS, AND FOR THE SHORTEST PRACTICAL PERIOD OF TIME.
62. ALL SOILS EXPOSED DURING LAND DISTURBING ACTIVITY (STRIPPING, GRADING, UTILITY INSTALLATIONS, STOCKPILING, FILLING, ETC.) SHALL BE KEPT IN A ROUGHENED CONDITION BY RIPPING OR DISKING ALONG LAND CONTOURS UNTIL MULCH, VEGETATION, OR OTHER PERMANENT EROSION CONTROL BMPs ARE INSTALLED. NO SOILS IN AREAS OUTSIDE PROJECT STREET RIGHTS-OF-WAY SHALL REMAIN EXPOSED BY LAND DISTURBING ACTIVITY FOR MORE THAN THIRTY (30) DAYS BEFORE REQUIRED TEMPORARY OR PERMANENT EROSION CONTROL (E.G. SEED/MULCH, LANDSCAPING, ETC.) IS INSTALLED, UNLESS OTHERWISE APPROVED BY THE TOWN/COUNTY.
63. IN ORDER TO MINIMIZE EROSION POTENTIAL, ALL TEMPORARY (STRUCTURAL) EROSION CONTROL MEASURES SHALL:
a. BE INSPECTED AT A MINIMUM OF ONCE EVERY TWO (2) WEEKS AND AFTER EACH SIGNIFICANT STORM EVENT AND REPAIRED OR RECONSTRUCTED AS NECESSARY IN ORDER TO ENSURE THE CONTINUED PERFORMANCE OF THEIR INTENDED FUNCTION.
b. REMAIN IN PLACE UNTIL SUCH TIME AS ALL THE SURROUNDING DISTURBED AREAS ARE SUFFICIENTLY STABILIZED AS DETERMINED BY THE EROSION CONTROL INSPECTOR.
c. BE REMOVED AFTER THE SITE HAS BEEN SUFFICIENTLY STABILIZED AS DETERMINED BY THE EROSION CONTROL INSPECTOR.
64. IMMEDIATELY CLEAN UP ANY CONSTRUCTION MATERIALS INADVERTENTLY DEPOSITED ON EXISTING STREETS, SIDEWALKS, OR OTHER PUBLIC RIGHTS OF WAY, AND MAKE SURE STREETS AND WALKWAYS ARE CLEANED AT THE END OF EACH WORKING DAY.
65. ALL RETAINED SEDIMENTS, PARTICULARLY THOSE ON PAVED ROADWAY SURFACES, SHALL BE REMOVED AND DISPOSED OF IN A MANNER AND LOCATION SO AS NOT TO CAUSE THEIR RELEASE INTO ANY WATERS OF THE UNITED STATES.
66. NO SOIL STOCKPILE SHALL EXCEED TEN (10) FEET IN HEIGHT. ALL SOIL STOCKPILES SHALL BE PROTECTED FROM SEDIMENT TRANSPORT BY SURFACE ROUGHENING, WATERING, AND PERIMETER SILT FENCING. ANY SOIL STOCKPILE REMAINING AFTER THIRTY (30) DAYS SHALL BE SEEDED AND MULCHED.
67. THE STORMWATER VOLUME CAPACITY OF DETENTION PONDS WILL BE RESTORED AND STORM SEWER LINES WILL BE CLEANED UPON COMPLETION OF THE PROJECT.
68. THE COLORADO DISCHARGE PERMIT SYSTEM (CDPS) REQUIREMENTS MAKE IT UNLAWFUL TO DISCHARGE OR ALLOW THE DISCHARGE OF ANY POLLUTANT OR CONTAMINATED WATER FROM CONSTRUCTION SITES. POLLUTANTS INCLUDE, BUT ARE NOT LIMITED TO DISCARDED BUILDING MATERIALS, CONCRETE TRUCK WASHOUT MATERIALS, OIL AND GAS PRODUCTS, LITTER, AND SANITARY WASTE. TAKE WHATEVER MEASURES ARE NECESSARY TO ASSURE THE PROPER CONTAINMENT AND DISPOSAL OF POLLUTANTS ON THE SITE IN ACCORDANCE WITH ANY AND ALL APPLICABLE LOCAL, STATE, AND FEDERAL REGULATIONS.

- 72. A DESIGNATED AREA SHALL BE PROVIDED ON SITE FOR CONCRETE TRUCK CHUTE WASHOUT. THE AREA SHALL BE CONSTRUCTED SO AS TO CONTAIN WASHOUT MATERIAL AND LOCATED AT LEAST FIFTY (50) FEET AWAY FROM ANY WATERWAY DURING CONSTRUCTION. UPON COMPLETION OF CONSTRUCTION ACTIVITIES THE CONCRETE WASHOUT MATERIAL WILL BE REMOVED AND PROPERLY DISPOSED OF PRIOR TO THE AREA BEING RESTORED.
73. THE DRAINAGE REPORT SHALL BE REFERENCED WHEN PREPARING THE PROJECT'S STORMWATER MANAGEMENT PLAN. A DRAINAGE REPORT FOR THIS PROJECT WAS COMPLETED BY LANDMARK CONSULTANTS TITLED "TBD" AND IS DATED "TBD".

C. PAVING

- 74. PAVING OF PUBLIC STREETS SHALL NOT START UNTIL SUBGRADE COMPACTION AND MATERIAL TESTS ARE TAKEN AND ACCEPTED BY THE PUBLIC WORKS DIRECTOR.
75. EXISTING ASPHALT PAVEMENT SHALL BE STRAIGHT SAW CUT A MINIMUM DISTANCE OF 12 INCHES FROM THE EXISTING EDGE. TO CREATE A CLEAN CONSTRUCTION JOINT, REMOVE EXISTING PAVEMENT TO A DISTANCE WHERE A CLEAN CONSTRUCTION JOINT CAN BE MADE. TACK COAT SHALL BE APPLIED TO ALL EXPOSED SURFACES INCLUDING SAW CUTS, POTHOLES, TRENCHES, AND ASPHALT OVERLAY. ASPHALT PATCHES IN THE RIGHT-OF-WAY SHALL BE PER CITY SPECIFICATIONS.
76. CONTACT CITY STREETS SUPERINTENDENT AT (970) 879-1807 TO SCHEDULE INSTALLATION OF PUBLIC STREET SIGNS. ALL OTHER TRAFFIC CONTROL SIGNS ARE THE RESPONSIBILITY OF THE DEVELOPER.
77. NO BASE MATERIAL SHALL BE LAID UNTIL THE SUBGRADE HAS BEEN INSPECTED AND APPROVED BY THE ENGINEER.
78. VALVE BOXES, CLEANOUTS AND MANHOLES ARE TO BE BROUGHT UP TO GRADE AT THE TIME OF PAVEMENT PLACEMENT OR OVERLAY. VALVE BOX ADJUSTING RINGS ARE NOT ALLOWED.
79. WHEN AN EXISTING ASPHALT STREET MUST BE CUT, THE STREET MUST BE RESTORED TO A CONDITION EQUAL TO OR BETTER THAN ITS ORIGINAL CONDITION. THE EXISTING STREET CONDITION SHALL BE DOCUMENTED BY THE ENGINEER BEFORE ANY CUTS ARE MADE. THE FINISHED PATCH SHALL BLEND SMOOTHLY INTO THE EXISTING SURFACE.
80. PERFORM A GUTTER WATER FLOW TEST IN THE PRESENCE OF THE ENGINEER AND PRIOR TO INSTALLATION OF ASPHALT. GUTTERS THAT HOLD MORE THAN 1/4 INCH DEEP OR 5 FEET LONGITUDINALLY, OF WATER, SHALL BE COMPLETELY REMOVED AND RECONSTRUCTED TO DRAIN PROPERLY.
81. PRIOR TO PLACEMENT OF H.B.P. OR CONCRETE WITHIN THE STREET AND AFTER MOISTURE/DENSITY TESTS HAVE BEEN TAKEN ON THE SUBGRADE MATERIAL (WHEN A FULL DEPTH SECTION IS PROPOSED) OR ON THE SUBGRADE AND BASE MATERIAL (WHEN A COMPOSITE SECTION IS PROPOSED), A MECHANICAL "PROOF ROLL" WILL BE REQUIRED. THE ENTIRE SUBGRADE AND/OR BASE MATERIAL SHALL BE ROLLED WITH A HEAVILY LOADED VEHICLE HAVING A TOTAL GW OF NOT LESS THAN 50,000 LBS. AND A SINGLE AXLE WEIGHT OF AT LEAST 18,000 LBS. WITH PNEUMATIC TIRES INFLATED TO NOT LESS THAN 90 P.S.I.G. "PROOF ROLL" VEHICLES SHALL NOT TRAVEL AT SPEEDS GREATER THAN 3 M.P.H. ANY PORTION OF THE SUBGRADE OR BASE MATERIAL WHICH EXHIBITS EXCESSIVE PUMPING OR DEFORMATION, AS DETERMINED BY THE ENGINEER, SHALL BE REWORKED, REPLACED OR OTHERWISE MODIFIED TO FORM A SMOOTH, NON-YIELDING SURFACE. THE ENGINEER SHALL BE NOTIFIED AT LEAST 24 HOURS PRIOR TO THE "PROOF ROLL." ALL "PROOF ROLLS" SHALL BE PERFORMED IN THE PRESENCE OF AN ENGINEER.
82. NO UNDERMINING OF EXISTING PAVEMENT SHALL BE ALLOWED. IF UNDERMINING IS EVIDENT, PAVEMENT SHALL BE CUT BACK ACCORDINGLY. NO ADDITIONAL PAYMENT SHALL BE PROVIDED.
83. ALL WATER AND SEWER CONSTRUCTION SHALL BE PER CITY OF STEAMBOAT SPRINGS UTILITY STANDARD SPECIFICATIONS, LATEST EDITION, AS APPLICABLE.
84. MAINTAIN 10" HORIZONTAL AND 18" VERTICAL MINIMUM SEPARATION BETWEEN ALL SANITARY SEWER MAINS, WATER MAINS & SERVICES.
85. MANHOLES LOCATED OUTSIDE OF THE ROADWAY SHALL PROTRUDE 1' ABOVE EXISTING GRADE TO REDUCE INFILTRATION. GRADE SURFACE TO DRAIN AROUND/ADJAWY FROM MANHOLE RIMS.
86. ALL MANHOLES LOCATED IN THE ROADWAY SHALL HAVE RIM ELEVATIONS ADJUSTED TO 1" BELOW FINISHED GRADE. IF NECESSARY, CONE SECTIONS SHALL BE ROTATED TO PREVENT LIDS BEING LOCATED WITHIN VEHICLE OR BICYCLE WHEEL PATHS.
87. SEWER SERVICE SHALL HAVE A MINIMUM OF 4-FT OF COVER.
88. WATER SERVICE SHALL HAVE A MINIMUM OF 7-FT OF COVER.
89. ALL WATER PIPE SHALL BE INSTALLED WITH A #10 SOLID COPPER WIRE COATED WITH 45 MIL POLYETHYLENE FOR LOCATING PURPOSES. "GLEN TEST STATIONS" BY VALVCO, INC TRACER WIRE TEST STATIONS SHALL BE INSTALLED ADJACENT TO ALL FIRE HYDRANTS. ADDITIONAL LOCATIONS MAY BE REQUIRED.
90. THE PARTICLE SIZE OF BEDDING AND SHADING MATERIAL SHALL BE 3/8 INCH WASHED OR SCREENED ROCK (NOT ROAD BASE OR CLASS 6) AND SHALL EXTEND THE FULL WIDTH OF THE TRENCH.
91. ALL MATERIALS USED FOR BACKFILL SHALL BE FREE FROM REFUSE ORGANIC MATERIAL, COBBLES, BOULDERS, LARGE ROCKS OR STONES OR FROZEN SOLIDS GREATER THAN 6 INCHES IN DIAMETER.
92. ALL TRENCHES SHALL BE COMPACTED TO 95% AS DETERMINED BY ASTM D698 (STANDARD PROCTOR) OR AS SPECIFIED BY GEOTECHNICAL ENGINEER.

PROJECT NOTES:

- 93. AN AUTOCAD COMPATIBLE FILE WILL BE PROVIDED FOR CONSTRUCTION STAKING PURPOSES, UPON ACCEPTANCE OF LANDMARK'S CAD RELEASE POLICY.
94. IF THESE DRAWINGS ARE PRESENTED IN A FORMAT OTHER THAN 24" X 36", THE GRAPHIC SCALE SHOULD NOT BE USED.
95. THE CONTRACTOR ACKNOWLEDGES AND UNDERSTANDS THAT THE CONTRACT DOCUMENTS MAY REPRESENT IMPERFECT DATA AND MAY CONTAIN ERRORS, OMISSIONS, CONFLICTS, INCONSISTENCIES, CODE VIOLATIONS AND IMPROPER USE OF MATERIALS. SUCH DEFICIENCIES WILL BE CORRECTED WHEN IDENTIFIED. THE CONTRACTOR AGREES TO CAREFULLY STUDY AND COMPARE THE INDIVIDUAL CONTRACT DOCUMENTS AND REPORT AT ONCE IN WRITING TO THE OWNER ANY DEFICIENCIES THE CONTRACTOR MAY DISCOVER. THE CONTRACTOR FURTHER AGREES TO REQUIRE EACH SUBCONTRACTOR TO LIKEWISE STUDY THE DOCUMENTS AND REPORT AT ONCE ANY DEFICIENCIES DISCOVERED.
96. THE CONTRACTOR SHALL RESOLVE ALL REPORTED APPLICABLE DEFICIENCIES WITH LANDMARK PRIOR TO AWARDED ANY SUBCONTRACTS OR STARTING ANY WORK WITH THE CONTRACTOR'S OWN EMPLOYEES. IF ANY DEFICIENCIES CANNOT BE RESOLVED BY THE CONTRACTOR WITHOUT ADDITIONAL TIME OR ADDITIONAL EXPENSES, THE CONTRACTOR SHALL SO INFORM THE OWNER IN WRITING. ANY SUCH ADDITIONAL WORK PERFORMED PRIOR TO RECEIPT OF INSTRUCTIONS FROM THE OWNER WILL BE DONE AT THE CONTRACTOR'S RISK.

CONSTRUCTION PHASE SERVICES:

IT IS UNDERSTOOD AND AGREED THAT LANDMARK DOES NOT HAVE AN OBLIGATION TO CONDUCT CONSTRUCTION OBSERVATION OR REVIEW OF THE CONTRACTOR'S PERFORMANCE OR ANY OTHER CONSTRUCTION PHASE SERVICES, AND THAT SUCH SERVICES WILL BE PROVIDED FOR BY THE OWNER. THE OWNER ASSUMES ALL RESPONSIBILITY FOR INTERPRETATION OF THESE CONSTRUCTION DOCUMENTS AND FOR CONSTRUCTION OBSERVATION AND THE OWNER WAIVES ANY CLAIMS AGAINST LANDMARK THAT MAY BE IN ANY WAY CONNECTED THERETO.
IN ADDITION, THE OWNER AGREES, TO THE FULLEST EXTENT PERMITTED BY LAW, TO INDEMNIFY AND HOLD HARMLESS LANDMARK, ITS OFFICERS, DIRECTORS, EMPLOYEES AND SUBCONTRACTORS COLLECTIVELY, LANDMARK AGAINST ALL DAMAGES, LIABILITIES OR COSTS, INCLUDING REASONABLE ATTORNEY'S FEES AND DEFENSE COSTS, ARISING OUT OF OR IN ANY WAY CONNECTED WITH THE PERFORMANCE OF SUCH SERVICES BY OTHER PERSONS OR ENTITIES AND FROM ANY AND ALL CLAIMS ARISING FROM MODIFICATIONS, CLARIFICATIONS, INTERPRETATIONS, ADJUSTMENTS OR CHANGES MADE TO THESE CONSTRUCTION DOCUMENTS TO REFLECT CHANGED FIELD OR OTHER CONDITIONS, EXCEPT FOR CLAIMS ARISING FROM THE SOLE NEGLIGENCE OR WILLFUL MISCONDUCT OF LANDMARK.

Table with 3 columns: ABBREVIATIONS, DESCRIPTION, and BY: DATE. Lists various construction terms and their corresponding abbreviations.

Table with 3 columns: PROJECT, DATE, and CONTRACT. Contains project details: PROJECT: 2387-04, DATE: 1-28-22, CONTRACT: Gfp.

Table with 3 columns: NO, DATE, BY. A grid for tracking changes or approvals.

Table with 3 columns: NO, DATE, BY. A grid for tracking changes or approvals.

Table with 3 columns: NO, DATE, BY. A grid for tracking changes or approvals.

Table with 3 columns: NO, DATE, BY. A grid for tracking changes or approvals.

Table with 3 columns: NO, DATE, BY. A grid for tracking changes or approvals.

CALL UTILITY NOTIFICATION CENTER OF COLORADO
811
Know what's below. Call before you dig.
CALL 2 BUSINESS DAYS IN ADVANCE BEFORE YOU DIG, GRADE, OR EXCAVATE FOR THE MARKING OF UNDERGROUND MEMBER UTILITIES.

NOT VALID WITHOUT ORIGINAL SIGNATURE AND DATE

Vertical sidebar containing: CIVIL ENGINEERS | SURVEYORS, LANDMARK CONSULTANTS, INC. logo, Steamboat Basecamp - Phase I, Notes, SHEET C.002, and contact information for Landmark-CO.com.

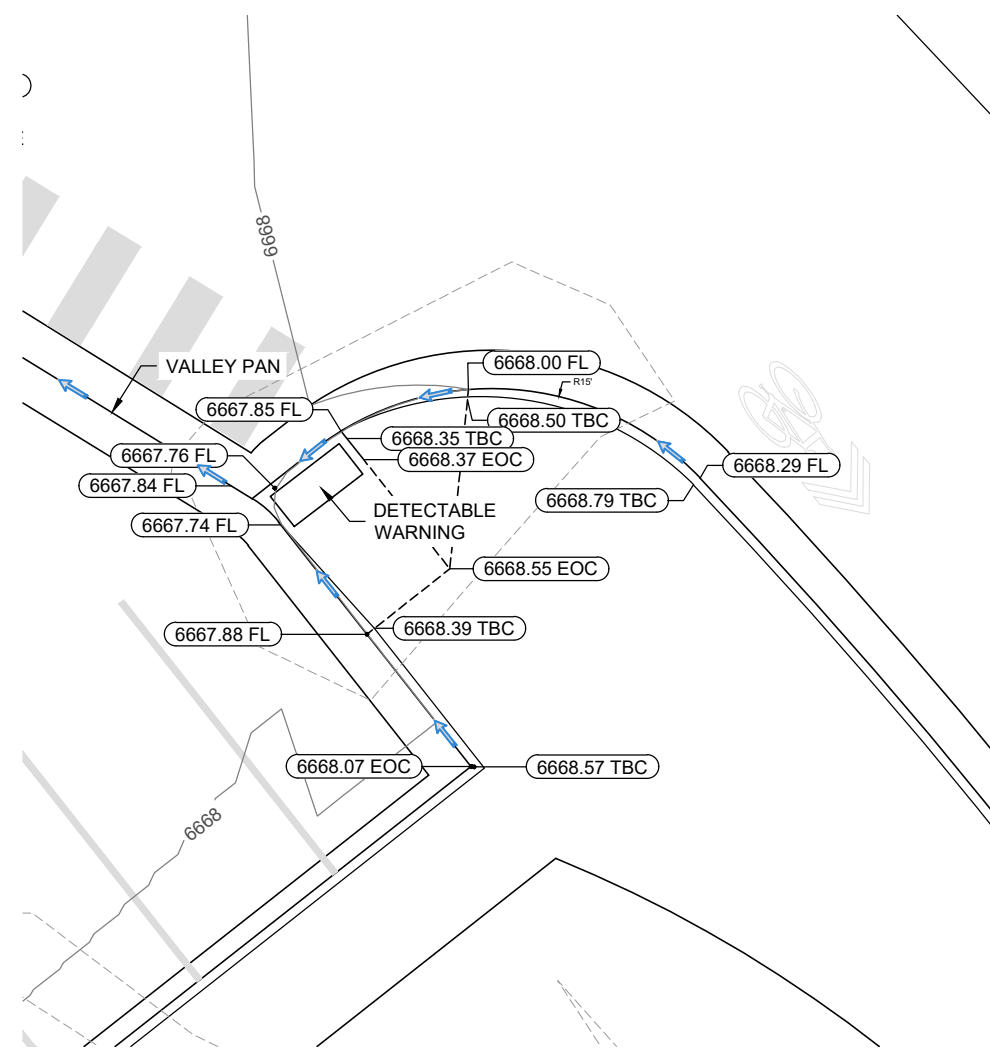

LANDING 3
1"=10'

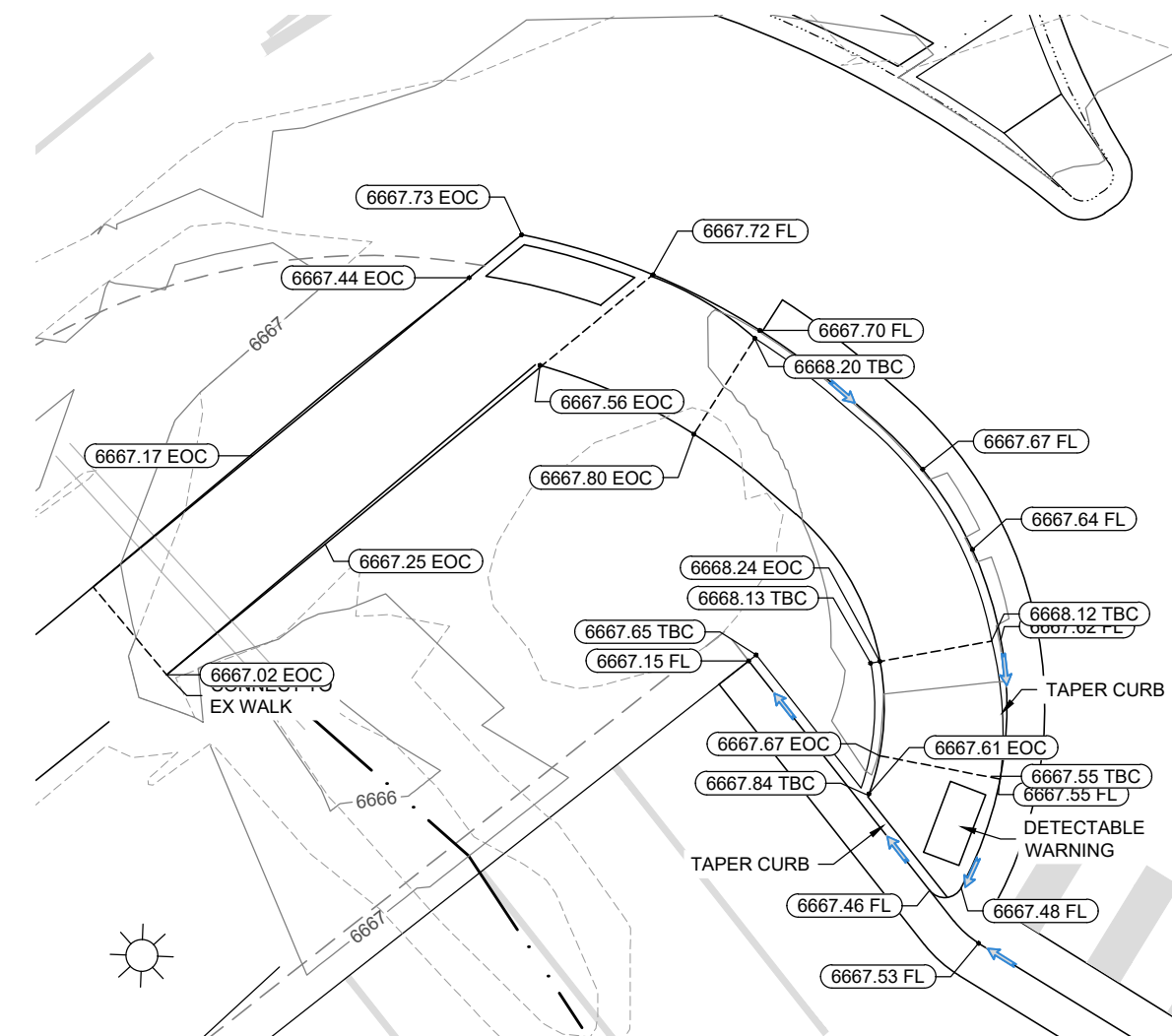

LANDING 4
1"=10'

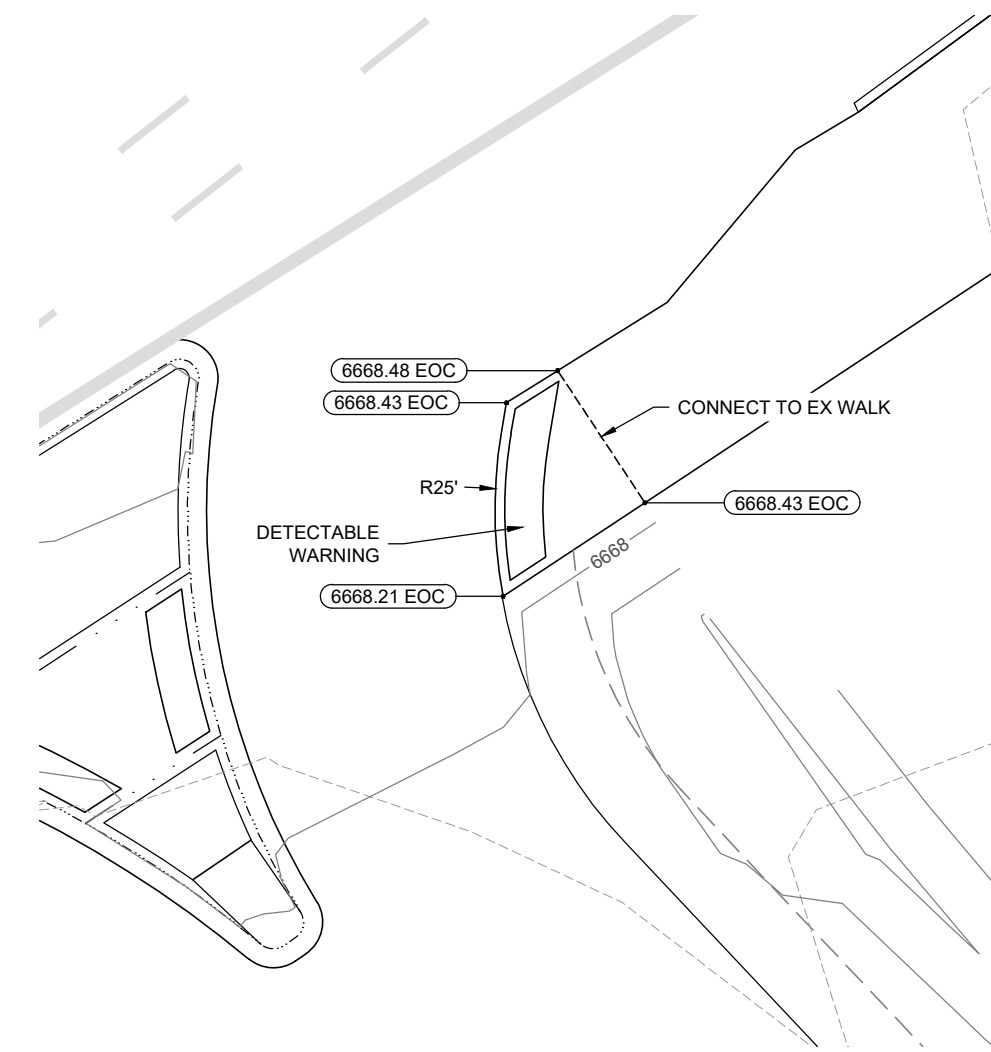

LANDING 5
1"=10'

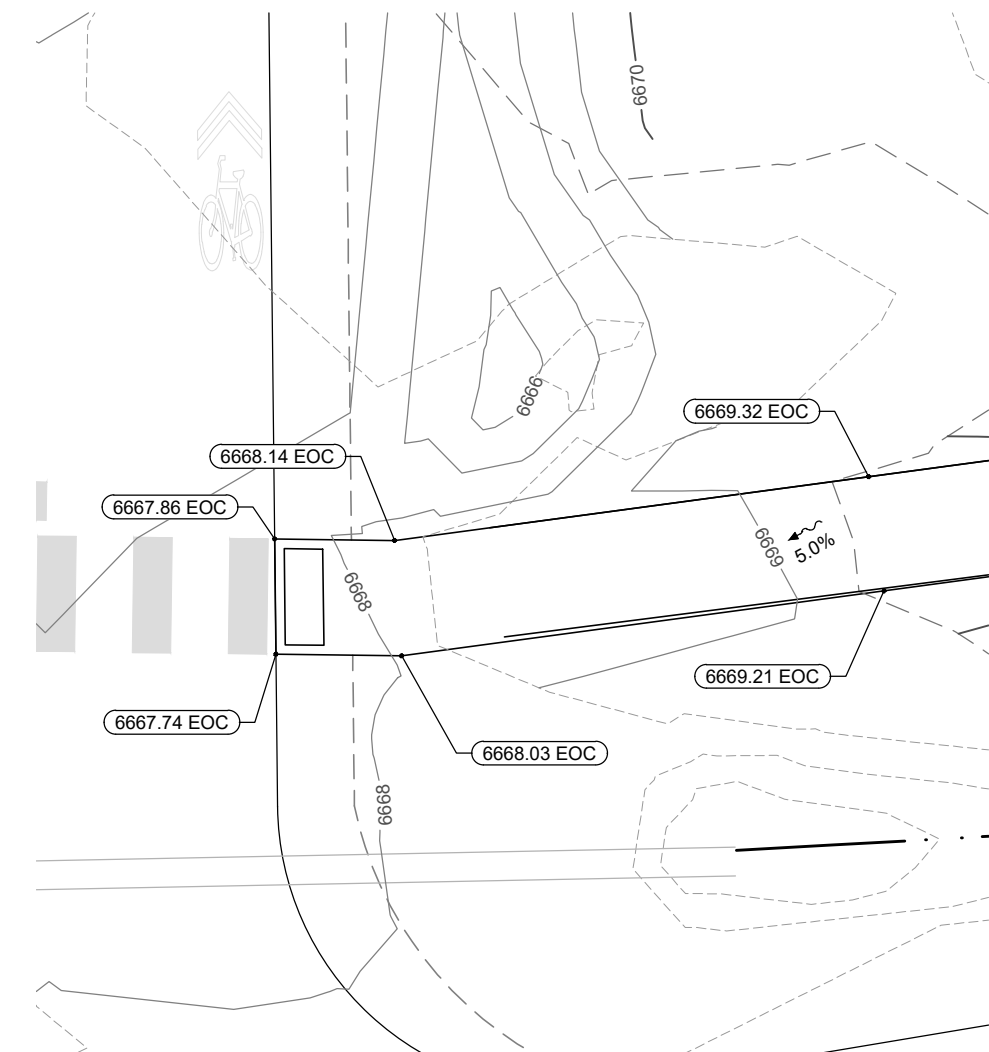

LANDING 2
1"=10'

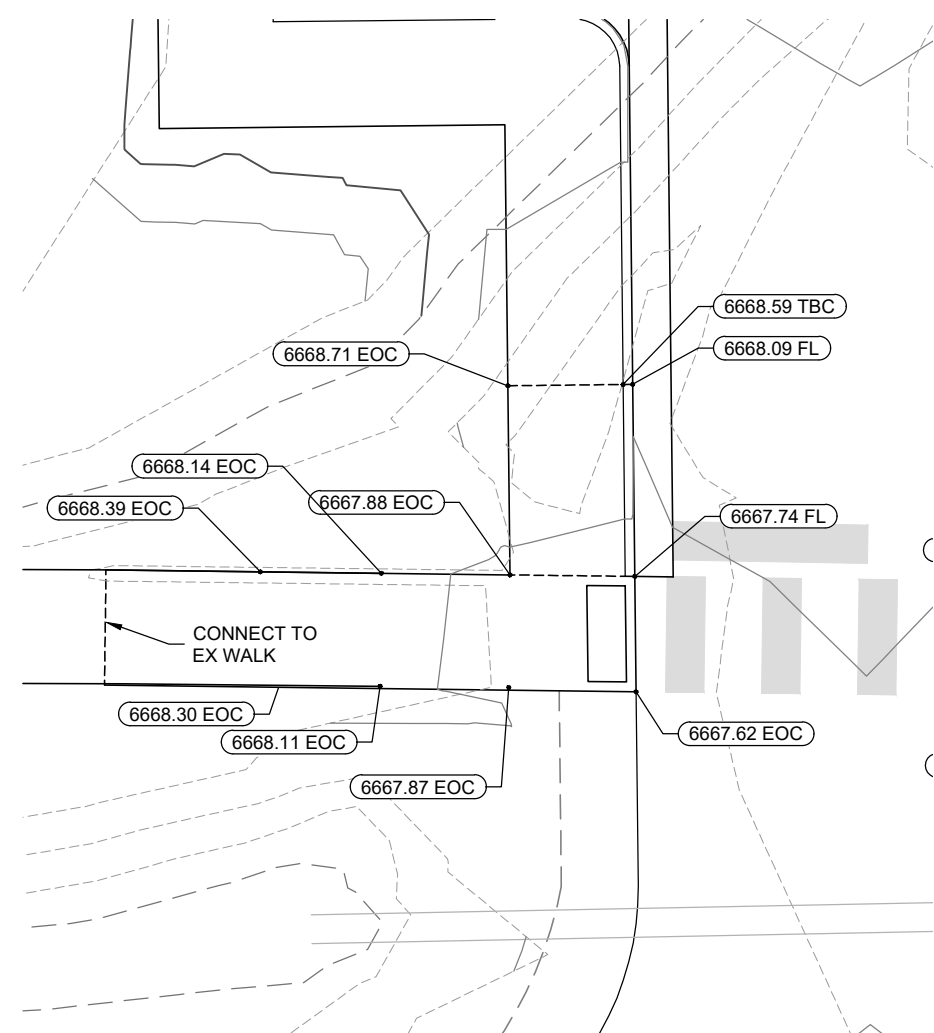

LANDING 1
1"=10'

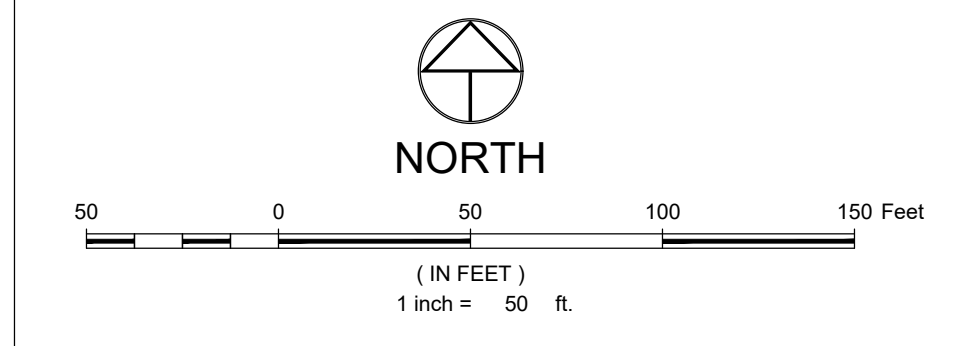
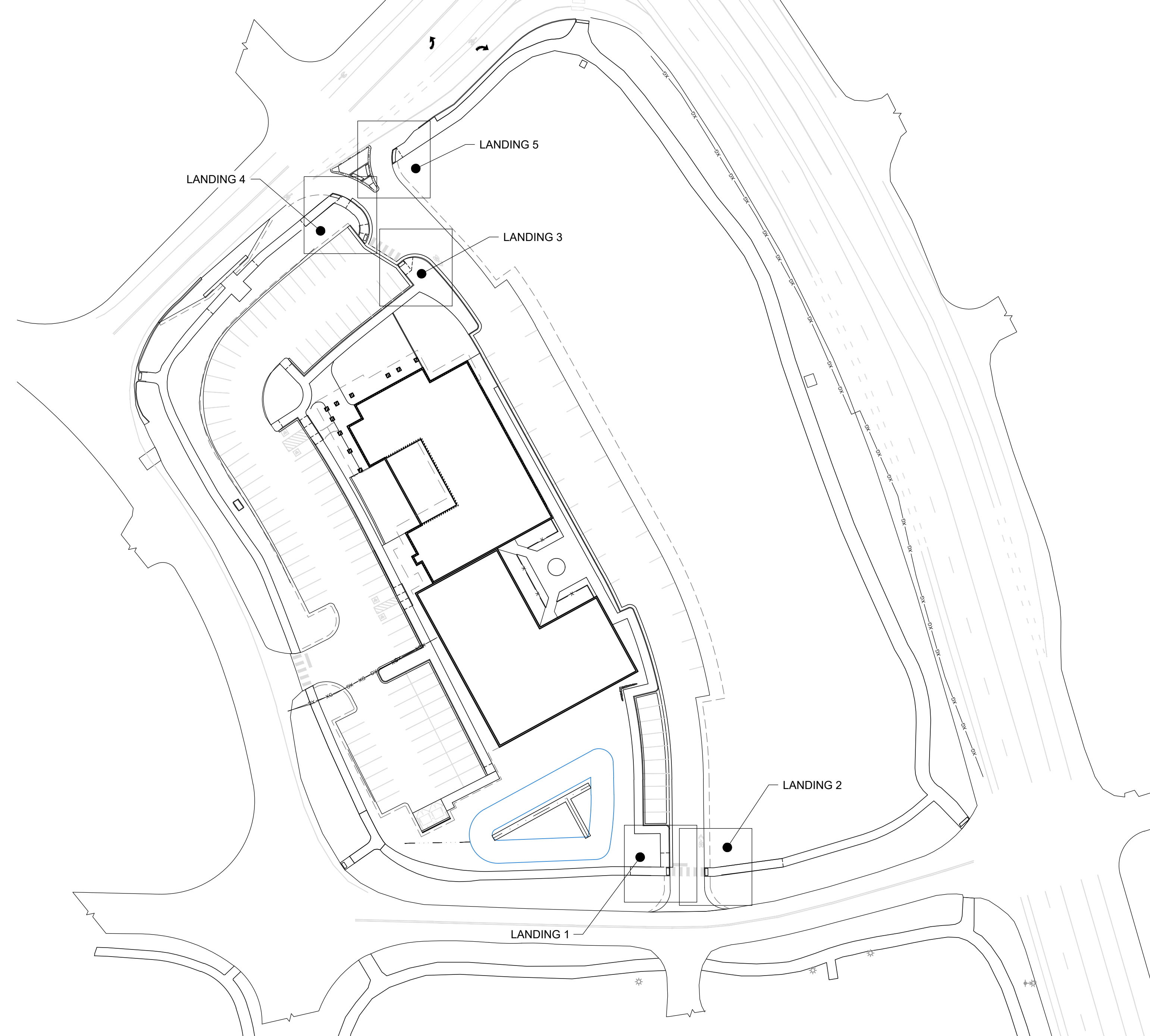

LEGEND:

- EXISTING STORM SEWER
- PROPOSED STORM SEWER
- PROPOSED STORM INLET (CURB & AREA)
- PROPOSED MAJOR CONTOUR
- PROPOSED MINOR CONTOUR
- EXISTING MAJOR CONTOUR
- EXISTING MINOR CONTOUR
- PROPOSED SWALE
- PROPOSED CURB & GUTTER
- PROPERTY BOUNDARY
- PROPOSED LOT LINE
- EXISTING RIGHT OF WAY
- FLOOD HAZARD LIMITS
- PROPOSED SPOT ELEVATION
- EXISTING SPOT ELEVATION
- PROPOSED OVERLAND FLOW DIRECTION W/SLOPE
- PROPOSED CHANNELIZED FLOW DIRECTION W/ SLOPE
- EXISTING CHANNELIZED FLOW DIRECTION

NOTES:

1. THE SIZE, TYPE AND LOCATION OF ALL KNOWN UNDERGROUND UTILITIES ARE APPROXIMATE WHEN SHOWN ON THESE DRAWINGS. IT SHALL BE THE RESPONSIBILITY OF THE DEVELOPER TO VERIFY THE EXISTENCE OF ALL UNDERGROUND UTILITIES IN THE AREA OF THE WORK. BEFORE COMMENCING NEW CONSTRUCTION, THE CONTRACTOR SHALL BE RESPONSIBLE FOR LOCATING ALL UNDERGROUND UTILITIES AND SHALL BE RESPONSIBLE FOR ALL UNKNOWN UNDERGROUND UTILITIES.
2. ALL PROJECT DATA IS ON VERTICAL DATUM: NAVD 88. SEE COVER SHEET FOR BENCHMARK REFERENCES.
3. ELEVATIONS FOR IMPROVEMENTS THAT ARE CONTROLLED BY ADJACENT EXISTING FACILITIES (SUCH AS PROPOSED GUTTERS ALONG EXISTING ASPHALT) MAY REQUIRE ADJUSTMENT BASED ON ACTUAL CONDITIONS. COORDINATE WITH ENGINEER TO ENSURE A CONSISTENT SECTION WITH SMOOTH TRANSITIONS WHERE NECESSARY.
4. SEE SOILS REPORT FOR PAVEMENT, SUBGRADE AND MATERIAL PREPARATION, DESIGN AND RECOMMENDATIONS.
5. ALL CURB SPOTS SHOWN ARE FLOWLINE ELEVATIONS, UNLESS NOTED OTHERWISE. ALL OTHER SPOTS ARE FINISHED GRADE ELEVATIONS.

CALL UTILITY NOTIFICATION CENTER OF COLORADO

 Know what's below. Call before you dig.
 CALL 2 BUSINESS DAYS IN ADVANCE BEFORE YOU DIG, GRADE, OR EXCAVATE FOR THE MARKING OF UNDERGROUND MEMBER UTILITIES.

NOT VALID WITHOUT ORIGINAL SIGNATURE AND DATE

CIVIL ENGINEERS | SURVEYORS
 141 9th Street - P.O. Box 74843
 Steamboat, Colorado 80477
 (970) 871-9494
 www.LANDMARK-co.com

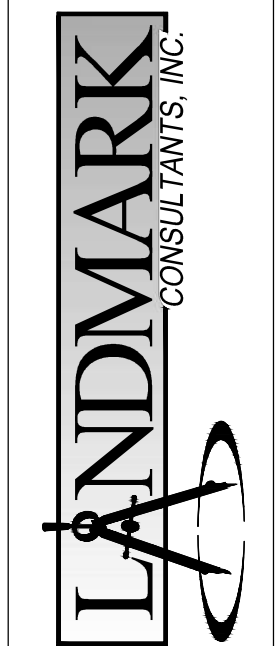

THIS SET OF DRAWINGS IS THE PROPERTY OF LANDMARK CONSULTANTS, INC. AND IS NOT TO BE REPRODUCED, COPIED, OR TRANSMITTED IN ANY FORM OR BY ANY MEANS, ELECTRONIC OR MECHANICAL, INCLUDING PHOTOCOPYING, RECORDING, OR BY ANY INFORMATION STORAGE AND RETRIEVAL SYSTEM, WITHOUT THE WRITTEN PERMISSION OF LANDMARK CONSULTANTS, INC.

NO.	DATE	BY:	DESCRIPTION
2387-04	1-28-22	GHp	

PROJECT: 2387-04
 DATE: 1-28-22
 CONTACT: GHp
 EMAIL: enreg@landmark-co.com

Steamboat Basecamp - Phase I
 Landing Details

SHEET
C.310

DRAWING FILENAME: P:\2022\02\02\Production\Drawings\Phase I - Curb\CD2387-04\141 9th St\CD-C-310.Landing Details.dwg, LAYOUT NAME: C.310, DATE: Jan 28, 2022, 11:53am CAD OPERATOR: wjk
 LIST OF SHEETS: (2387-04-01.dwg) (2387-04-02.dwg) (2387-04-03.dwg) (2387-04-04.dwg) (2387-04-05.dwg) (2387-04-06.dwg) (2387-04-07.dwg) (2387-04-08.dwg) (2387-04-09.dwg) (2387-04-10.dwg)

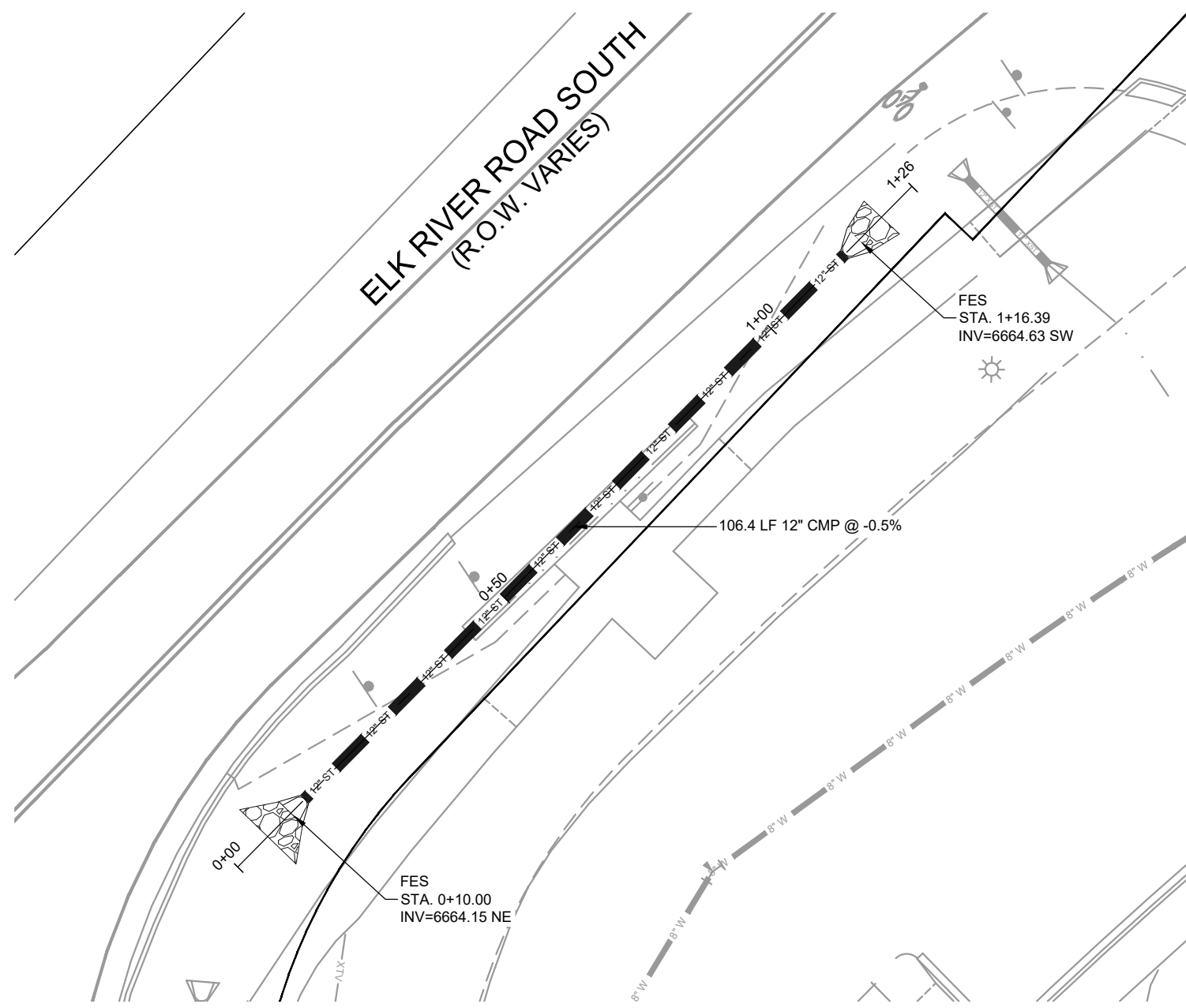

BUS STOP CULVERT
STORM SEWER PLAN & PROFILE (STA 0+00 - 1+26)

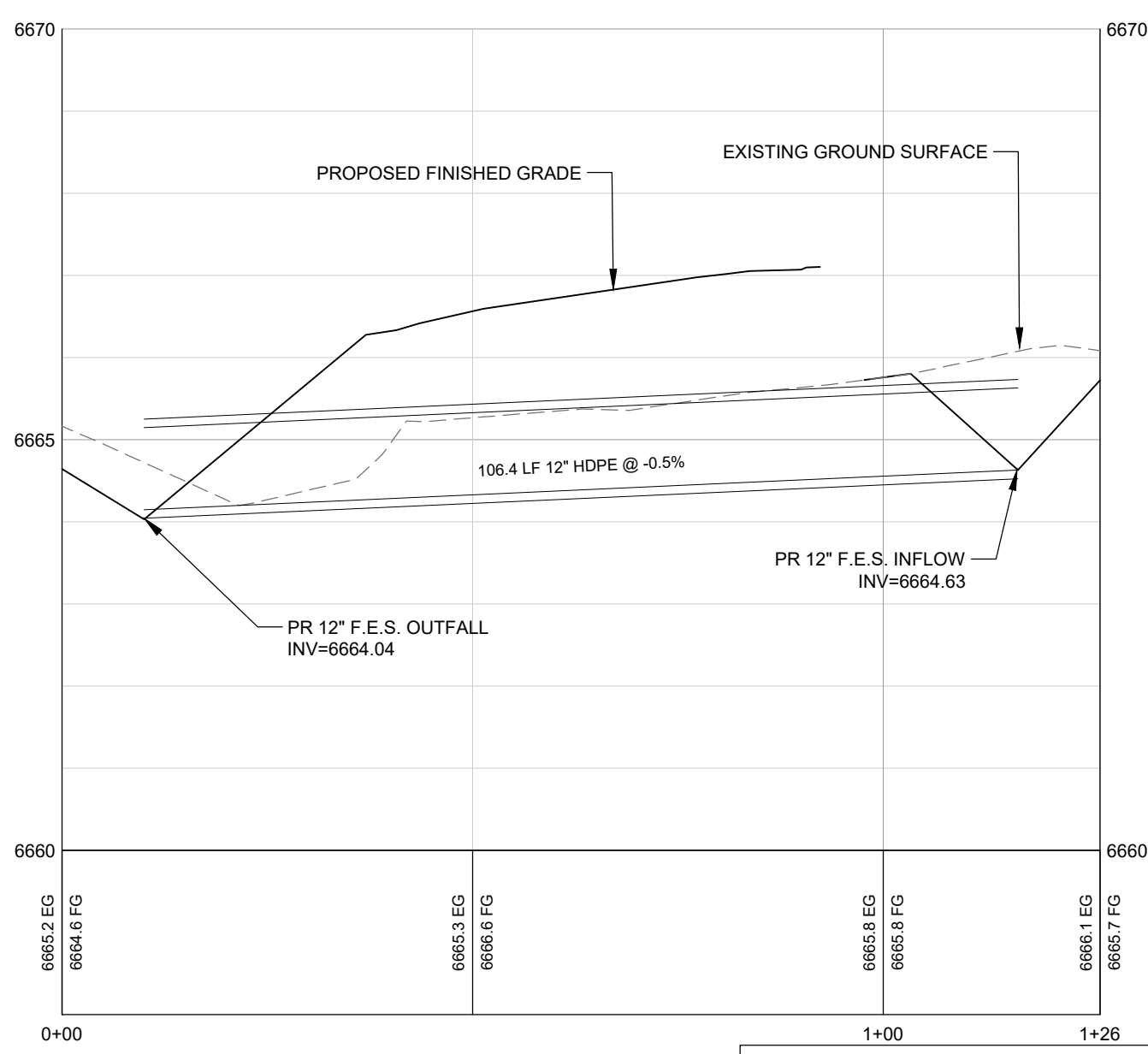

STORM SEWER PROFILE
CENTERLINE
SCALE: 1" = 20' (H) 1" = 2' (V)

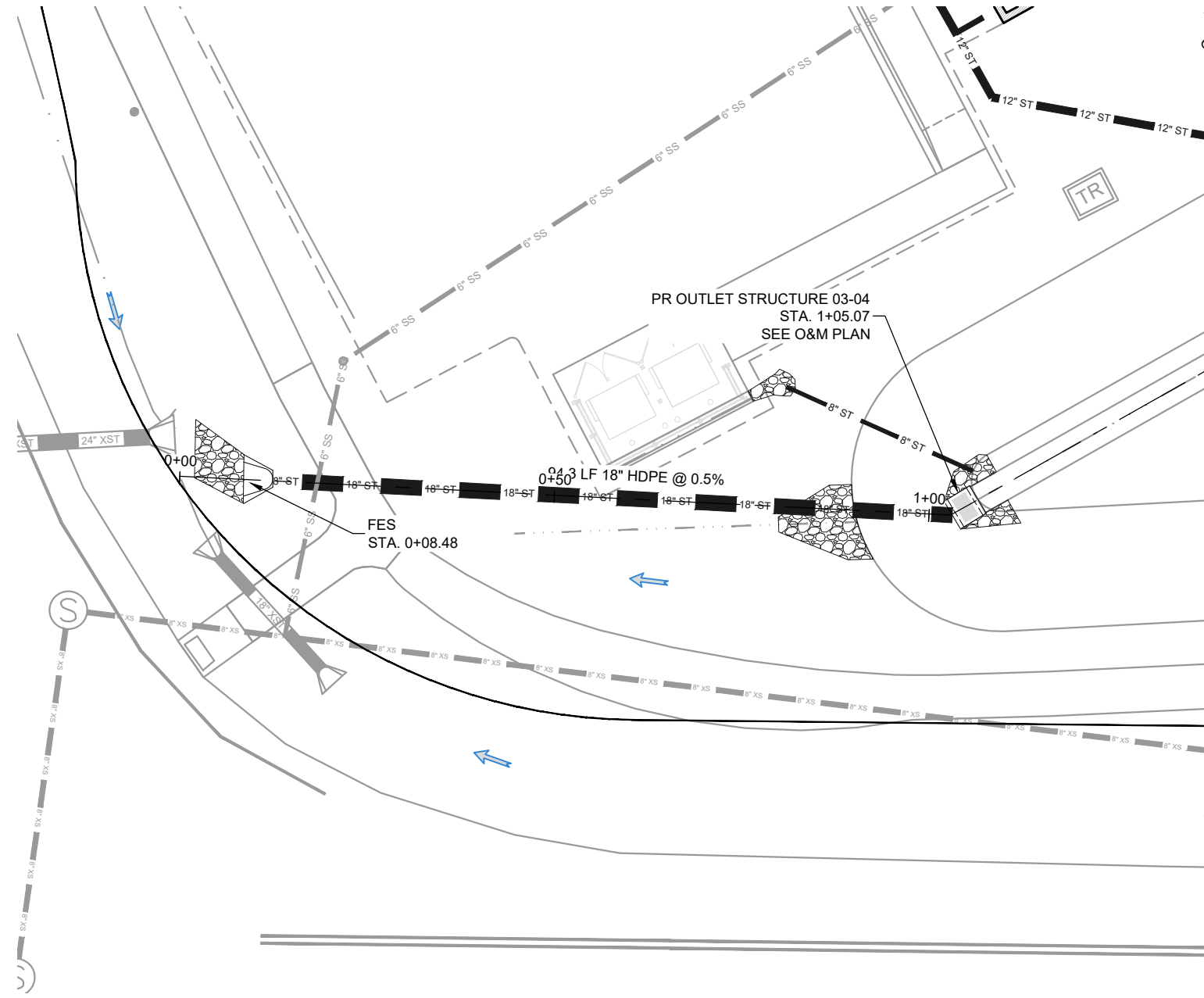

POND OUTLET
STORM SEWER PLAN & PROFILE (STA 0+00 - 1+70)

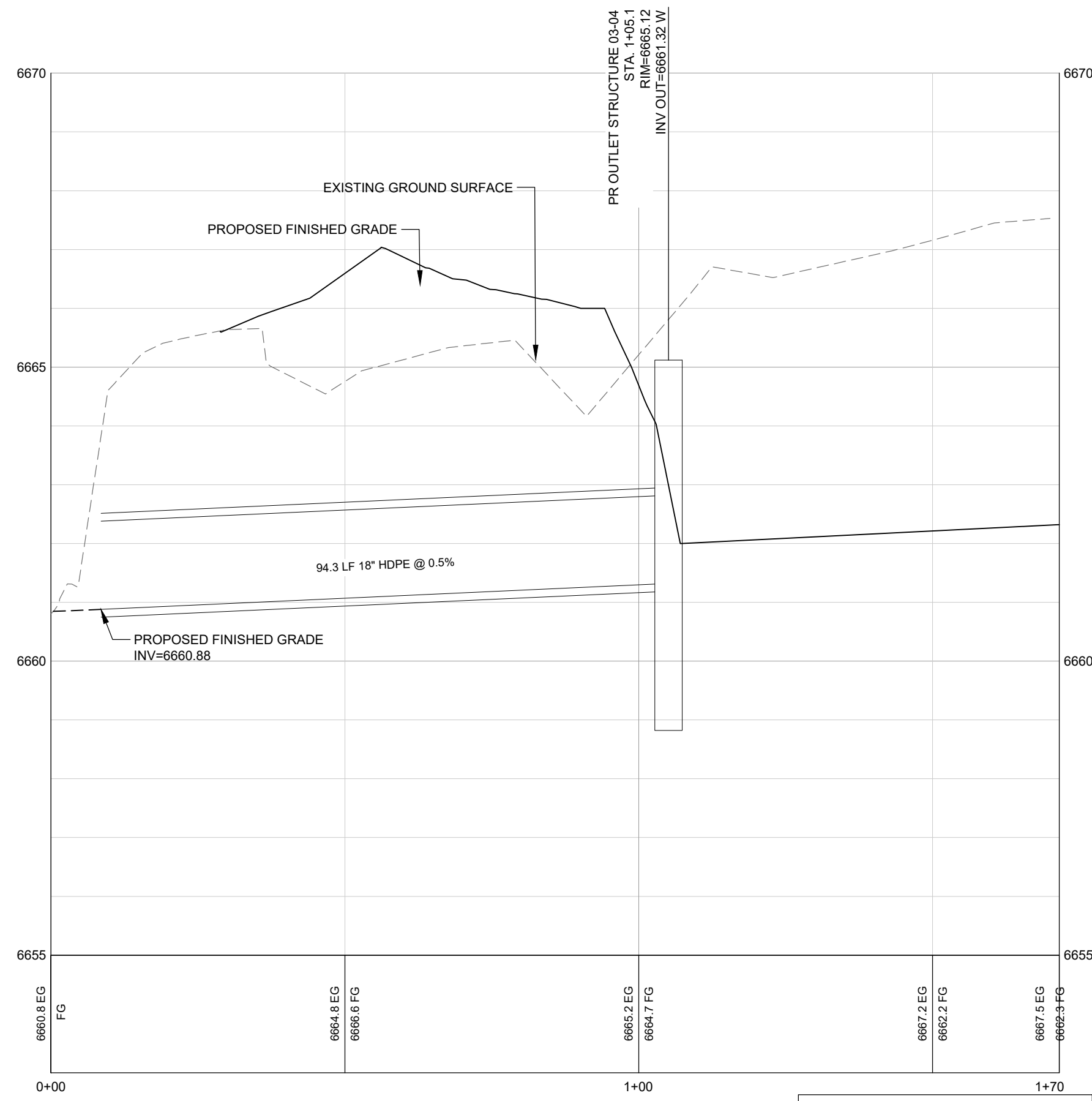

STORM SEWER PROFILE
CENTERLINE
SCALE: 1" = 20' (H) 1" = 2' (V)

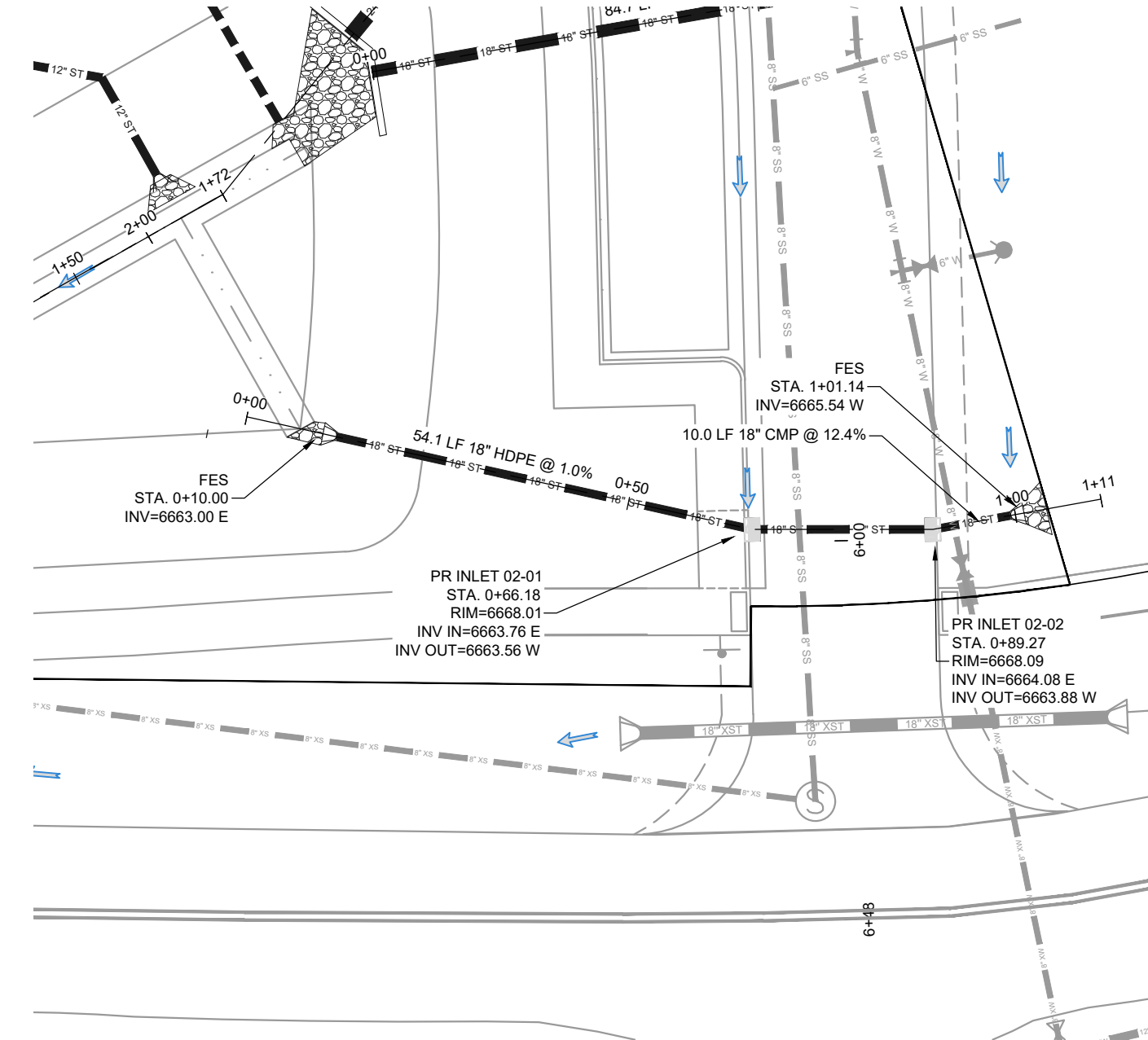

STORM SEWER 2
STORM SEWER PLAN & PROFILE (STA 0+00 - 1+17)

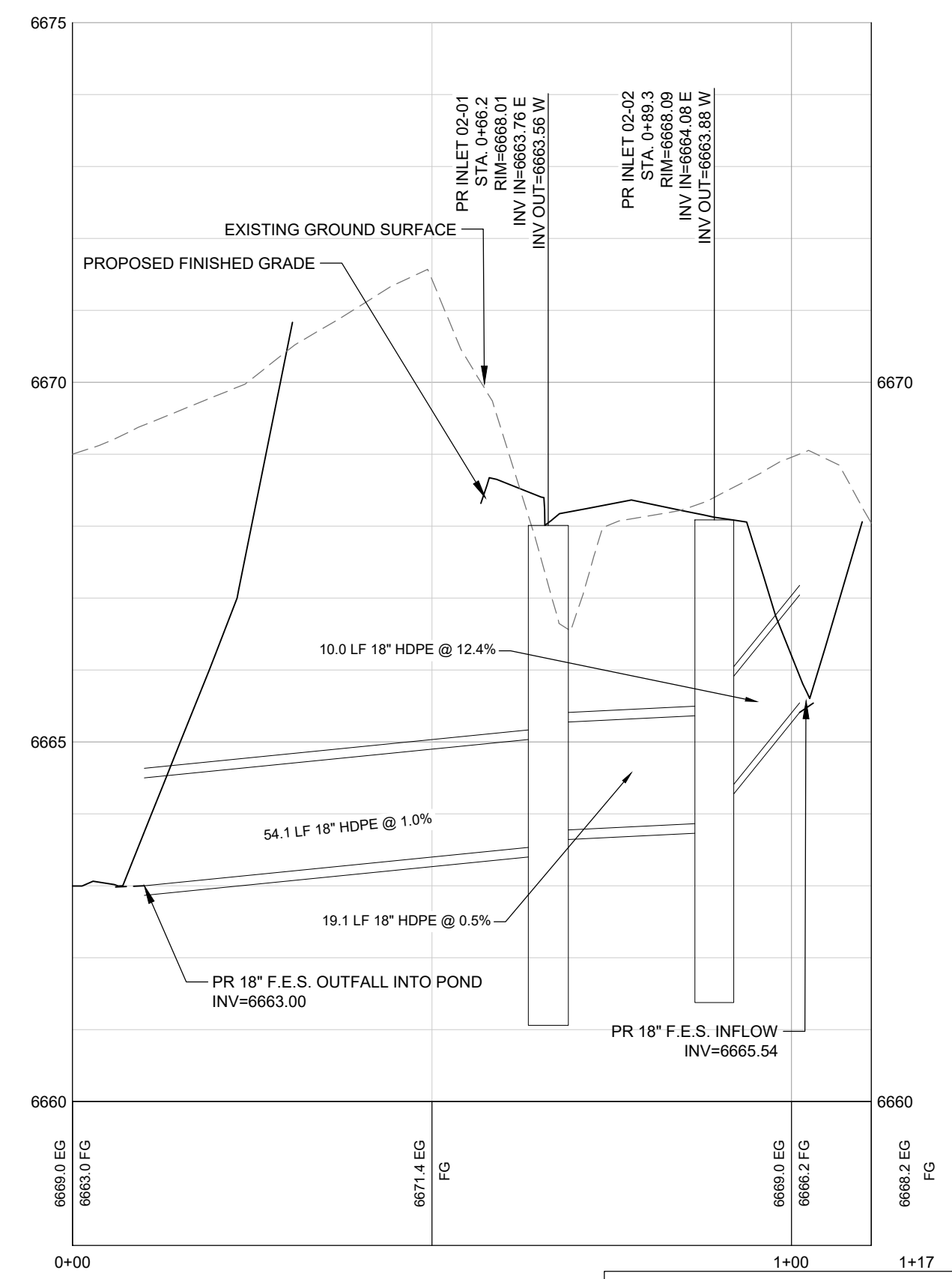

STORM SEWER PROFILE
CENTERLINE
SCALE: 1" = 20' (H) 1" = 2' (V)

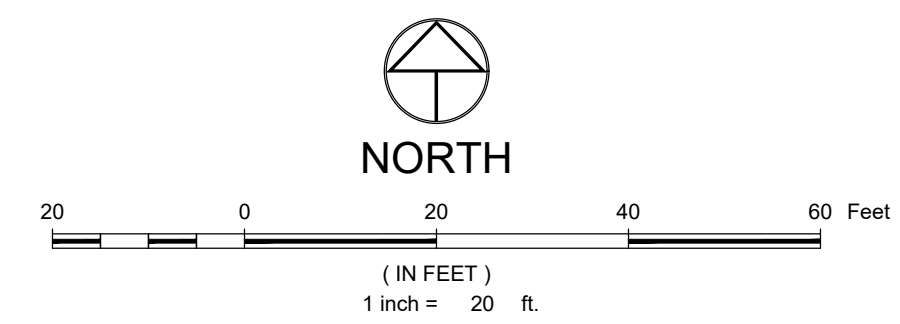

LEGEND:

- EXISTING STORM SEWER
- PROPOSED STORM SEWER
- PROPOSED STORM INLET (CURB & AREA)
- PROPOSED MAJOR CONTOUR
- PROPOSED MINOR CONTOUR
- EXISTING MAJOR CONTOUR
- EXISTING MINOR CONTOUR
- PROPOSED SWALE
- PROPOSED CURB & GUTTER
- PROPERTY BOUNDARY
- PROPOSED LOT LINE
- EXISTING RIGHT OF WAY
- FLOOD HAZARD LIMITS
- PROPOSED SPOT ELEVATION
- EXISTING SPOT ELEVATION
- PROPOSED OVERLAND FLOW DIRECTION W/SLOPE
- PROPOSED CHANNELIZED FLOW DIRECTION W/ SLOPE
- EXISTING CHANNELIZED FLOW DIRECTION

NOTES:

1. THE SIZE, TYPE AND LOCATION OF ALL KNOWN UNDERGROUND UTILITIES ARE APPROXIMATE WHEN SHOWN ON THESE DRAWINGS. IT SHALL BE THE RESPONSIBILITY OF THE DEVELOPER TO VERIFY THE EXISTENCE OF ALL UNDERGROUND UTILITIES IN THE AREA OF THE WORK. BEFORE COMMENCING NEW CONSTRUCTION, THE CONTRACTOR SHALL BE RESPONSIBLE FOR LOCATING ALL UNDERGROUND UTILITIES AND SHALL BE RESPONSIBLE FOR ALL UNKNOWN UNDERGROUND UTILITIES.
2. ALL PROJECT DATA IS ON VERTICAL DATUM: NAVD 88. SEE COVER SHEET FOR BENCHMARK REFERENCES.
3. ELEVATIONS FOR IMPROVEMENTS THAT ARE CONTROLLED BY ADJACENT EXISTING FACILITIES (SUCH AS PROPOSED GUTTERS ALONG EXISTING ASPHALT) MAY REQUIRE ADJUSTMENT BASED ON ACTUAL CONDITIONS. COORDINATE WITH ENGINEER TO ENSURE A CONSISTENT SECTION WITH SMOOTH TRANSITIONS WHERE NECESSARY.
4. SEE SOILS REPORT FOR PAVEMENT, SUBGRADE AND MATERIAL PREPARATION, DESIGN AND RECOMMENDATIONS.
5. ALL CURB SPOTS SHOWN ARE FLOWLINE ELEVATIONS, UNLESS NOTED OTHERWISE. ALL OTHER SPOTS ARE FINISHED GRADE ELEVATIONS.

CIVIL ENGINEERS | SURVEYORS
141 9th Street - P.O. Box 774843
Steamboat, Colorado 80477
(970) 871-9494
www.LANDMARK-co.com

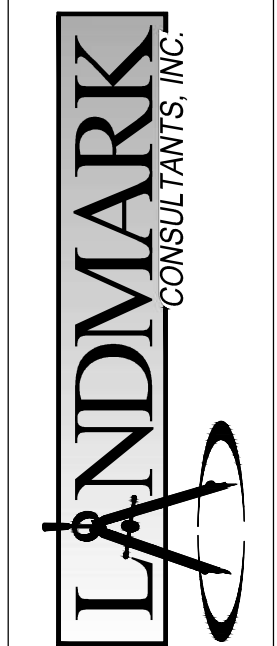

THIS SET OF DRAWINGS IS THE PROPERTY OF LANDMARK CONSULTANTS, INC. AND IS NOT TO BE REPRODUCED OR TRANSMITTED IN ANY FORM OR BY ANY MEANS, ELECTRONIC OR MECHANICAL, INCLUDING PHOTOCOPYING, RECORDING, OR BY ANY INFORMATION STORAGE AND RETRIEVAL SYSTEM, WITHOUT THE WRITTEN PERMISSION OF LANDMARK CONSULTANTS, INC.

NO.	DESCRIPTION	DATE	BY

PROJECT: 2387-04
DATE: 1-28-22
CONTACT: GHP
EMAIL: en@landmark-co.com

Steamboat Basecamp - Phase I
Detailed Storm Sewer Plan & Profile

SHEET
C.312

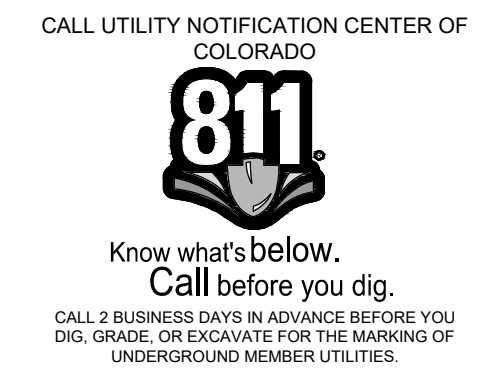

NOT VALID WITHOUT ORIGINAL SIGNATURE AND DATE

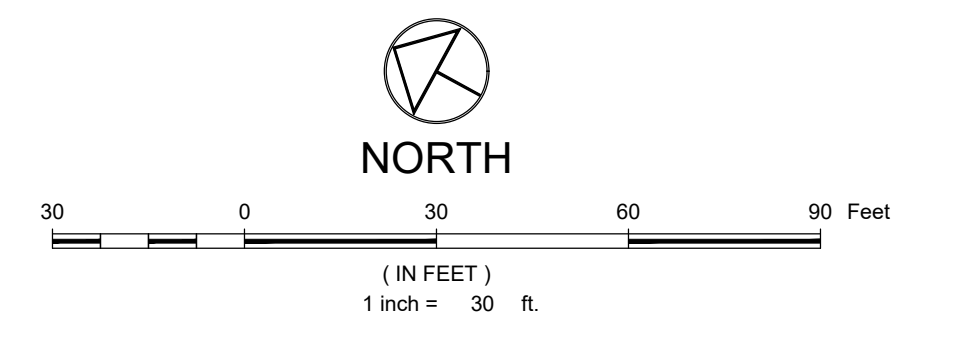
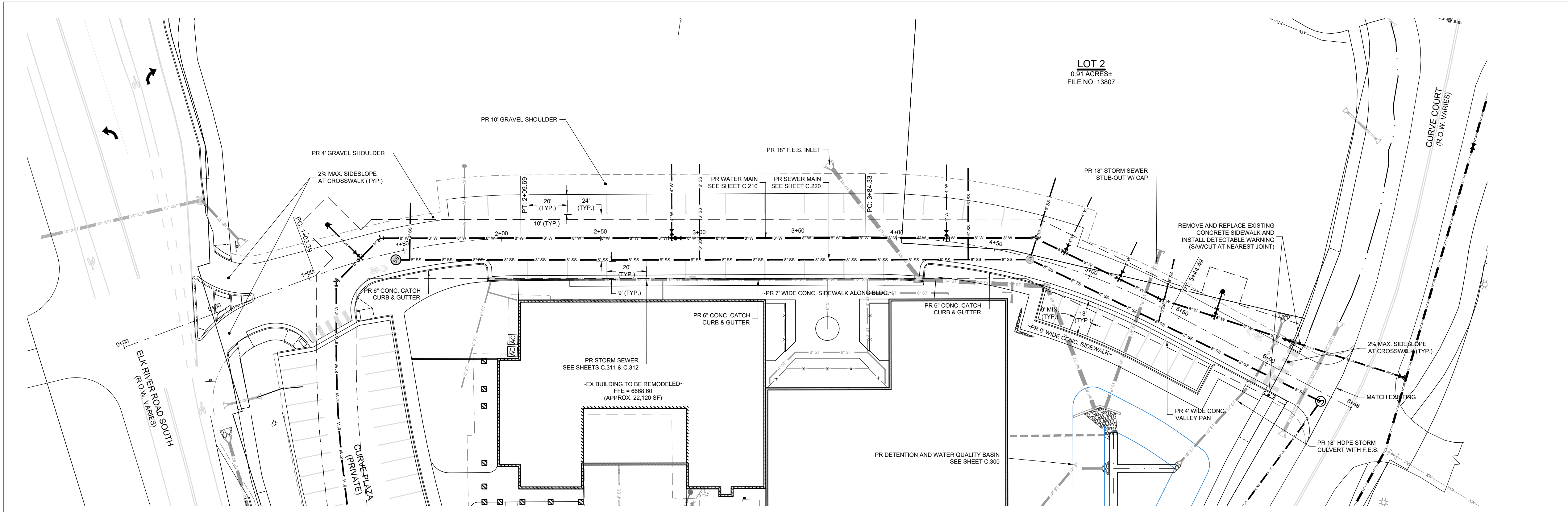

LEGEND:

- EXISTING STORM SEWER
- PROPOSED STORM SEWER
- PROPOSED STORM INLET (CURB & AREA)
- PROPOSED MAJOR CONTOUR
- PROPOSED MINOR CONTOUR
- EXISTING MAJOR CONTOUR
- EXISTING MINOR CONTOUR
- PROPOSED SWALE
- PROPOSED CURB & GUTTER
- PROPERTY BOUNDARY
- PROPOSED LOT LINE
- EXISTING RIGHT OF WAY
- FLOOD HAZARD LIMITS

PROPOSED SPOT ELEVATION: 00.10 X

EXISTING SPOT ELEVATION: 00.10 X

PROPOSED OVERLAND FLOW DIRECTION W/SLOPE: 2.0%

PROPOSED CHANNELIZED FLOW DIRECTION W/ SLOPE: 2.0%

EXISTING CHANNELIZED FLOW DIRECTION

- NOTES:**
- THE SIZE, TYPE AND LOCATION OF ALL KNOWN UNDERGROUND UTILITIES ARE APPROXIMATE WHEN SHOWN ON THESE DRAWINGS. IT SHALL BE THE RESPONSIBILITY OF THE DEVELOPER TO VERIFY THE EXISTENCE OF ALL UNDERGROUND UTILITIES IN THE AREA OF THE WORK. BEFORE COMMENCING NEW CONSTRUCTION, THE CONTRACTOR SHALL BE RESPONSIBLE FOR LOCATING ALL UNDERGROUND UTILITIES AND SHALL BE RESPONSIBLE FOR ALL UNKNOWN UNDERGROUND UTILITIES.
 - ALL PROJECT DATA IS ON VERTICAL DATUM; NAVD 88. SEE COVER SHEET FOR BENCHMARK REFERENCES.
 - ELEVATIONS FOR IMPROVEMENTS THAT ARE CONTROLLED BY ADJACENT EXISTING FACILITIES (SUCH AS PROPOSED GUTTERS ALONG EXISTING ASPHALT) MAY REQUIRE ADJUSTMENT BASED ON ACTUAL CONDITIONS. COORDINATE WITH ENGINEER TO ENSURE A CONSISTENT SECTION WITH SMOOTH TRANSITIONS WHERE NECESSARY.
 - SEE SOILS REPORT FOR PAVEMENT, SUBGRADE AND MATERIAL PREPARATION, DESIGN AND RECOMMENDATIONS.
 - ALL CURB SPOTS SHOWN ARE FLOWLINE ELEVATIONS, UNLESS NOTED OTHERWISE. ALL OTHER SPOTS ARE FINISHED GRADE ELEVATIONS.

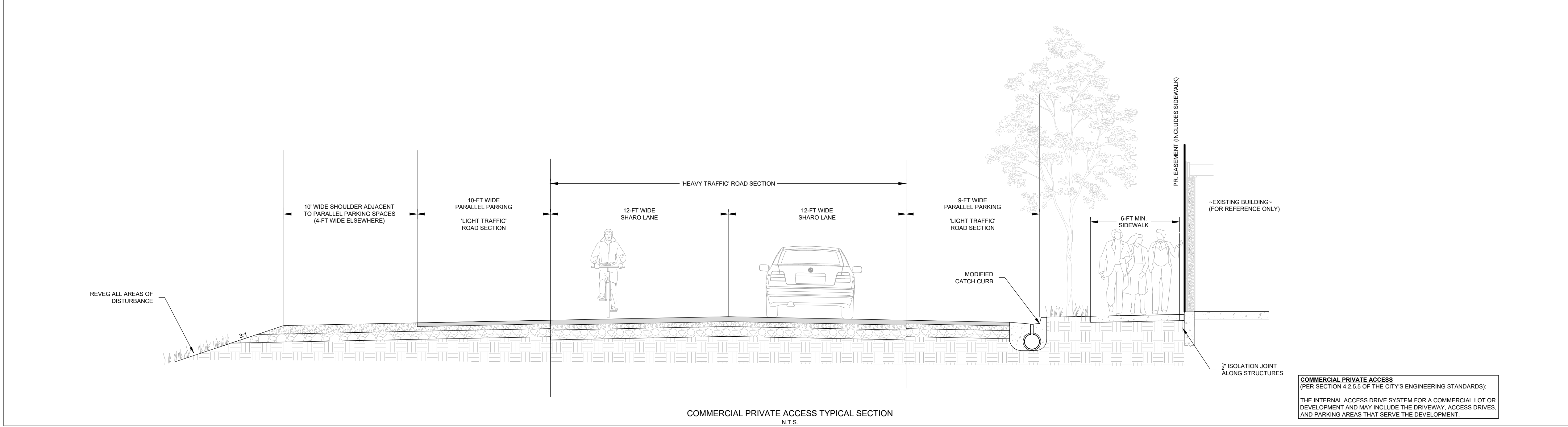
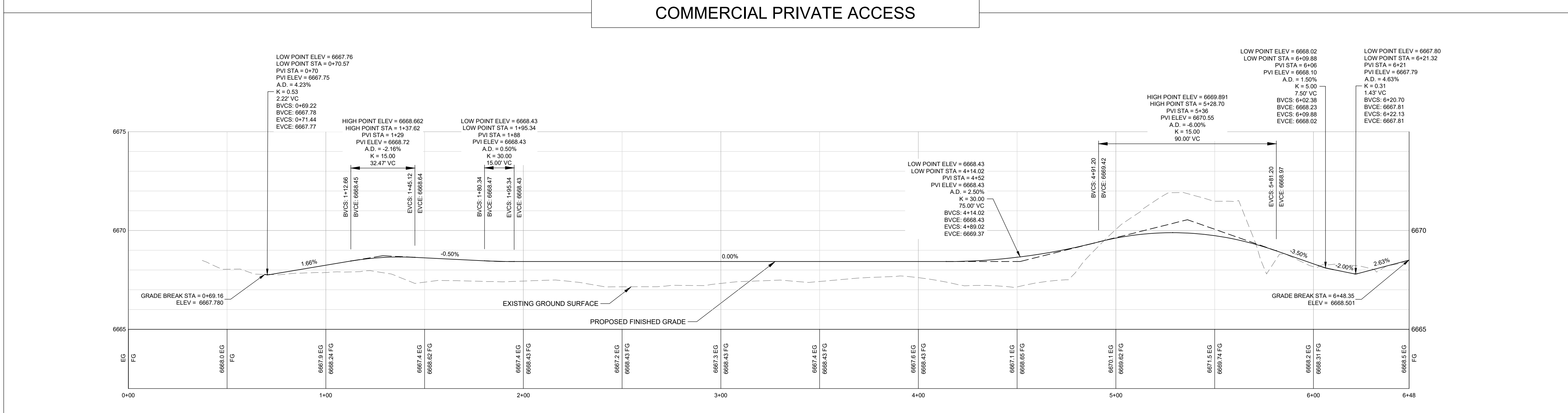

CALL UTILITY NOTIFICATION CENTER OF COLORADO

Know what's below. Call before you dig.

CALL 2 BUSINESS DAYS IN ADVANCE BEFORE YOU DIG, GRADE, OR EXCAVATE FOR THE MARKING OF UNDERGROUND MEMBER UTILITIES.

NOT VALID WITHOUT ORIGINAL SIGNATURE AND DATE

CIVIL ENGINEERS | SURVEYORS

141 9th Street - P.O. Box 774843
Steamboat, Colorado 80477
(970) 871-9494
www.LANDMARK-CD.com

PLEASE PRINT: PROJECT NO. 2387-04, PROJECT: Steamboat Basecamp - Phase I, DATE: 1-28-22, BY: GHP, CONTACT: enrg@landmark-co.com, EMAIL: enrg@landmark-co.com

Access Road Plan & Profile

SHEET C.410

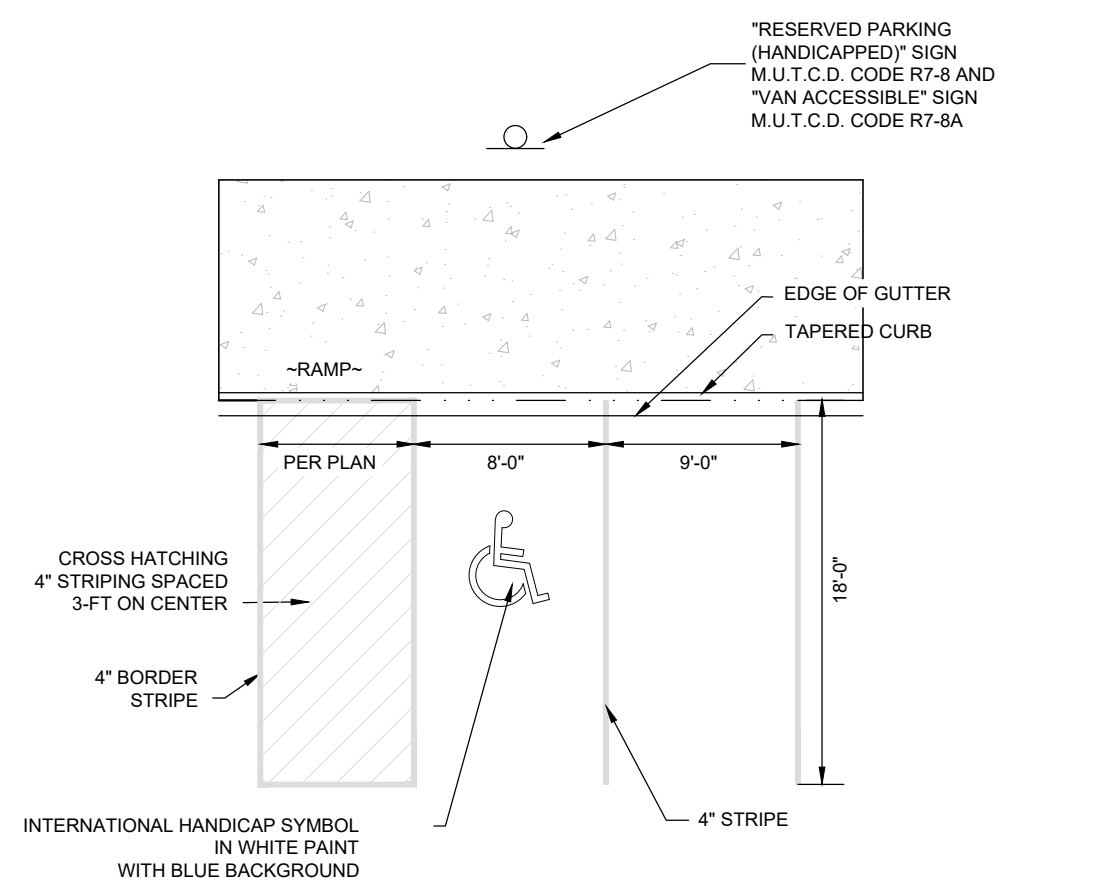

- PAVEMENT MARKING NOTES:**
1. PAVEMENT MARKING PAINT SHALL BE WHITE LATEX, WATERBORNE EMULSION, LEAD AND CHROMATE FREE, READY MIXED, COMPLYING WITH FHWA-1052, WITH DRYING TIME LESS THAN 45 MINUTES.
 2. PAINT PAVEMENT MARKINGS ONLY ON CLEAN, DRY SURFACES AND AT A MINIMUM AMBIENT OR SURFACE TEMPERATURE OF 50° F AND MAXIMUM AMBIENT OR SURFACE TEMPERATURE OF 95° DEG F.

TYPICAL STRIPED PARKING LAYOUT
N.T.S.

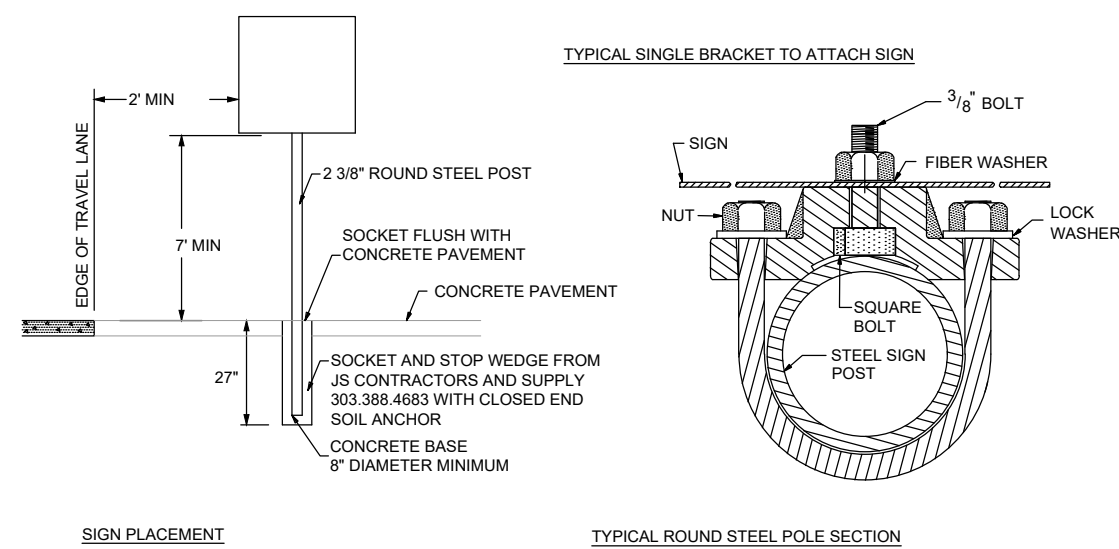

- SIGN PLACEMENT NOTES:**
1. CONFIRM LOCATION OF EACH SIGN IN FIELD WITH ENGINEER PRIOR TO INSTALLATION.

SIGN INSTALLATION DETAIL
N.T.S.

NOTES:

1. SEE PLAN FOR DIMENSIONS.
2. SEE GRADING PLAN FOR SLOPE AND ELEVATION INFORMATION.
3. 2% MAXIMUM GROSS SLOPE WITHIN SIDEWALK ZONE.
4. AT A MINIMUM, SUBGRADE PREPARATION SHOULD CONSIST OF SCARIFICATION TO APPROXIMATELY 8 INCHES AND THEN MOISTURE CONDITION AND COMPACTION.
5. COMPACT ALL FILL AREAS TO 95% STANDARD PROCTOR @ 12% OPTIMUM. REMOVE ALL TOPSOIL PRIOR TO SUBGRADE PREPARATION.
6. CONTRACTOR TO SUBMIT JOINT PLAN TO ENGINEER FOR REVIEW PRIOR TO PLACEMENT OF CONCRETE. COORINATE FINAL SIGNAGE AND DELINEATOR LOCATION WITH ENGINEER BEFORE PLACING CONCRETE. CORING INTO PROPOSED (VS. EXISTING) CONCRETE IS NOT ALLOWED. SLEEVES FOR SIGNS SHALL BE 8" DIAMETER PIPE, MIN. 12' LONG, WITH TOP SET FLUSH WITH FINAL GRADE.

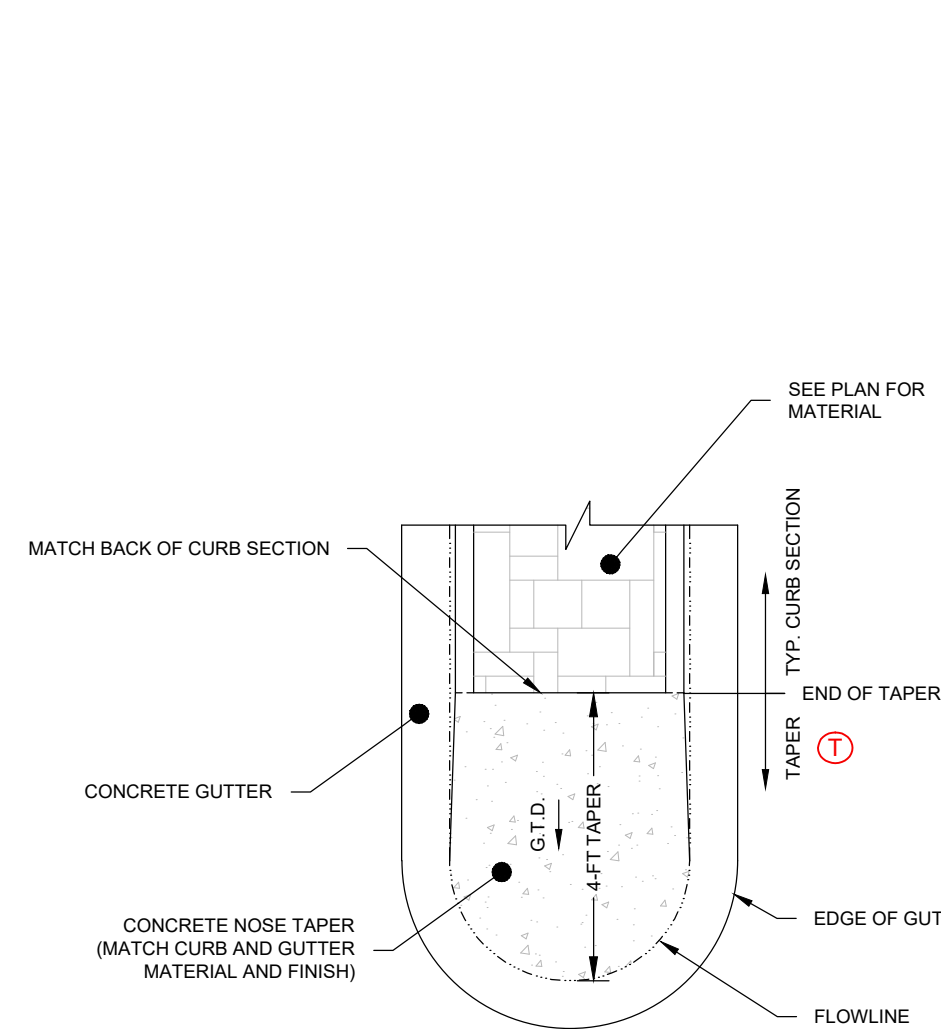

NOSE TAPER
N.T.S.

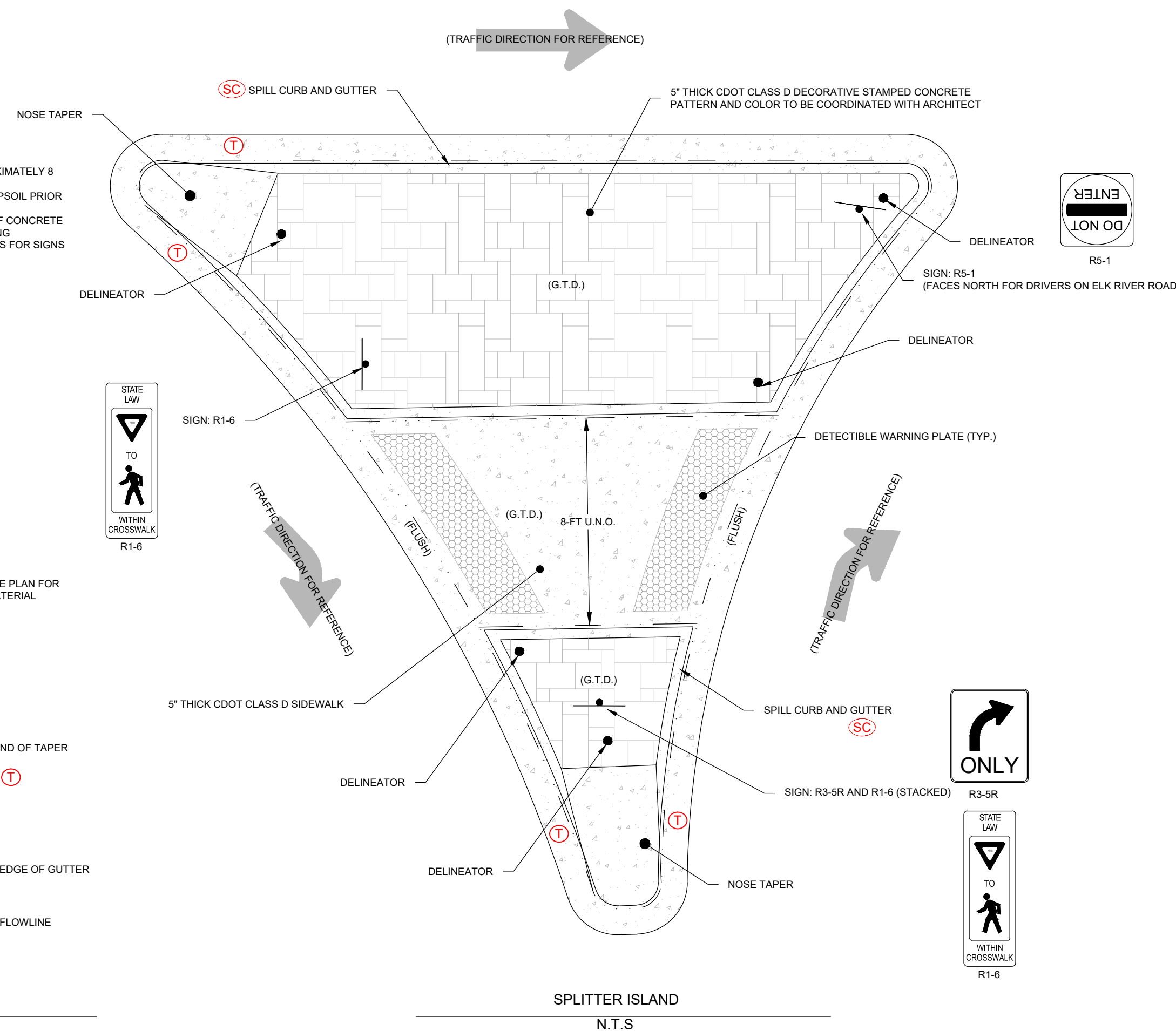

SPLITTER ISLAND
N.T.S.

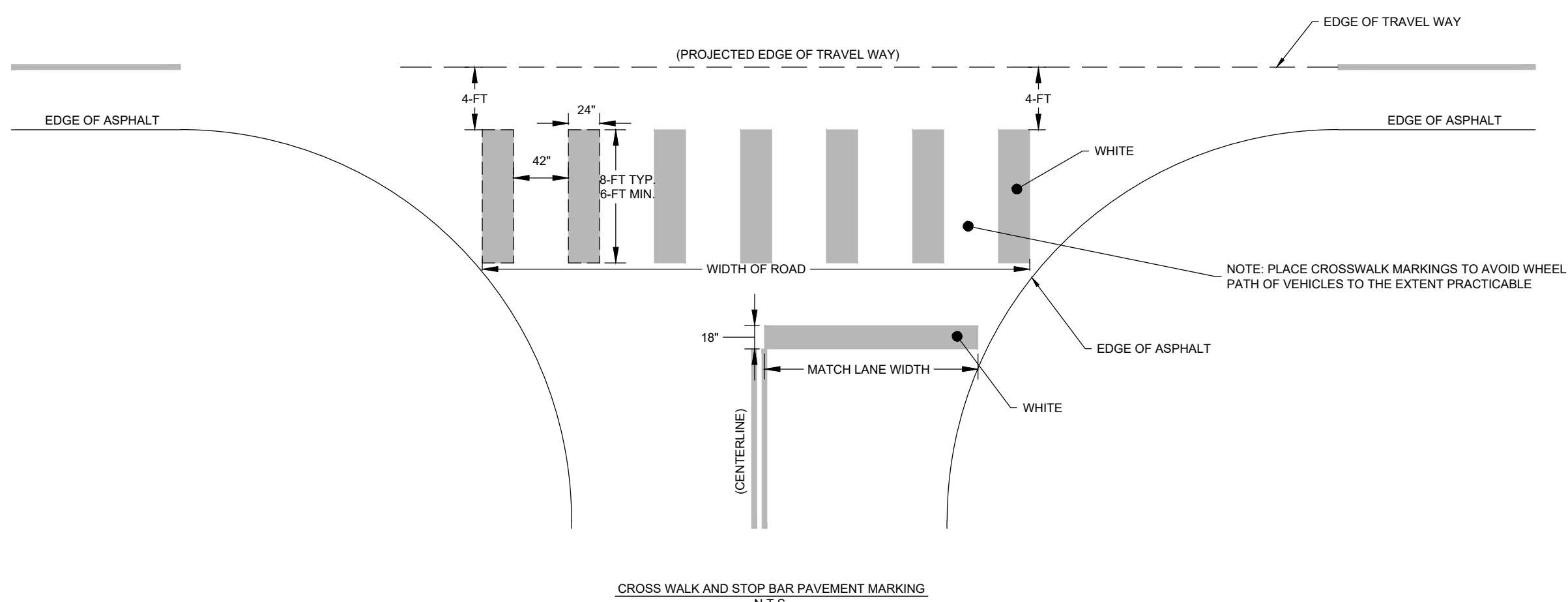

CROSS WALK AND STOP BAR PAVEMENT MARKING
N.T.S.

SOIL ANCHORED POST TYPES

TYPE 1 HAZARD MARKER	TYPE 2 GUIDE POST	TYPE 3 CHANNELIZER	TYPE 4 MARKER POST
Round post, fluted on top with black oval cap, three 3" (76.2mm) reflective patches and Driveable Soil Anchor	Round post, fluted on top with black oval cap, one 3" (76.2mm) reflective patch and Driveable Soil Anchor	Round post with recessed cap, one 6" (152.4mm) reflective wrap and Driveable Soil Anchor	Round post with recessed cap, two 3" (76.2mm) reflective wraps and Driveable Soil Anchor

SOIL ANCHOR OPTIONS

1. 14" 18" OR 24" CLOSED END SOIL ANCHOR
2. 14" 18" OR 24" OPEN END SOIL ANCHOR
3. 8" OPEN END CONCRETE ANCHOR

SPECIFICATIONS

Overall Post Height: 61 cm - 137 cm (24" - 54")
 Post Diameter: 5.7 cm (2.25")
 Soil Anchor Lengths: 20.32 cm - 61cm (8" - 24")
 Post Weight (22.2cm / 48"): 58 kg (1.5 lbs)
 Standard Post Colors: White, Yellow, Orange
 Custom Post Colors: Light Gray, Dark Gray, Green, Blue, Black, Brown or Red
 Reflective Sheeting: Standard high-intensity Silver, Amber or Orange. Other types and colors available.
 Installation Tools & Accessories: Manual Anchor Installation Tool, SH-6 Drive Tool Adapter, Anchor Straightening Tool, Post Removal Tool, Pilot Hole Tool, Drive Shafts & Adapters (for Jackhammer, Sfrister, Hammer power installation)

GUIDE POST DETAIL
N.T.S.

- NOTES:**
1. USE THE TYPE 2 GREEN GUIDE 54" POST WITH HIGH-INTENSITY ORANGE REFLECTOR.
 2. FOR SOIL ANCHOR APPLICATIONS, USE THE 18" CLOSED END ANCHOR.
 3. FOR LOCATIONS IN PAVED AREAS, USE OPEN END CONCRETE ANCHOR.

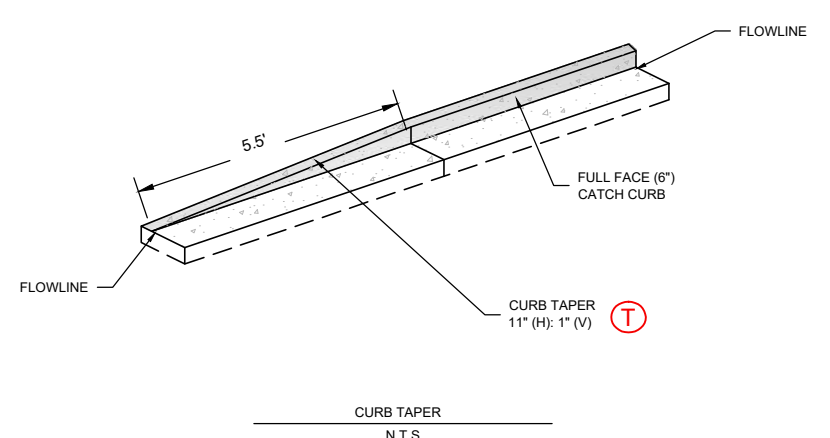

CURB TAPER
N.T.S.

CIVIL ENGINEERS | SURVEYORS
141 9th Street - P.O. Box 774843
Steamboat, Colorado 80477
(970) 871-9494
www.LANDMARK-CO.com

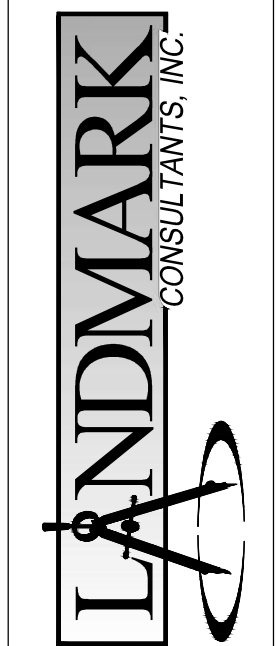

THESE DRAWINGS ARE INSTRUMENTS OF SERVICE provided by Landmark Consultants, Inc. and are not to be used for any construction or contracting unless signed and sealed by a duly licensed professional employee of Landmark Consultants, Inc.

NO.	DATE	BY	DESCRIPTION
PROJECT:	2387-04		
DATE:	1-28-22		
CONTACT:	GHF		
EMAIL:	eng@landmark-co.com		

Steamboat Basecamp - Phase I
Details (General)
SHEET
C.501

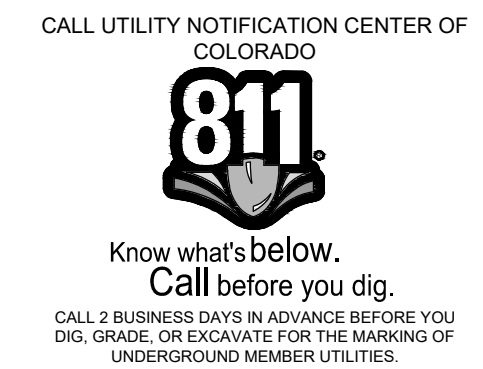

NOT VALID WITHOUT ORIGINAL SIGNATURE AND DATE

DRAWING FILENAME: P:\2387-04\Drawings\Phase I - Civil\2387-04-01-01-01-01-01.dwg, LAYOUT NAME: C501, DATE: Jan 28, 2022, 1:05pm, CAD: 09/10/2018, LIST OF SHEETS: (40/40)

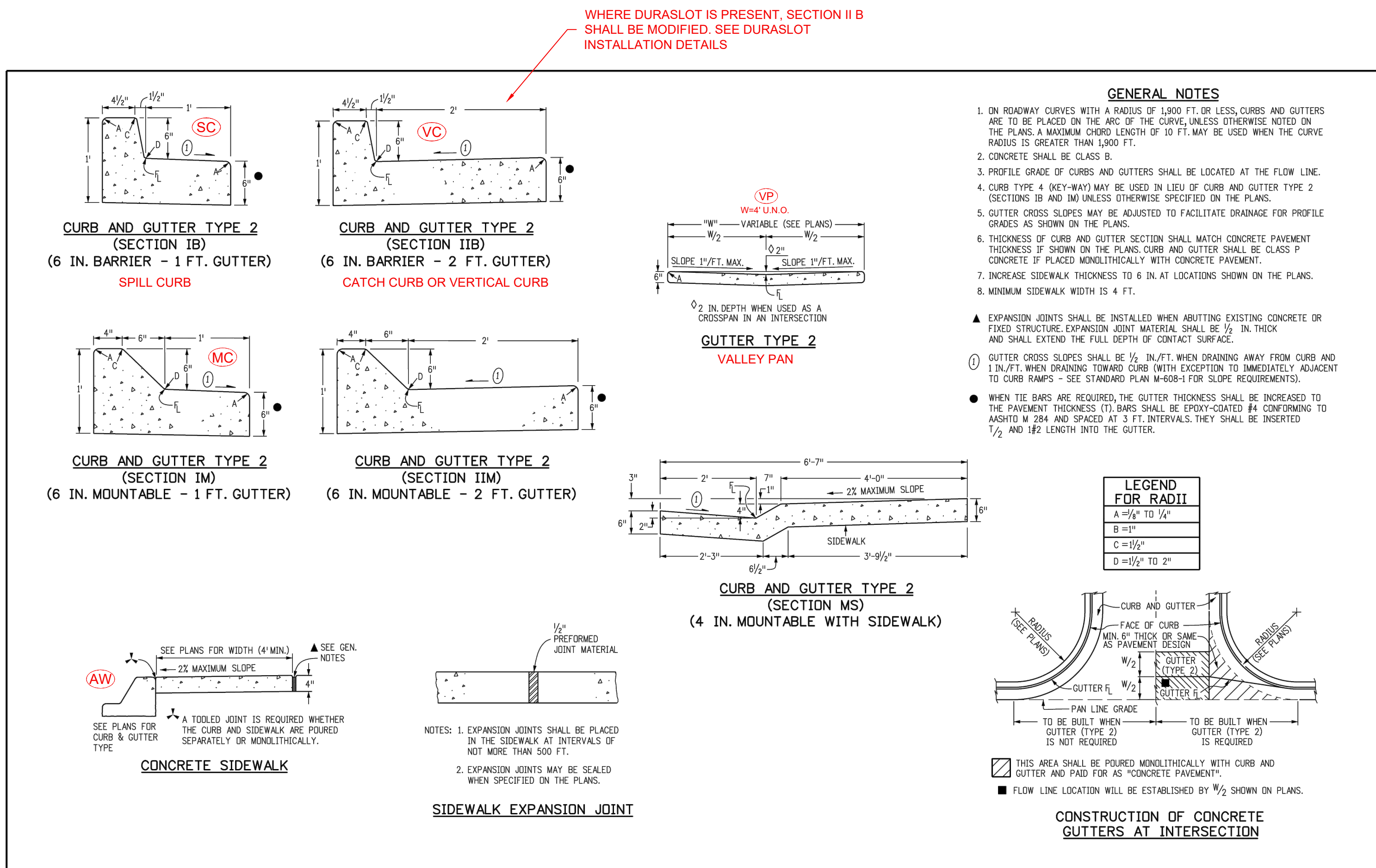

Computer File Information		Sheet Revisions		Colorado Department of Transportation		CURB, GUTTERS, AND SIDEWALKS		STANDARD PLAN NO.	
Creation Date: 07/04/12	Initials: DLM	Date:	Comments	4201 East Arkansas Avenue CDOT HQ, 4th Floor Denver, CO 80222 Phone: 303-757-9021 FAX: 303-757-9868		M-609-1		M-609-1	
Last Modification Date: 07/24/12	Initials: LTA	07/24/12	Changed the Bar spacing from 35" to 36"	Division of Project Support		DLM/LTA		Sheet No. 1 of 4	
Full Path: www.coloradodot.info/business/designsupport				Project Development Branch		Issued By: Project Development Branch on July 4, 2012			
Drawing File Name: B09010104.dgn				DLM/LTA					
CAD Ver: MicroStation V8	Scale: Not to Scale	Units: English							

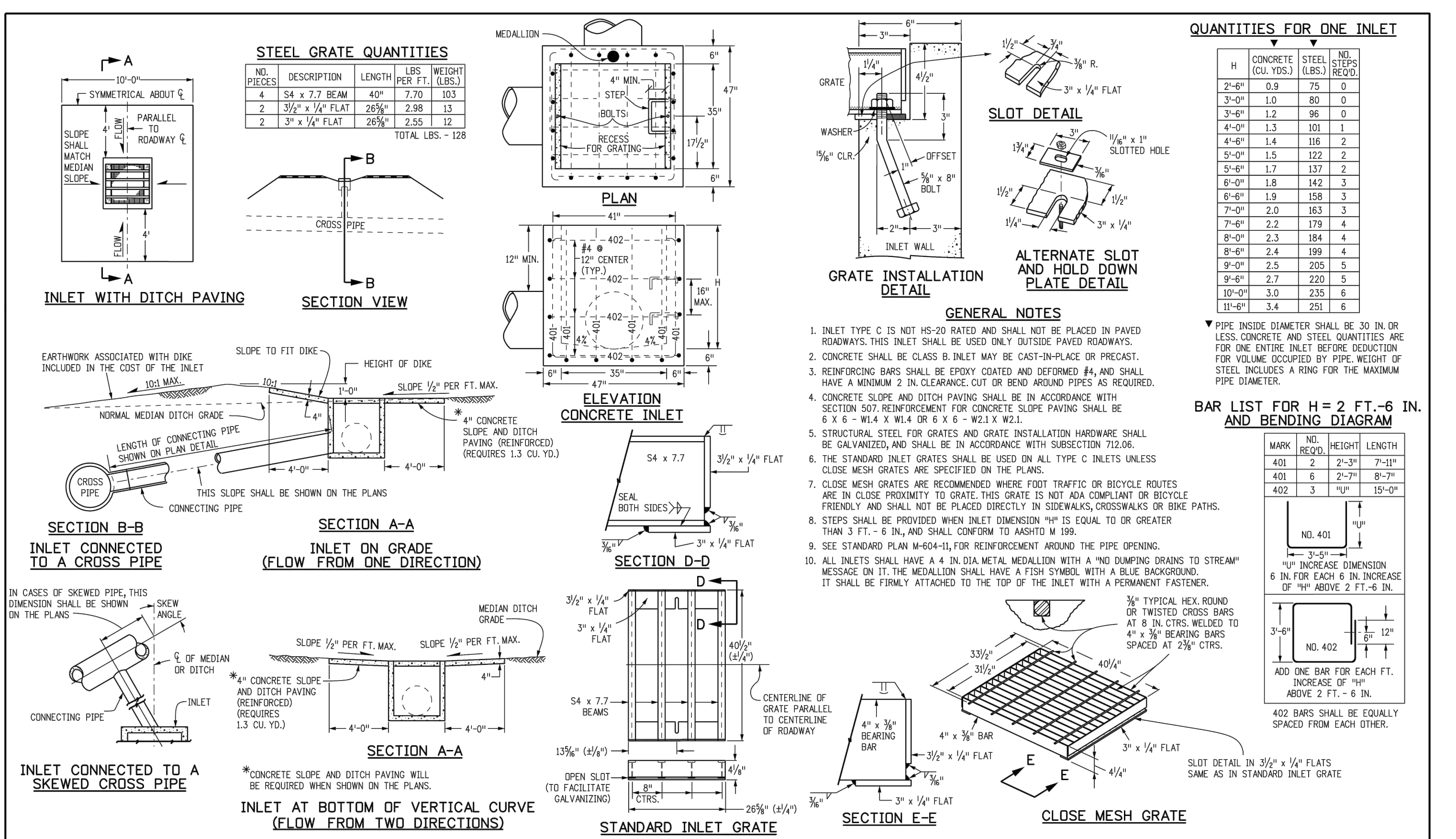

Computer File Information		Sheet Revisions		Colorado Department of Transportation		INLET, TYPE C		STANDARD PLAN NO.	
Creation Date: 07/04/12	Initials: DD	Date:	Comments	4201 East Arkansas Avenue Denver, Colorado 80222 Phone: (303) 757-9083 Fax: (303) 757-9820		M-604-10		M-604-10	
Last Modification Date: 07/04/12	Initials: LTA			Project Development Branch		DD/LTA		Sheet No. 1 of 1	
Full Path: www.coloradodot.info/business/designsupport				Project Development Branch		Issued By: Project Development Branch July 4, 2012			
Drawing File Name: 604010101.dgn									
CAD Ver: MicroStation V8	Scale: Not to Scale	Units: English							

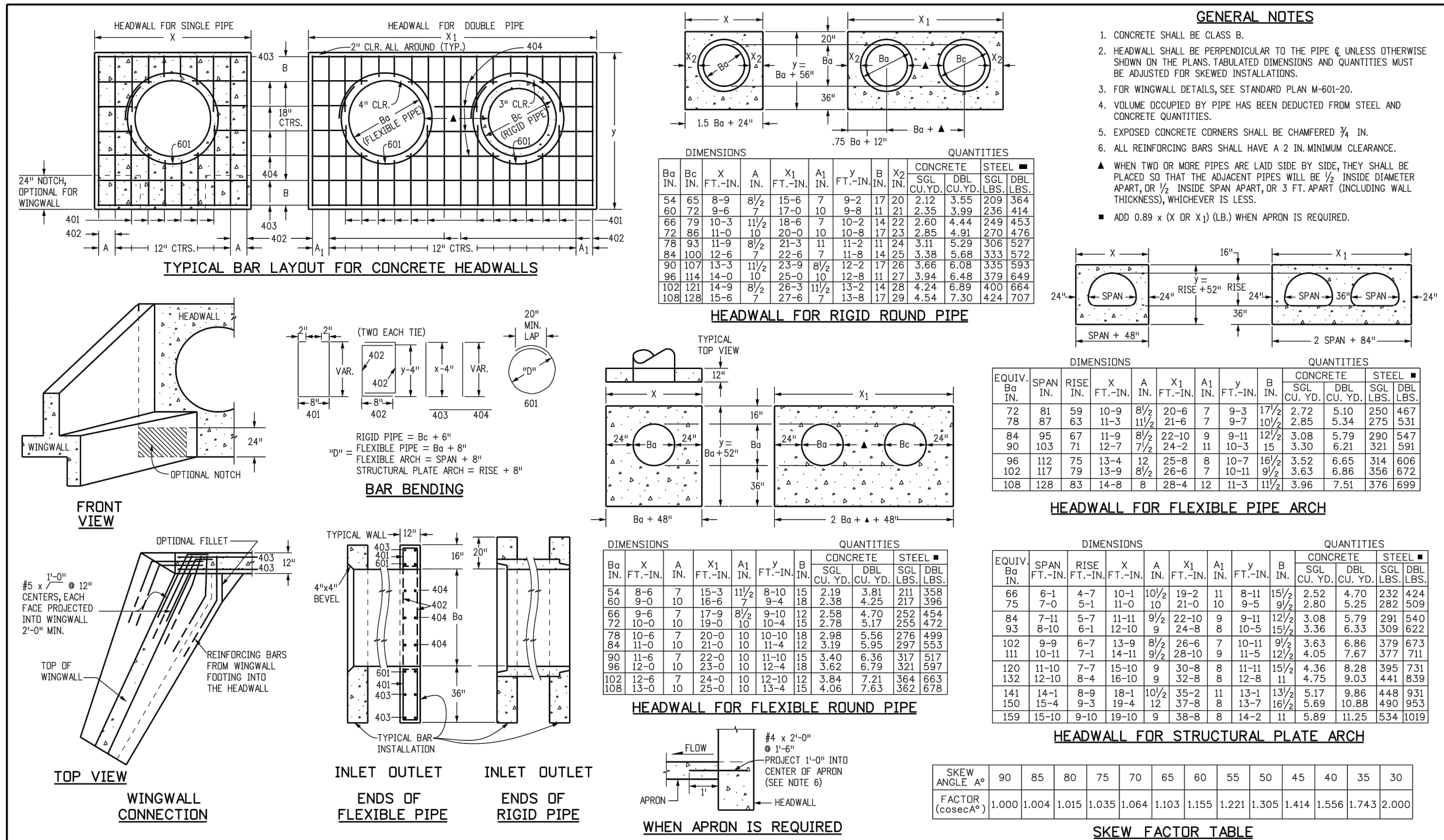

Computer File Information		Sheet Revisions		Colorado Department of Transportation		HEADWALL FOR PIPES		STANDARD PLAN NO.	
Creation Date: 07/31/19	Initials: JBK	Date:	Comments	2829 West Howard Place CDOT HQ, 3rd Floor Denver, CO 80204 Phone: 303-757-9021 FAX: 303-757-9868		M-601-10		Standard Sheet No. 1 of 1	
Last Modification Date: 07/31/19				Project Development Branch		JBK		Project Sheet Number:	
Designer Initials: JBK				Project Development Branch					
Detailed Initials: LTA									
CAD Ver: MicroStation V8	Scale: Not to Scale	Units: English							

CIVIL ENGINEERS | SURVEYORS
141 9th Street - P.O. Box 74843
Steamboat, Colorado 80477
(970) 871-9494
www.LANDMARK-CD.com

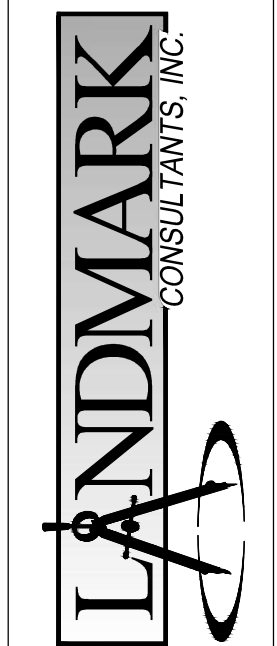

PLEASE ADVISE THE CLIENT OF ANY CHANGES TO THE CONTRACT DOCUMENTS provided by Landmark Consultants, Inc. and are not to be used for construction or contracting unless signed and sealed by a professional engineer or surveyor employed by Landmark Consultants, Inc.

NO.	DATE	BY:	DESCRIPTION

PROJECT:	2381-04
DATE:	1-28-22
CONTACT:	GJP
EMAIL:	eng@landmark-co.com

PROJECT:	2381-04
DATE:	1-28-22
CONTACT:	GJP
EMAIL:	eng@landmark-co.com

PROJECT:	2381-04
DATE:	1-28-22
CONTACT:	GJP
EMAIL:	eng@landmark-co.com

Steamboat Basecamp - Phase I
Details (CDOT)

CALL UTILITY NOTIFICATION CENTER OF COLORADO
811
Know what's below. Call before you dig.
CALL BUSINESS DAYS IN ADVANCE BEFORE YOU DIG, GRADE, OR EXCAVATE FOR THE MARKING OF UNDERGROUND MEMBER UTILITIES.

NOT VALID WITHOUT ORIGINAL SIGNATURE AND DATE



SHEET
C.505

CURB RAMP GENERAL NOTES:

- IN NEW CONSTRUCTION OR FULL-DEPTH RECONSTRUCTION, PROVIDE A SEPARATE CURB RAMP FOR EACH MARKED OR UNMARKED PEDESTRIAN STREET CROSSING. CURB RAMPS SHALL BE CONTAINED WHOLLY WITHIN THE WIDTH OF THE PEDESTRIAN STREET CROSSING OR CROSSWALK THEY SERVE, OR AS SHOWN ON THE CONTRACT PLANS.
- ALTERATIONS ARE DEFINED AS CHANGES TO AN EXISTING HIGHWAY THAT AFFECT PEDESTRIAN ACCESS, CIRCULATION, OR USE. ALTERATIONS INCLUDE, BUT ARE NOT LIMITED TO, RESURFACING, RECONSTRUCTION, CURB RAMP RETROFITS, HISTORIC RESTORATION, OR CHANGES OR REARRANGEMENT TO STRUCTURAL PARTS OR ELEMENTS OF A PEDESTRIAN FACILITY.
- A WALKABLE SURFACE IS DEFINED AS A PAVED SURFACE ADJACENT TO A CURB RAMP OR TURNING SPACE, WITHOUT RAISED OBSTACLES, THAT COULD BE MISTAKENLY TRAVERSED BY A USER WHO IS VISUALLY IMPAIRED.
- IN ALTERATIONS, WHERE AN EXISTING PHYSICAL CONSTRAINT PREVENTS PROVIDING A SEPARATE CURB RAMP FOR EACH PEDESTRIAN STREET CROSSING, A SINGLE DIAGONAL RAMP (ON THE APEX) SHALL BE PERMITTED TO SERVE BOTH PEDESTRIAN STREET CROSSINGS. THE USE OF A SINGLE DIAGONAL RAMP SHALL BE APPROVED BY THE ENGINEER PRIOR TO CONSTRUCTION. DIAGONAL RAMPS ARE NOT ACCEPTABLE IN NEW CONSTRUCTION OR FULL-DEPTH RECONSTRUCTION.
- DETECTABLE WARNING SURFACES (DWS) ARE INTENDED TO INDICATE THE BOUNDARY BETWEEN A PEDESTRIAN ROUTE AND VEHICULAR ROUTE WHERE THERE IS A FLUSH RAMP OR TURNING SPACE. DWS ARE NOT INTENDED TO PROVIDE WARNING. DWS SHALL BE PROVIDED AT THE FOLLOWING LOCATIONS:
 - CURB RAMPS, BLENDED TRANSITIONS, AND DEPRESSED CORNERS AT PEDESTRIAN STREET CROSSINGS;
 - PEDESTRIAN RETIERS (BLADES) 9 FEET IN WIDTH OR GREATER;
 - BOARDING PLATFORMS AT TRANSIT STOPS WHERE THE EDGE OF THE PLATFORM IS NOT PROTECTED TO PEDESTRIAN CROSS TRAFFIC; AND
 - BOARDING AREAS AT SIDEWALK OR STREET LEVEL TRANSIT STOPS WHERE THE AREA IS NOT PROTECTED TO PEDESTRIAN CROSS TRAFFIC.
- DETECTABLE WARNING SURFACES SHALL CONTRAST VISUALLY WITH THE ADJACENT GUTTER, HIGHWAY, OR PEDESTRIAN ACCESS ROUTE SURFACE, EITHER LIGHT-ON-DARK OR DARK-ON-LIGHT. FEDERAL YELLOW COLOR IS PREFERRED, HOWEVER, OTHER COLORS MAY BE USED IF APPROVED BY THE ENGINEER.
- IN ALTERATIONS, TO AVOID CHANGING GRADE INDEFINITELY ON STEEP ROADWAYS, A CURB RAMP LENGTH IS NOT REQUIRED TO EXCEED 15 FEET REGARDLESS OF THE RESULTING RAMP RUNNING SLOPE.
- ALL SLOPES ARE MEASURED WITH RESPECT TO A LEVEL PLANE.
- DRAINAGE STRUCTURES, TRAFFIC SIGNAL EQUIPMENT, OR OTHER OBSTRUCTIONS SHALL NOT BE INSTALLED ON THE CURB RAMP, OR TURNING SPACE AREAS.
- IN NEW CONSTRUCTION, PULL BOXES, METER BOXES, MAINTENANCE HOLE COVERS, VAULT LIDS, OR SIMILAR, SHALL NOT BE CONSTRUCTED WITHIN ANY PART OF CURB RAMP OR TURNING SPACE. IN ALTERATIONS, WHERE THESE ITEMS CANNOT BE RELOCATED OUTSIDE OF THE CURB RAMP OR TURNING SPACE, THEY MUST NOT CREATE A VERTICAL DISCONTINUITY GREATER THAN 1/2 INCH ANY VERTICAL DISCONTINUITY BETWEEN 1/4 INCH AND 1/2 INCH SHALL BE REVEALED WITH A SLOPE NOT STEEPER THAN 1:10. THE REVEAL SHALL BE APPLIED ACROSS THE ENTIRE SURFACE DISCONTINUITY.
- CONSTRUCTION OF ANY REQUIRED PEDESTRIAN CURB SHALL BE INCLUDED IN THE BID PRICE OF THE CONCRETE CURB RAMP AND WILL NOT BE PAID FOR SEPARATELY.
- ALL CURB RAMP JOINTS AND GRADE BREAKS SHALL BE FLUSH (0'-0" RISE). THE JOINT BETWEEN THE ROADWAY SURFACE AND THE GUTTER PAN SHALL BE FLUSH.
- THE CONTRACTOR SHALL VERIFY REMOVAL LIMITS ARE SUFFICIENT TO PROVIDE POSITIVE DRAINAGE, MAINTAIN EXISTING DRAINAGE PATTERNS, AND AVOID PONDING IN THE FINAL CONFIGURATION.
- FLARED SIDE SLOPES MAY EXCEED 10:0.0 ONLY WHERE THEY ABUT A NON-WALKABLE SURFACE, OR WHERE THE ADJACENT RAMP SURFACE IS BLOCKED TO PEDESTRIAN TRAFFIC.
- THE CHANGE IN GRADE AT THE BOTTOM OF THE CURB RAMP SHALL NOT EXCEED AN ALGEBRAIC DIFFERENCE OF 13.33% THE COUNTER SLOPE OF THE GUTTER AT THE FOOT OF A RAMP. TURNING SPACE, OR BLENDED TRANSITION SHALL NOT EXCEED 5:0.0.
- GRADE BREAKS AT THE TOP AND BOTTOM OF RAMP RUNS SHALL BE PERPENDICULAR TO THE DIRECTION OF THE RAMP RUN. GRADE BREAKS SHALL NOT BE PERMITTED ON THE SURFACE OF THE RAMP RUN OR TURNING SPACE. SURFACE SLOPES THAT MEET AT GRADE BREAKS SHALL BE FLUSH.
- A BROOM FINISH, WITH SWEEPS PERPENDICULAR TO THE DIRECTION OF PEDESTRIAN TRAFFIC, SHALL BE APPLIED TO ALL RAMP AND TURNING SPACE SURFACES.
- IN ALTERATIONS, WHERE A RAMP OR TURNING SPACE MUST FIT INTO AN EXISTING GRADE THAT CANNOT BE ALTERED, THE RAMP OR TURNING SPACE MAY BE WARPED TO TRANSITION TO THE REQUIRED CROSS SLOPE. THE TRANSITION TO THE REQUIRED CROSS SLOPE SHALL BE SPREAD EVENLY OVER THE LENGTH OF THE RAMP OR TURNING SPACE TO MINIMIZE THE DEGREE OF WARPING. THE RATE OF CHANGE ON A RAMP OR TURNING SPACE SHALL NOT EXCEED 3% PER LINEAR FOOT.
- DESIGN AND CONSTRUCT CURB RAMPS, TURNING SPACES, AND FLARE SLOPES WITH THE FLATTEST SLOPES POSSIBLE. THE SLOPES INDICATED IN THESE DETAILS SHOW THE MINIMUM SLOPES ALLOWABLE. PREFERRED VALUES TO BE USED DURING DESIGN, LAYOUT, AND CONSTRUCTION ARE:
 - RAMP RUNNING SLOPE 1:5
 - TURNING SPACE RUNNING SLOPE 1:5
 - TURNING SPACE CROSS SLOPE 1:5
 - FLARE SLOPE 8:0-9:0

- WHERE SNOW REMOVAL EQUIPMENT WILL BE USED TO CLEAR THE PEDESTRIAN ACCESS ROUTE, CONSULT THE ENGINEER PRIOR TO CONSTRUCTION TO ENSURE THE WIDTH AND THICKNESS OF CURB RAMPS IS SUFFICIENT TO ACCOMMODATE SUCH EQUIPMENT.
- PROVIDE EXPANSION JOINT MATERIAL 1/2" THICK WHERE CURB RAMPS ADJOIN ANY RIGID PAVEMENT OR STRUCTURE. THE TOP OF THE JOINT FILLER MATERIAL SHALL BE FLUSH WITH ADJACENT CONCRETE SURFACES. THE EXPANSION JOINT MATERIAL SHALL EXTEND FOR THE FULL DEPTH OF THE CONCRETE SURFACE.
- PROVIDE TIE BAR REINFORCING BETWEEN INDEPENDENTLY POURED CONCRETE CURB RAMPS OR TURNING SPACES AND CURB AND GUTTER. DRILL AND GROUT NO. 4 1/2 INCH LONG REINFORCING BARS (EPOXY COATED) AT 18 INCHES CENTER TO CENTER MINIMUM.

CURB RAMP PAY AREAS

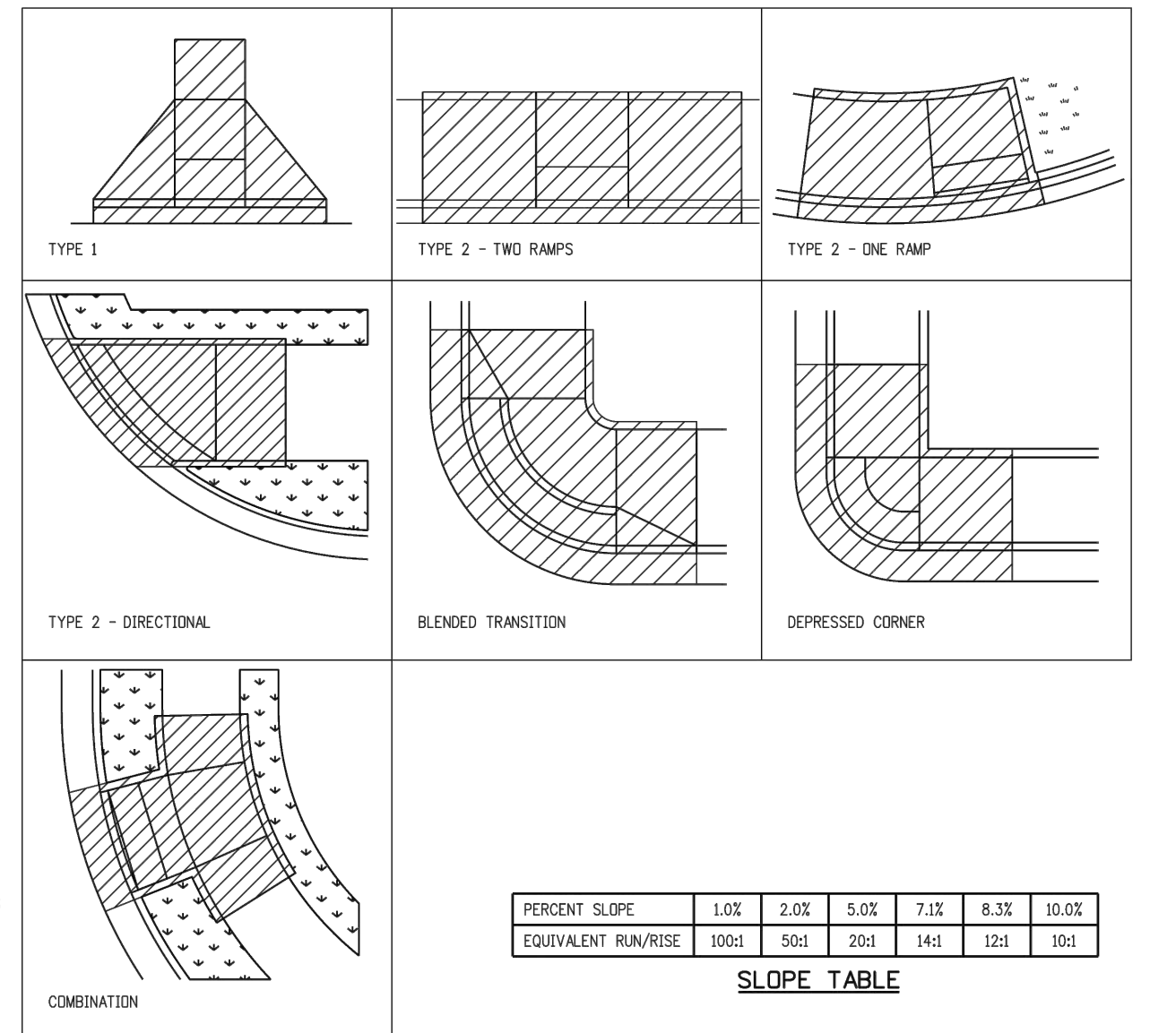

Computer File Information		Sheet Revisions	
Creation Date: 07/04/12	Initials: JBK	Date: 05/03/19	Comments: Completely revised every sheet.
Last Modification Date: 05/03/19	Initials: LTA		
Full Path: www.codot.gov/business/designsupport			
Drawing File Name: 6080104010.dgn			
CAD Ver: MicroStation V8	Scale: Not to Scale	Units: English	

Colorado Department of Transportation		STANDARD PLAN NO.	
2829 West Howard Place CDOT HO, 3rd Floor Denver, CO 80204 Phone: 303-757-9021 FAX: 303-757-9868	CURB RAMPS	M-608-1	
Division of Project Support JBK/LTA	Issued By: Project Development Branch July 4, 2012	Sheet No. 1 of 10	

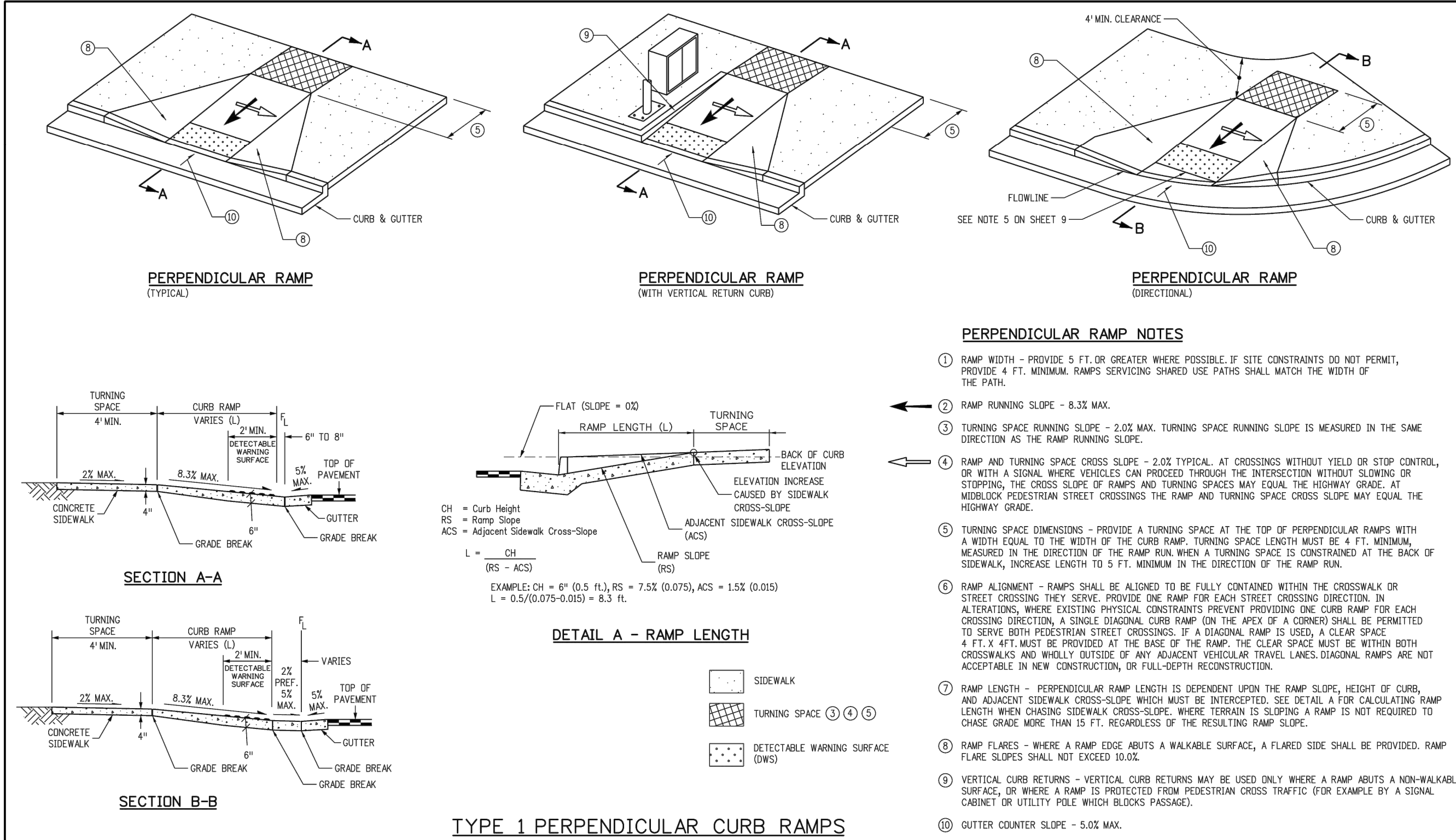

Computer File Information		Sheet Revisions	
Creation Date: 07/04/12	Initials: JBK	Date: 05/03/19	Comments: Completely revised every sheet.
Last Modification Date: 05/03/19	Initials: LTA		
Full Path: www.codot.gov/business/designsupport			
Drawing File Name: 6080104010.dgn			
CAD Ver: MicroStation V8	Scale: Not to Scale	Units: English	

Colorado Department of Transportation		STANDARD PLAN NO.	
2829 West Howard Place CDOT HO, 3rd Floor Denver, CO 80204 Phone: 303-757-9021 FAX: 303-757-9868	CURB RAMPS	M-608-1	
Division of Project Support JBK/LTA	Issued By: Project Development Branch July 4, 2012	Sheet No. 2 of 10	

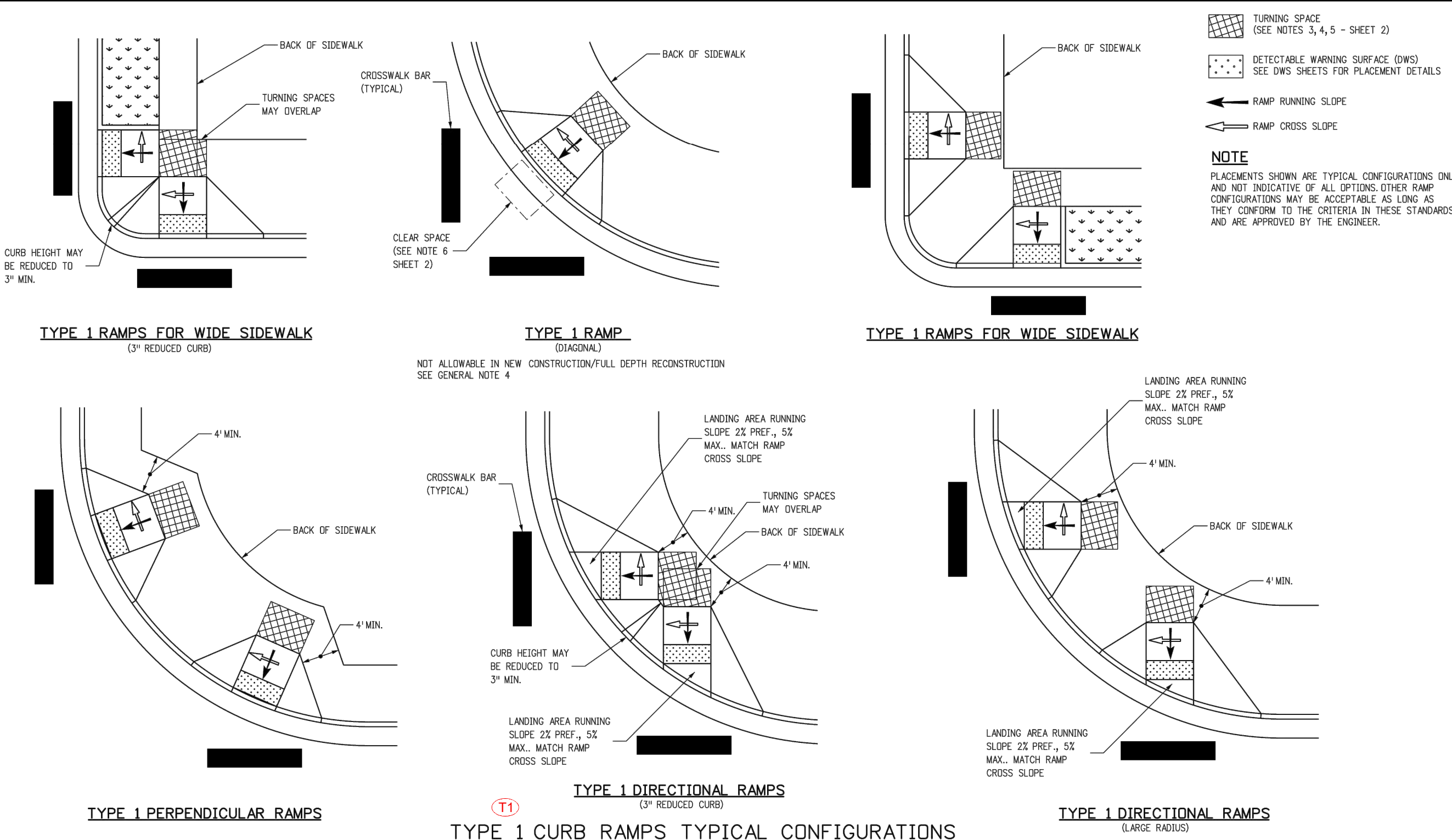

Computer File Information		Sheet Revisions	
Creation Date: 07/04/12	Initials: JBK	Date: 05/03/19	Comments: Completely revised every sheet.
Last Modification Date: 05/03/19	Initials: LTA		
Full Path: www.codot.gov/business/designsupport			
Drawing File Name: 6080104010.dgn			
CAD Ver: MicroStation V8	Scale: Not to Scale	Units: English	

Colorado Department of Transportation		STANDARD PLAN NO.	
2829 West Howard Place CDOT HO, 3rd Floor Denver, CO 80204 Phone: 303-757-9021 FAX: 303-757-9868	CURB RAMPS	M-608-1	
Division of Project Support JBK/LTA	Issued By: Project Development Branch July 4, 2012	Sheet No. 3 of 10	

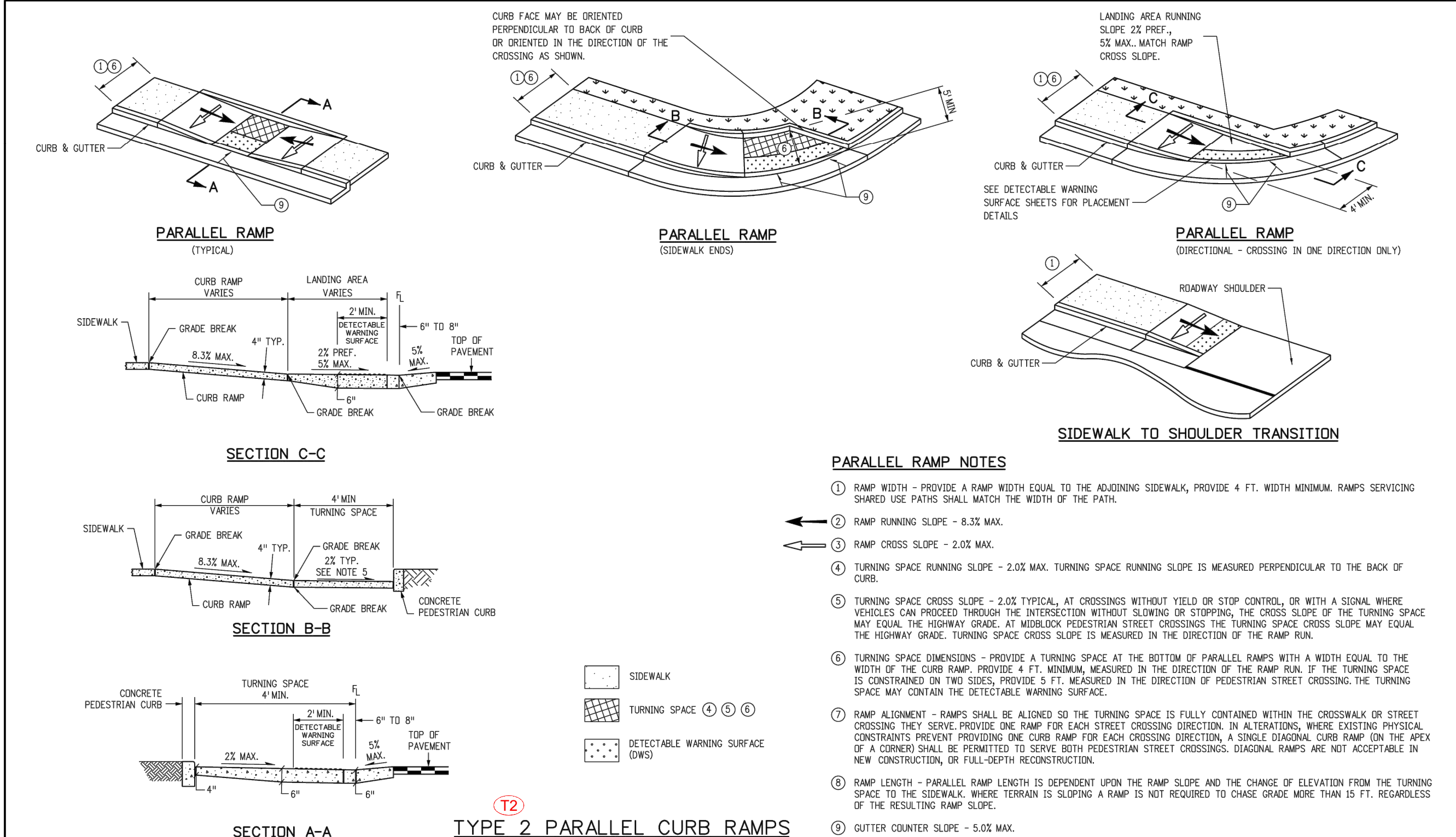

Computer File Information		Sheet Revisions	
Creation Date: 07/04/12	Initials: JBK	Date: 05/03/19	Comments: Completely revised every sheet.
Last Modification Date: 05/03/19	Initials: LTA		
Full Path: www.codot.gov/business/designsupport			
Drawing File Name: 6080104010.dgn			
CAD Ver: MicroStation V8	Scale: Not to Scale	Units: English	

Colorado Department of Transportation		STANDARD PLAN NO.	
2829 West Howard Place CDOT HO, 3rd Floor Denver, CO 80204 Phone: 303-757-9021 FAX: 303-757-9868	CURB RAMPS	M-608-1	
Division of Project Support JBK/LTA	Issued By: Project Development Branch July 4, 2012	Sheet No. 4 of 10	

CIVIL ENGINEERS | SURVEYORS
141 9th Street - P.O. Box 774843
Steamboat, Colorado 80477
(970) 871-9494
www.LANDMARK-CD.com

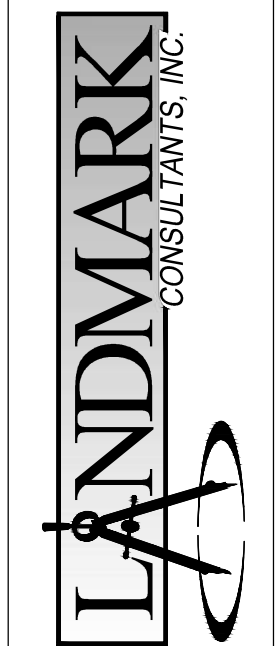

PLEASE PRINTING AND INSTRUMENT SERVICE provided by Landmark Consultants, Inc. and are not construction or contracting unless signed and sealed by a professional engineer or surveyor employed by Landmark Consultants, Inc.

NO.	DATE:	DESCRIPTION:

PROJECT:	2387-04
DATE:	1-28-22
CONTACT:	GJP
EMAIL:	eng@landmark-co.com

Computer File Information		Sheet Revisions	
Creation Date: 07/04/12	Initials: JBK	Date: 05/03/19	Comments: Completely revised every sheet.
Last Modification Date: 05/03/19	Initials: LTA		
Full Path: www.codot.gov/business/designsupport			
Drawing File Name: 6080104010.dgn			
CAD Ver: MicroStation V8	Scale: Not to Scale	Units: English	

Colorado Department of Transportation		STANDARD PLAN NO.	
2829 West Howard Place CDOT HO, 3rd Floor Denver, CO 80204 Phone: 303-757-9021 FAX: 303-757-9868	CURB RAMPS	M-608-1	
Division of Project Support JBK/LTA	Issued By: Project Development Branch July 4, 2012	Sheet No. 4 of 10	

Steamboat Basecamp - Phase I
Details (CDOT)

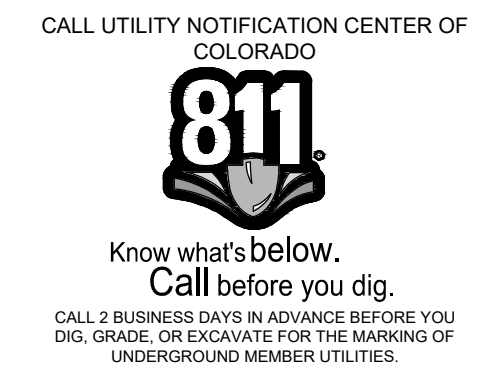

SHEET
C.506
NOT VALID WITHOUT ORIGINAL SIGNATURE AND DATE

ADS DURASLOT® PIPE SPECIFICATION

Scope
This specification describes 4- through 36-inch (100 to 900 mm) ADS DURASLOT pipe for use in surface drain applications.

- Pipe Requirements**
DURASLOT pipe, as manufactured and distributed by ADS, Inc., shall have a smooth interior and annular exterior corrugations with an aluminum slot grate frame mounted longitudinally along the length of the pipe to accept the grate while maintaining the original pipe diameter.
- 4- through 10-inch (100 to 250mm) pipe shall meet AASHTO M252, Type S.
 - 12- through 36-inch (300 to 900 mm) pipe shall meet AASHTO M294, Type S or ASTM F2306.
 - Manning's "n" value for use in design shall be 0.012.

The aluminum slot grate frame shall be manufactured from 0.063" tempered commercial aluminum meeting the requirements of ASTM B209, consisting of two parallel plates separated by spacers spanning the slot on 6" centers. The grate shall be 1/2" - #13 galvanized steel. The grate shall have a diamond-shaped opening and be ADA compliant. The flange at the bottom of the aluminum slot grate frame shall be riveted to the pipe with a minimum of two rivets per linear foot.

Fittings
DURASLOT fittings shall be modified from fittings which conform to AASHTO M252, AASHTO M294, or ASTM F2306.

Installation
Installation shall be in accordance with ADS recommended installation instructions. Contact your local ADS representative or visit www.ads-pipe.com for a copy of the latest installation guidelines.

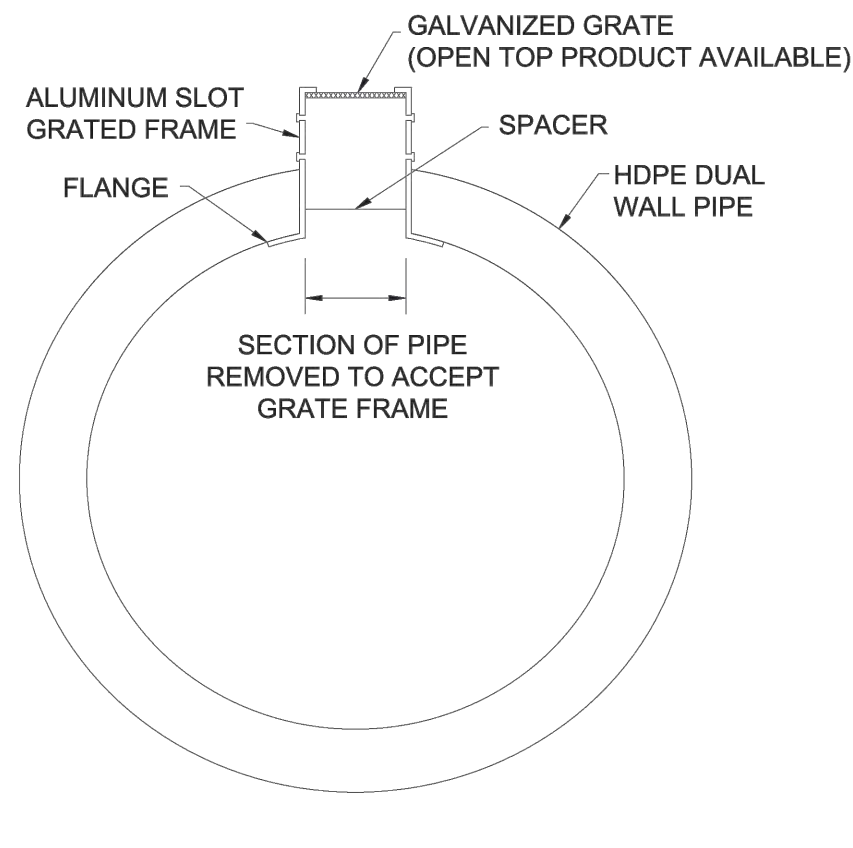

© ADS, Inc., November 2017

6"-24" DURASLOT® Pipe Dimensions For Variable Slot Riser

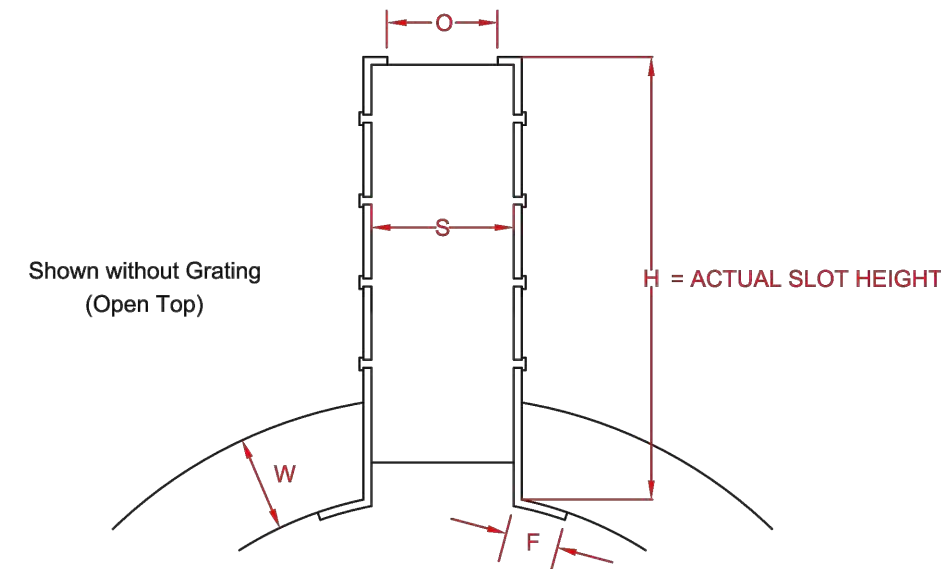

PIPE DIAM.	PIPE WALL (W)	FLANGE WIDTH (F)	SLOT OPENING (O)	THROAT SIZE (S)	SLOT HEIGHT (H)	PRODUCT # (Grated)	PRODUCT # (Open Top)
6" (150mm)	0.8" (19mm)	0.75" (19mm)	1.75" (44mm)	2.25" (57mm)	Varies*	0690DS	0690DSOT
8" (200mm)	0.625" (16mm)	0.75" (19mm)	1.75" (44mm)	2.25" (57mm)	Varies*	0890DS	0890DSOT
10" (250mm)	0.75" (19mm)	0.75" (19mm)	1.75" (44mm)	2.25" (57mm)	Varies*	1090DS	1090DSOT
12" (300mm)	1.125" (29mm)	0.75" (19mm)	1.75" (44mm)	2.25" (57mm)	Varies*	1290DS	1290DSOT
15" (375mm)	1.25" (32mm)	0.75" (19mm)	1.75" (44mm)	2.25" (57mm)	Varies*	1590DS	1590DSOT
18" (450mm)	1.25" (32mm)	0.75" (19mm)	1.75" (44mm)	2.25" (57mm)	Varies*	1890DS	1890DSOT
24" (600mm)	1.875" (48mm)	1.0" (25mm)	1.75" (44mm)	2.25" (57mm)	Varies*	2490DS	2490DSOT

NOTE: Slot Heights to conform to dimensions on project plans. *H at ends of each length of DURASLOT® to be detailed on Slot Dimensions Layouts for approval before production.

REV	DESCRIPTION	BY	MM/DD/YY	CHKD
1	1 OF 1			

DRAWING NUMBER: 460 TRUESMAN BLVD HELLAND, OHIO 43028

6"-24" DURASLOT® Pipe With Variable Slot Riser

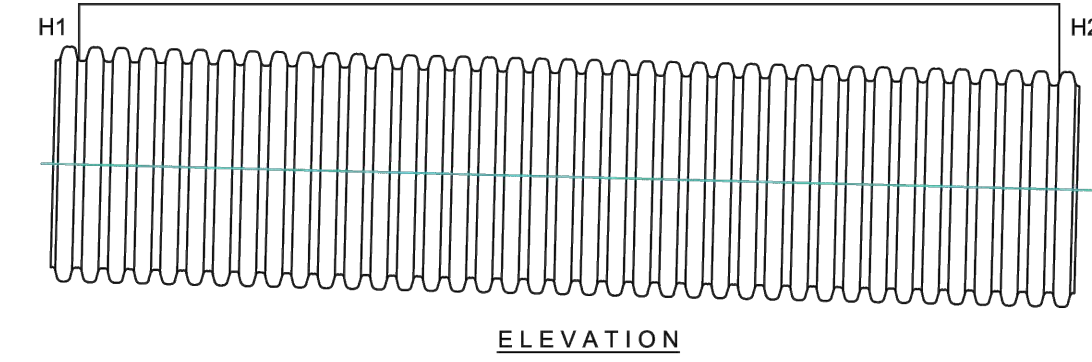
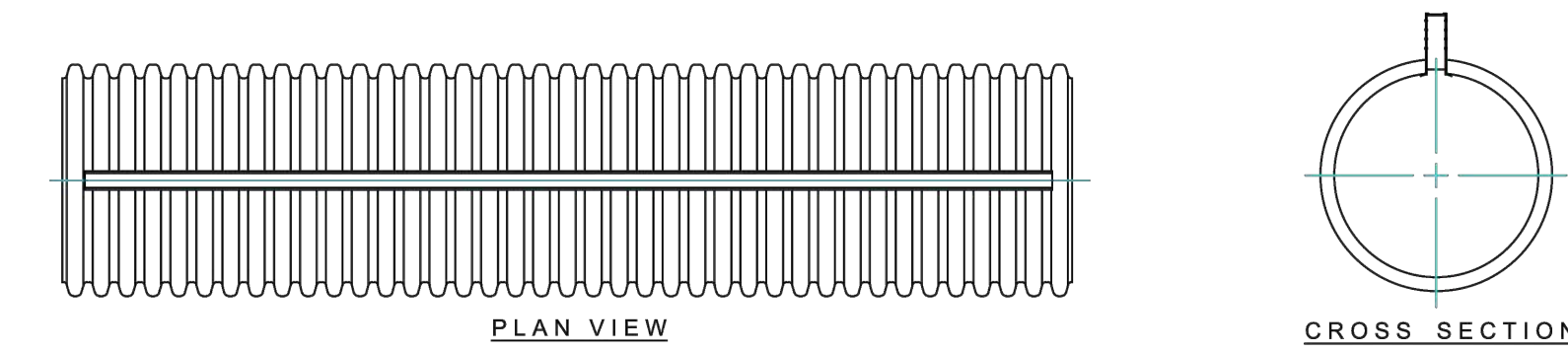

NOTE: H1 and H2 vary based on project specifications.

PIPE DIAM.	PRODUCT # (GRATED)	PRODUCT # (OPEN TOP)
6" (150mm)	0690DS	0690DSOT
8" (200mm)	0890DS	0890DSOT
10" (250mm)	1090DS	1090DSOT
12" (300mm)	1290DS	1290DSOT
15" (375mm)	1590DS	1590DSOT
18" (450mm)	1890DS	1890DSOT
24" (600mm)	2490DS	2490DSOT

REV	DESCRIPTION	BY	MM/DD/YY	CHKD
1	1 OF 1			

DRAWING NUMBER: 460 TRUESMAN BLVD HELLAND, OHIO 43028

6"-24" DURASLOT® Coupler Bands With Variable Slot Riser

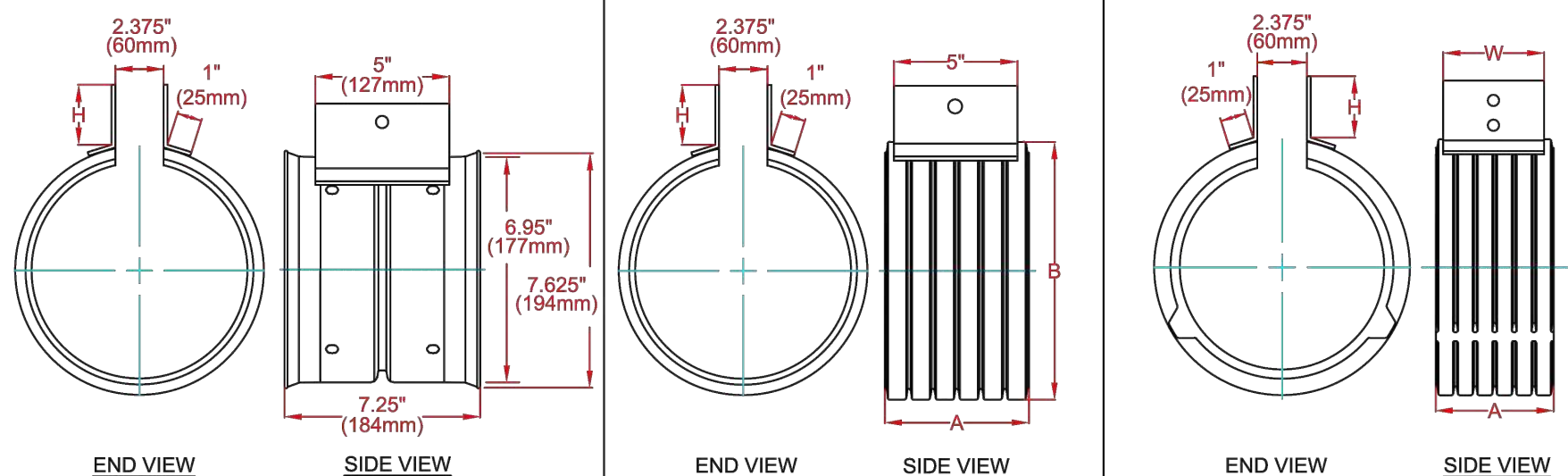

PIPE DIAM.	H	PRODUCT #
6" (150mm)	Varies	0691DS

PIPE DIAM.	H	B	A	PRODUCT #
8" (200mm)	Varies	10" (254mm)	150mm (150mm)	0891DS
10" (250mm)	Varies	12.5" (318mm)	5" (140mm)	1091DS

PIPE DIAM.	H	W	A	PRODUCT #
12" (300mm)	Varies	8" (200mm)	7.75" (197mm)	1291DS
15" (375mm)	Varies	9" (229mm)	10.5" (267mm)	1591DS
18" (450mm)	Varies	9" (229mm)	10.5" (267mm)	1891DS
24" (600mm)	Varies	10" (250mm)	12.63" (321mm)	2491DS

NOTE: ALL DIMENSIONS ARE FOR REFERENCE ONLY

DRAWING #	DESIGN BY	APPROVED BY	REVISIONS	SCALE
			NTS	

6"-24" DURASLOT® Adapter With Variable Slot Riser

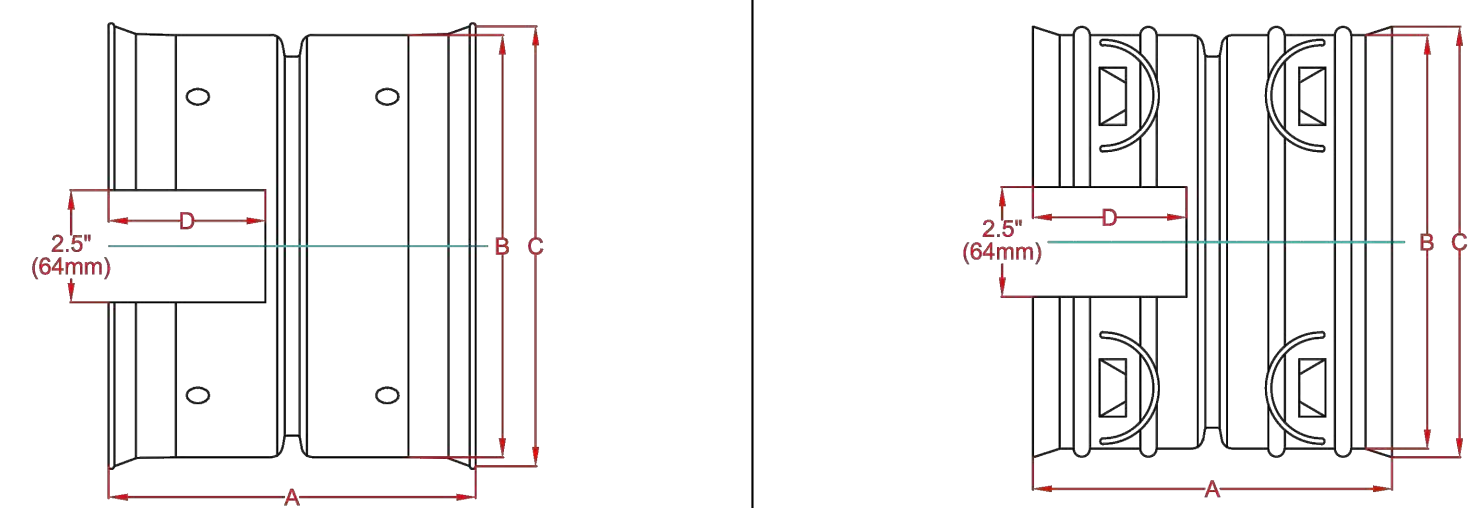

PIPE DIAM.	A	B	C	D	PRODUCT #
12" (300mm)	7.25" (184mm)	6.95" (177mm)	7.63" (194mm)	3" (76mm)	0662DS
8" (200mm)	8.25" (210mm)	9.17" (233mm)	10.13" (257mm)	3.5" (89mm)	0862DS
10" (250mm)	9.25" (235mm)	11.56" (294mm)	12.13" (308mm)	4" (100mm)	1062DS

PIPE DIAM.	A	B	C	D	PRODUCT #
12" (300mm)	14" (356mm)	14.6" (371mm)	15.4" (391mm)	5.5" (140mm)	1262DS
15" (375mm)	16" (406mm)	17.75" (449mm)	18.6" (472mm)	6.5" (165mm)	1562DS
18" (450mm)	18" (450mm)	21.4" (544mm)	22.4" (569mm)	7.5" (191mm)	1862DS
24" (600mm)	14.8" (373mm)	28.2" (716mm)	29.25" (743mm)	6" (150mm)	2462DS

NOTE: ACCEPTABLE ALTERNATE FOR THIS PART

NOTE: ALL DIMENSIONS ARE FOR REFERENCE ONLY

DRAWING #	DESIGN BY	APPROVED BY	REVISIONS	SCALE
			NTS	

ADS DURASLOT® STANDARD DIMENSIONS

	Nominal Pipe Diameter in (mm)									
	4"(100)	6"(150)	8"(200)	10"(250)	12"(300)	15"(375)	18"(450)	24"(600)	30"(750)	36"(900)
L (Drain Grate Length)	116" (2950)									
E (Pipe End Length)	1" (25)									
W (2.5" slot)	2.75" (70)	3" (75)	3" (75)	3" (75)	3.5" (90)	3.75" (95)	4" (100)	4.75" (120)	5" (125)	5.25" (130)
H (6.0" slot)	6.25" (160)	6.5" (165)	6.5" (165)	6.5" (165)	7" (175)	7" (175)	7" (175)	7.25" (185)	8.25" (210)	8.25" (210)
W (Pipe Width w/ Corrugation)	0.34" (9)	0.46" (12)	0.61" (15)	0.73" (18)	1.15" (30)	1.30" (33)	1.57" (40)	1.86" (47)	2.50" (65)	2.85" (72)
F (Flange Length)	0.5" (13)	0.75" (19)	0.75" (19)	0.75" (19)	0.75" (19)	0.75" (19)	1.0" (25)	1.5" (38)	1.5" (38)	1.5" (38)
O (Opening Width)	1.25" (32)	1.75" (45)	1.75" (45)	1.75" (45)	1.75" (45)	1.75" (45)	1.75" (45)	1.75" (45)	1.75" (45)	1.75" (45)
S (Slot Width)	1.75" (45)	2.25" (57)	2.25" (57)	2.25" (57)	2.25" (57)	2.25" (57)	2.25" (57)	2.25" (57)	2.25" (57)	2.25" (57)

- Note:**
- Variable and custom slot heights upon request. Production of variable and custom slots will require approval by engineering services and fabrication. Signed shop drawings also required from interested party.
 - Other grate material options upon request. Contact local ADS representative for availability of grate material option.

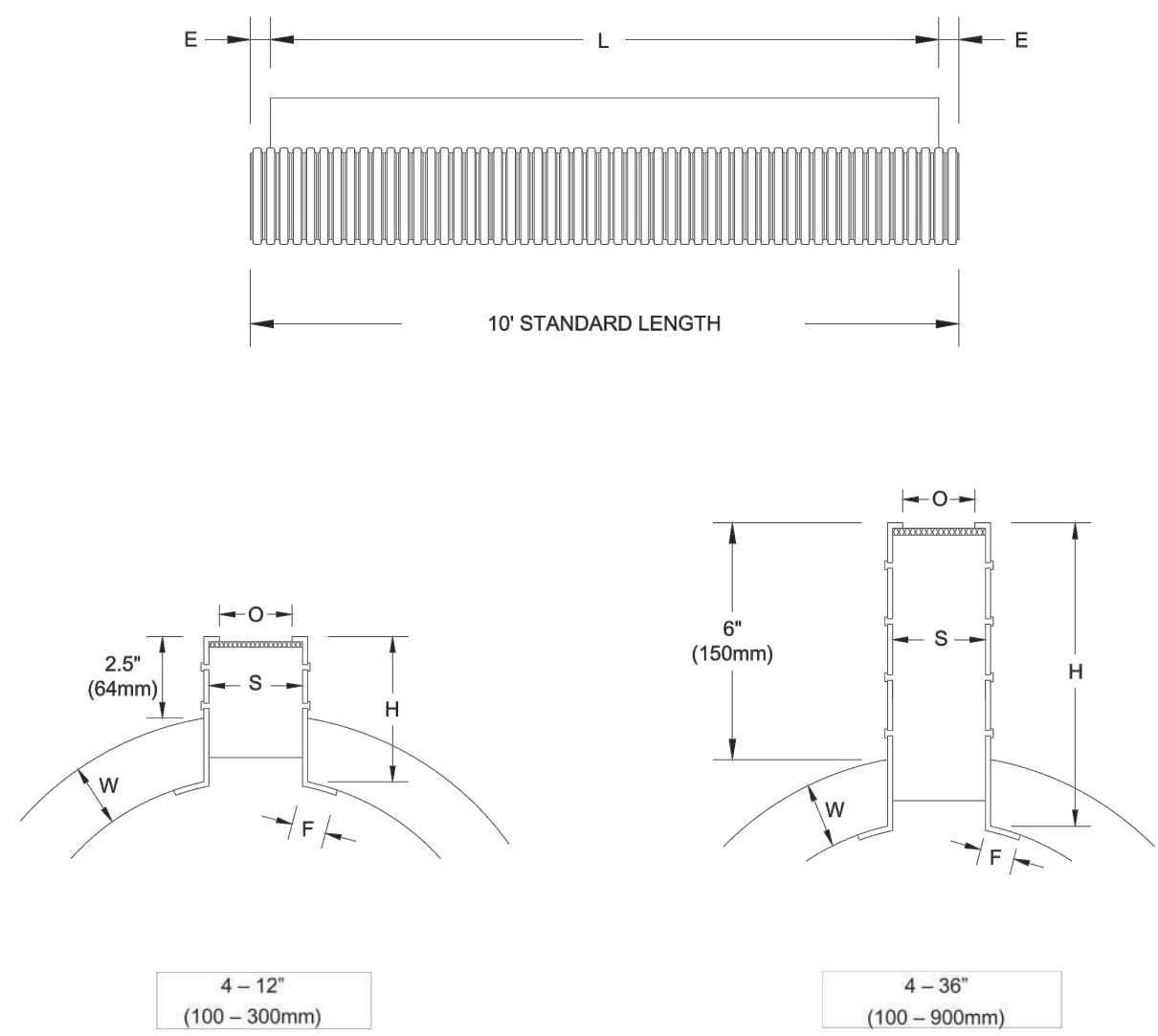

© ADS, Inc., November 2017

6"-24" DURASLOT® End Cap With Variable Slot Riser

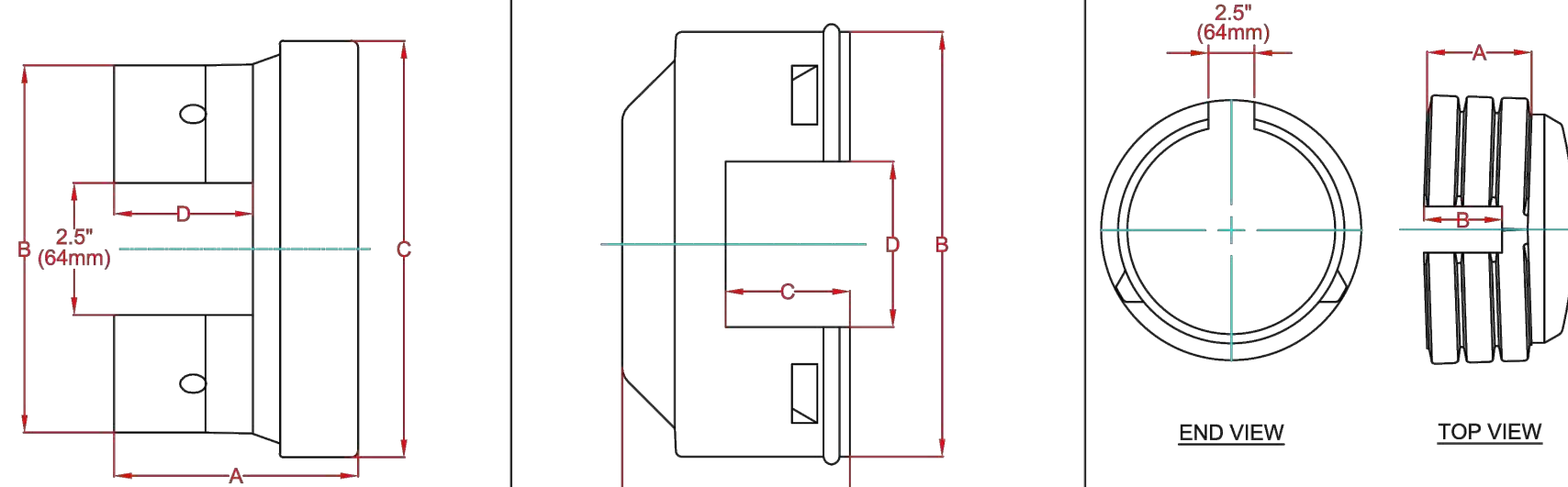

PIPE DIAM.	A	B	C	D	PRODUCT #
6" (150mm)	4.5" (114mm)	6.95" (177mm)	7.63" (194mm)	3" (76mm)	0633DS
10" (250mm)	5" (127mm)	11.56" (294mm)	12.13" (308mm)	3.5" (89mm)	1033DS

PIPE DIAM.	A	B	C	D	PRODUCT #
8" (200mm)	4.25" (108mm)	9.875" (248mm)	2.5" (64mm)	2.5" (64mm)	0833DS

PIPE DIAM.	A	B	PRODUCT #
12" (300mm)	5.76" (146mm)	4.25" (108mm)	1233DS
15" (375mm)	7.77" (197mm)	6.25" (159mm)	1533DS
18" (450mm)	8.04" (204mm)	6.50" (165mm)	1833DS
24" (600mm)	9.45" (240mm)	8" (200mm)	2433DS

NOTE: ALL DIMENSIONS ARE FOR REFERENCE ONLY

DRAWING #	DESIGN BY	APPROVED BY	REVISIONS	SCALE
			NTS	

6"-24" DURASLOT® System Assembly With Variable Slot Riser - Grated

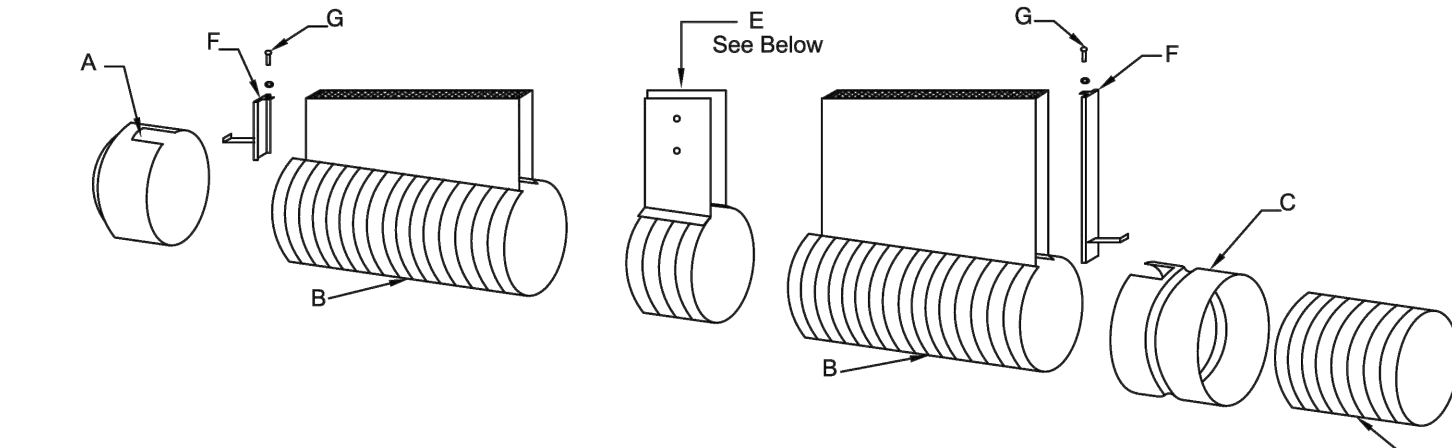

- A. DURASLOT End Cap
- B. DURASLOT Pipe
- C. DURASLOT Adapter
- D. N-12 Pipe
- E. DURASLOT Coupler Band
- F. DURASLOT Grate Anchor
- G. 1/2" SPHS x 1" Long w/ Washer
- H. DURASLOT Grate Connector
- I. 3/8" Hex Head Screw x 3/2" Long w/ Washer & 3/8" Wingnut
- J. Plastic Sleeve Spacer (Goes on L. - Not used w/ 4" DIAM.)
- K. Hex Head Assembly
- L. 3/8" Hex Head Screw x 3/2" Long w/ (2) Washers and 3/8" Hex Nut

NOTE: Each Cap (A) & Adapter (C) comes with an Anchor (F). Each Coupler Band (E) comes with Hardware - I, J, K, & L.

REV	DESCRIPTION	BY	MM/DD/YY	CHKD
1	1 OF 1			

DRAWING NUMBER: 460 TRUESMAN BLVD HELLAND, OHIO 43028

CALL UTILITY NOTIFICATION CENTER OF COLORADO



Know what's Below. Call before you dig.



NOT VALID WITHOUT ORIGINAL SIGNATURE AND DATE

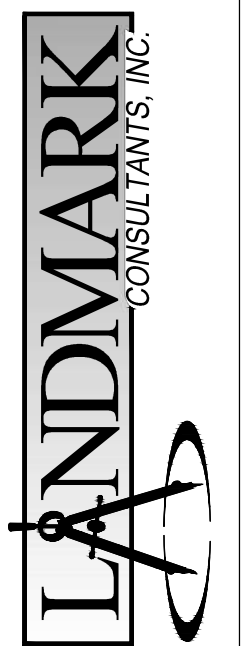

THESE PROFESSIONAL SERVICES are provided by Landmark Consultants, Inc. and are not to be used for any other construction or contracting project unless signed and sealed by a professional engineer or surveyor employed by Landmark Consultants, Inc.

NO.	DESCRIPTION	DATE	BY
2397-04	1-28-22		

PROJECT: 2397-04
DATE: 1-28-22
CONTACT: GJP
EMAIL: enrg@landmark-co.com

DRAWING FILENAME: P:\2023\04\2397-04\PH1\23-C-510-Detailed.dwg PLOT DATE: 01/28/2023 11:29:04 AM PLOTTER: HP DesignJet T1200

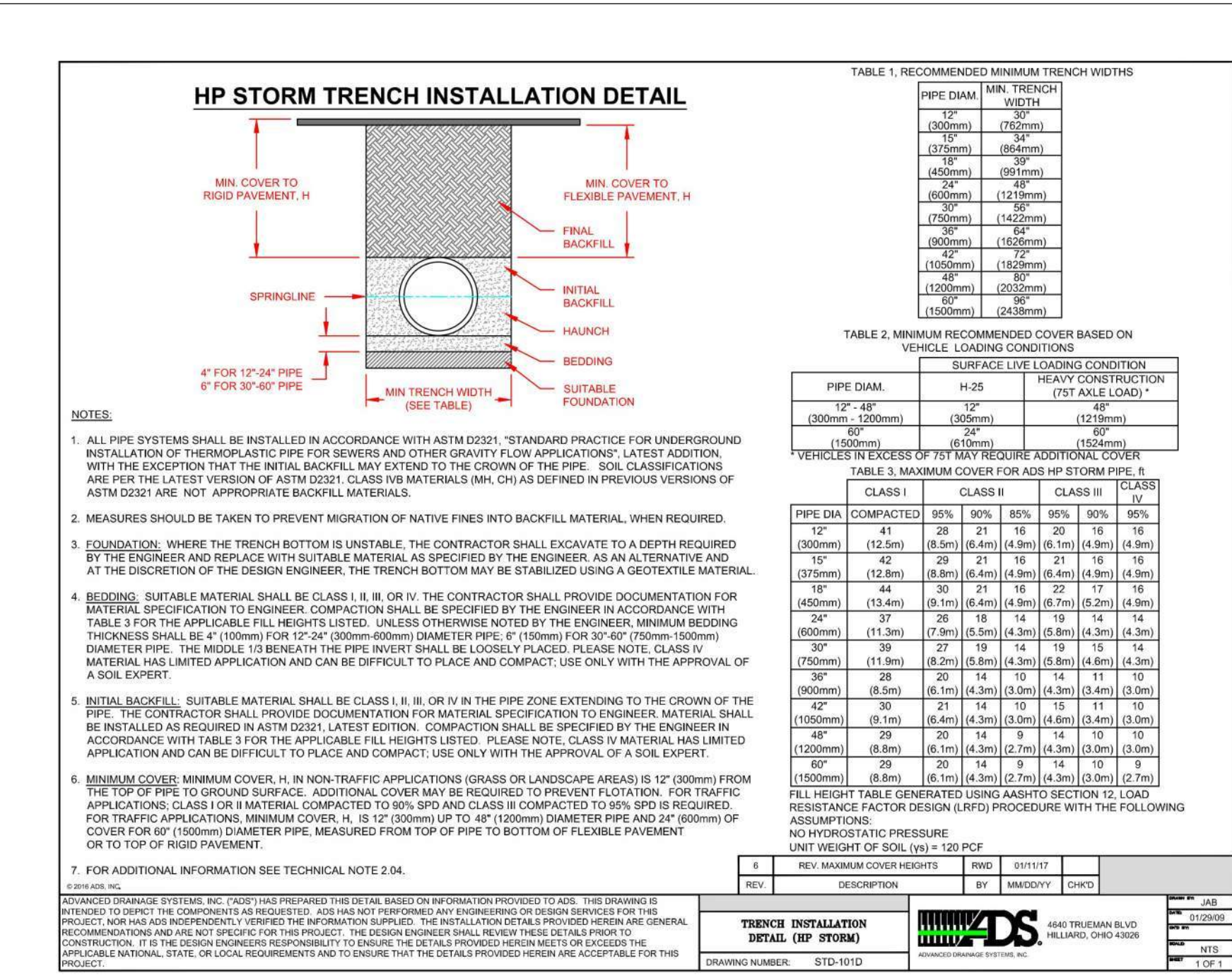
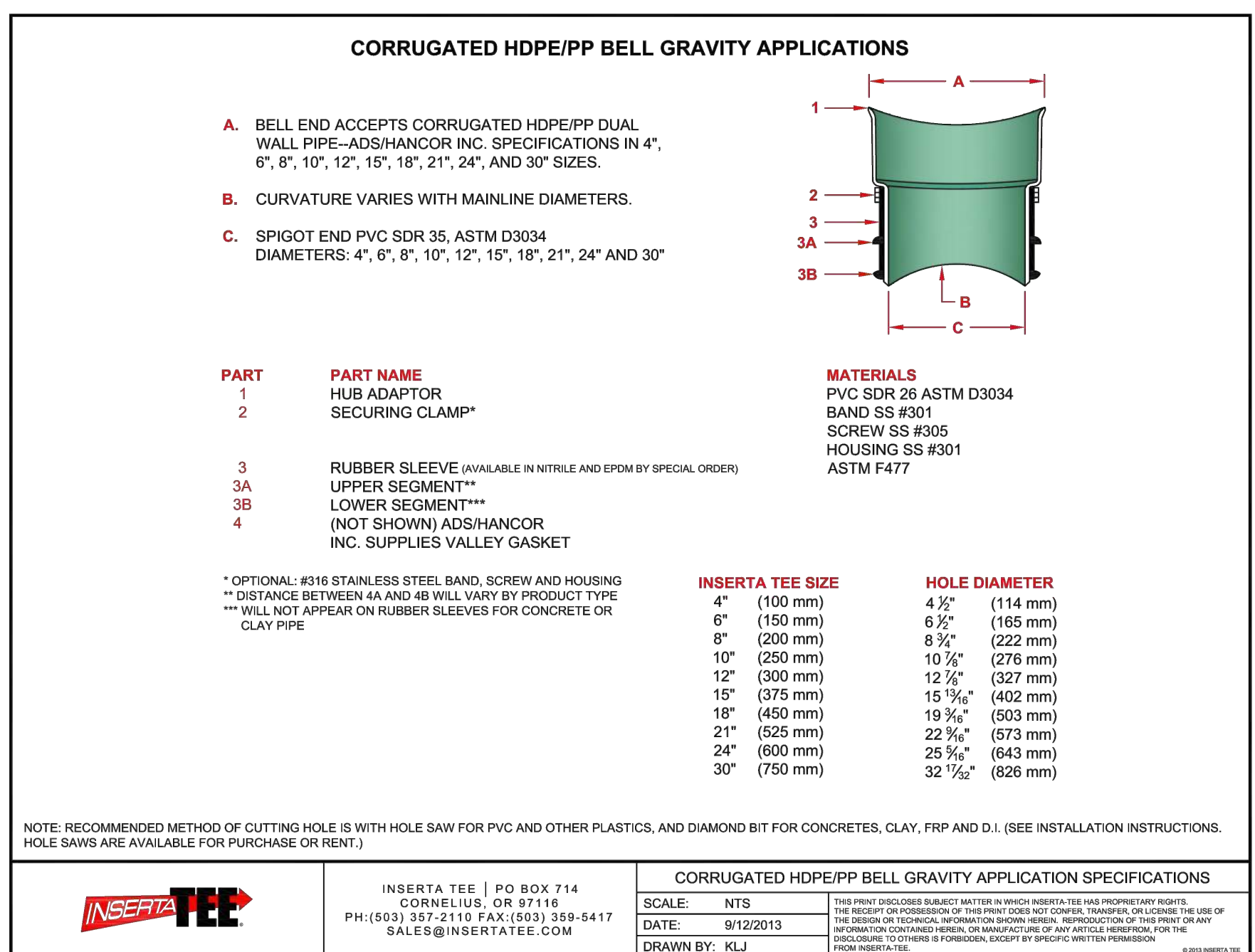
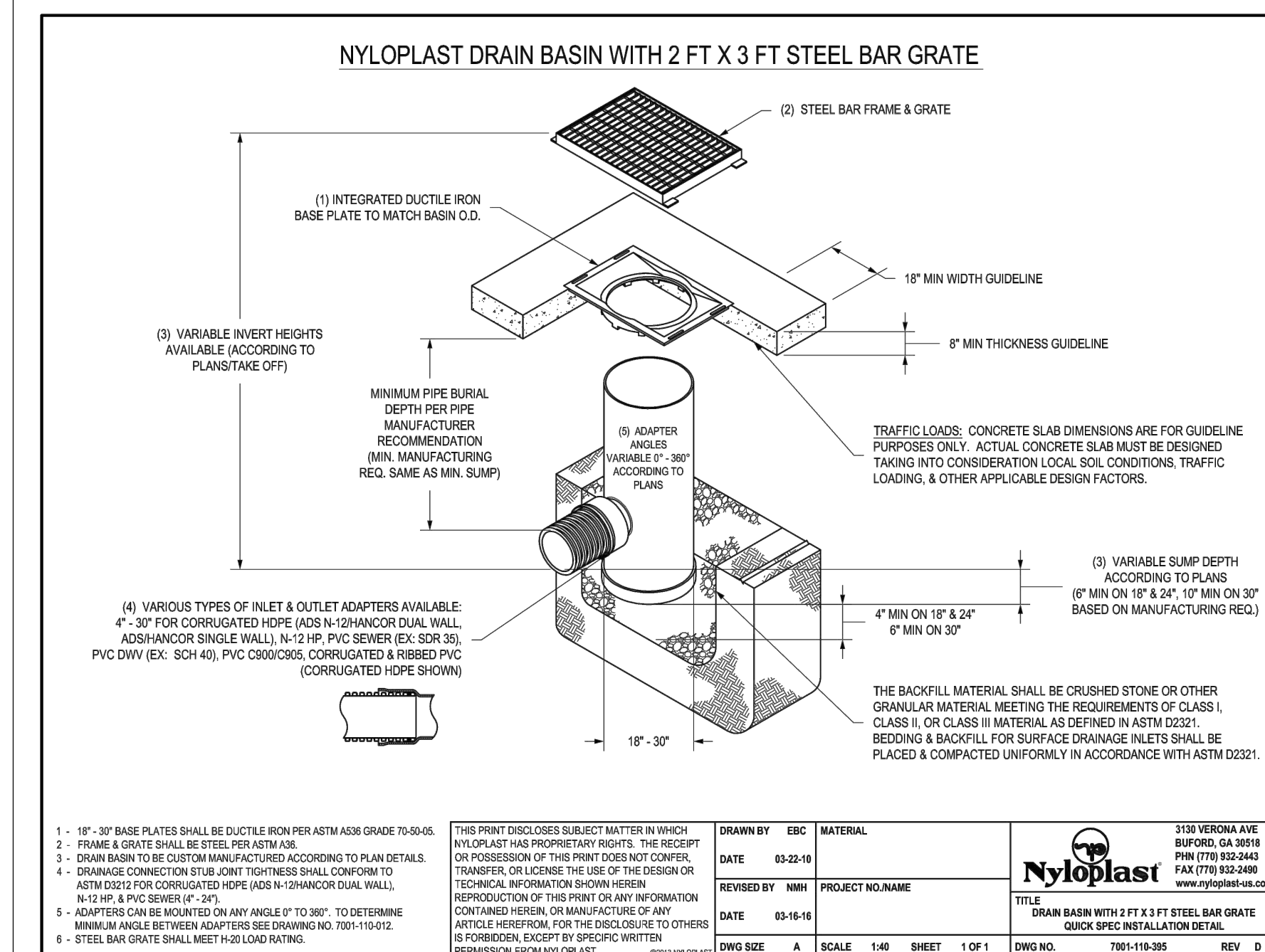
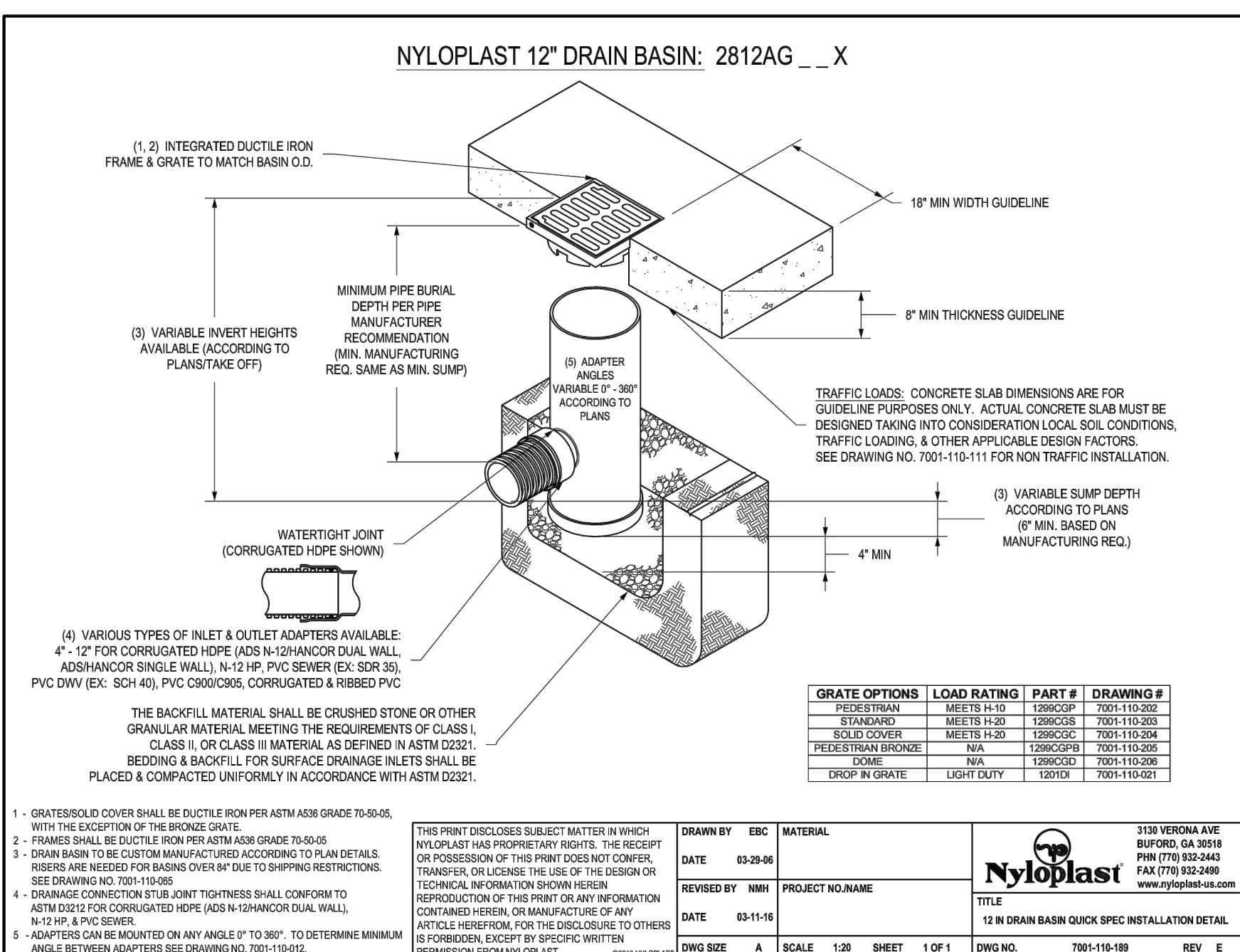
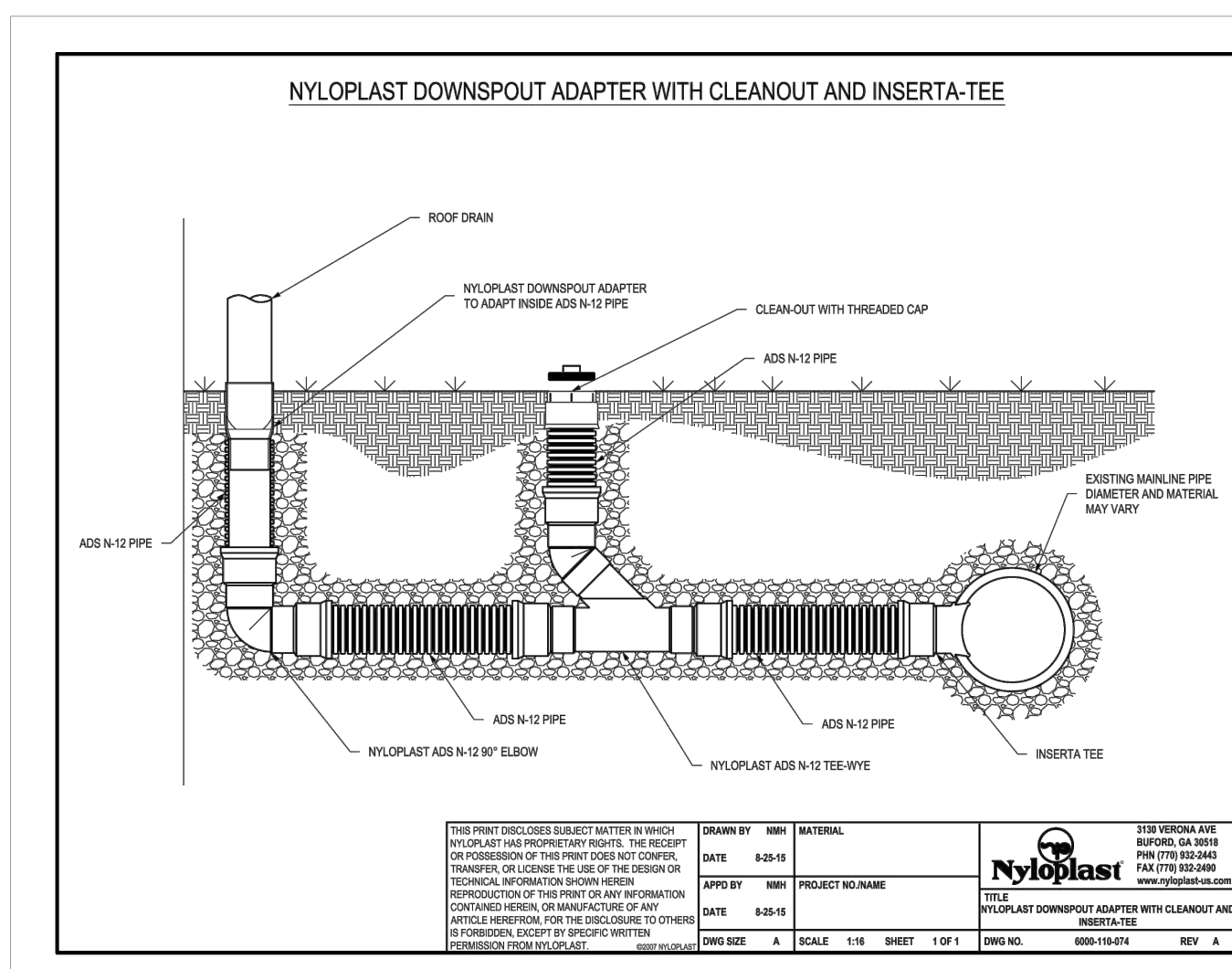
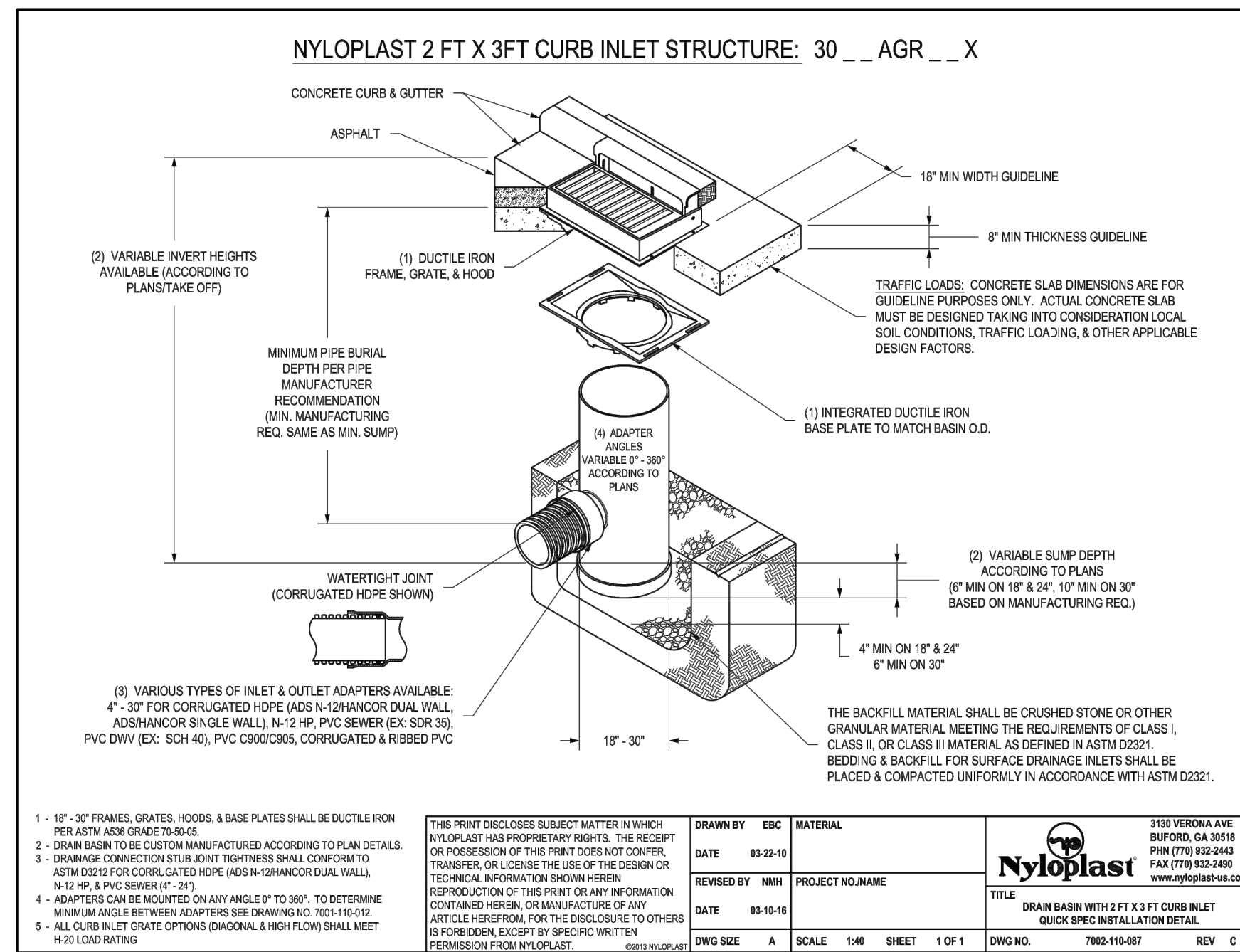
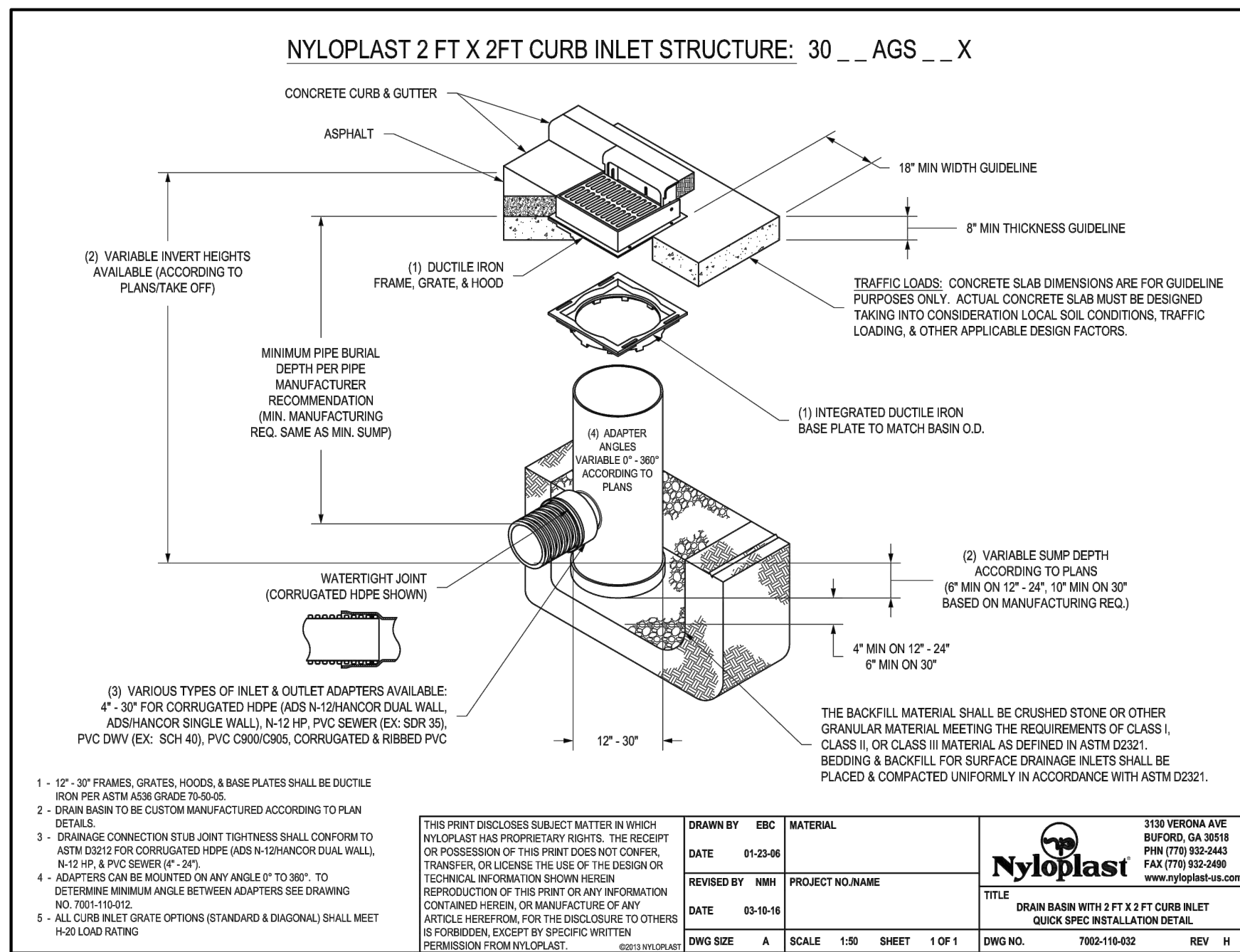

STEAMBOAT BASECAMP OWNERSHIP AND MAINTENANCE (O&M) PLAN FOR EXTENDED DETENTION BASIN

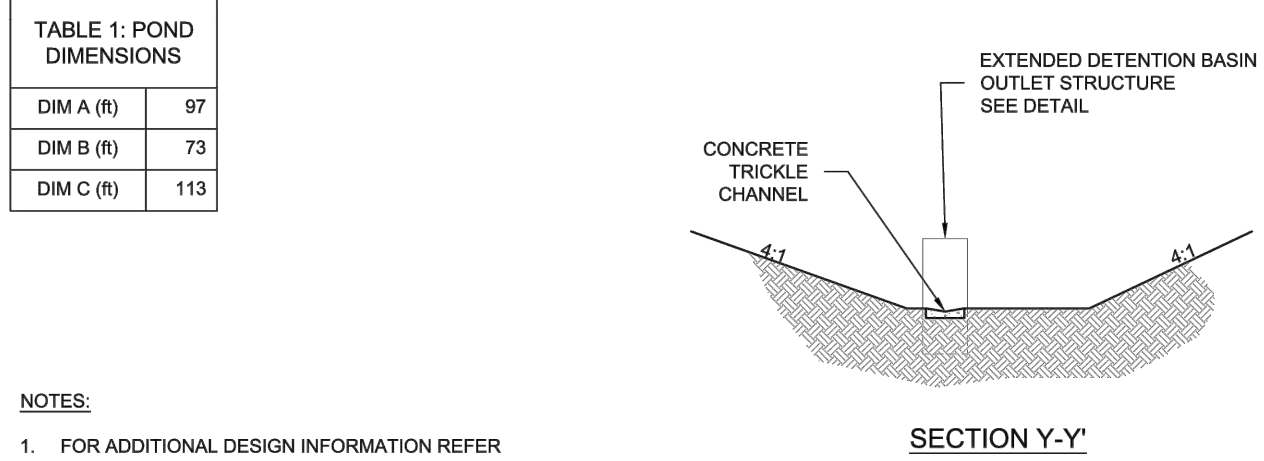
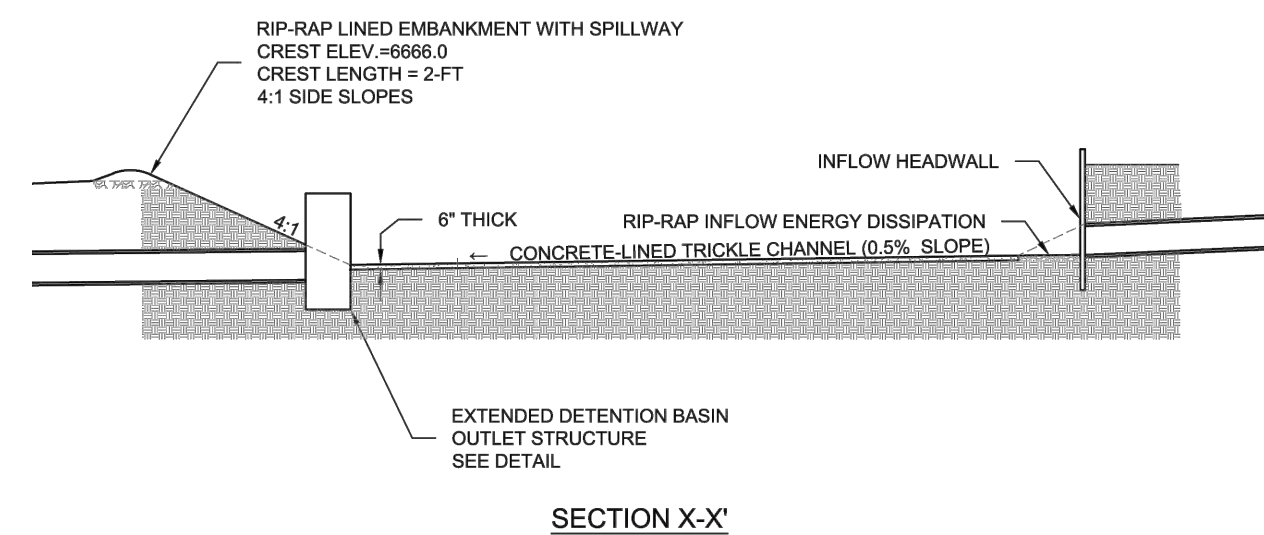
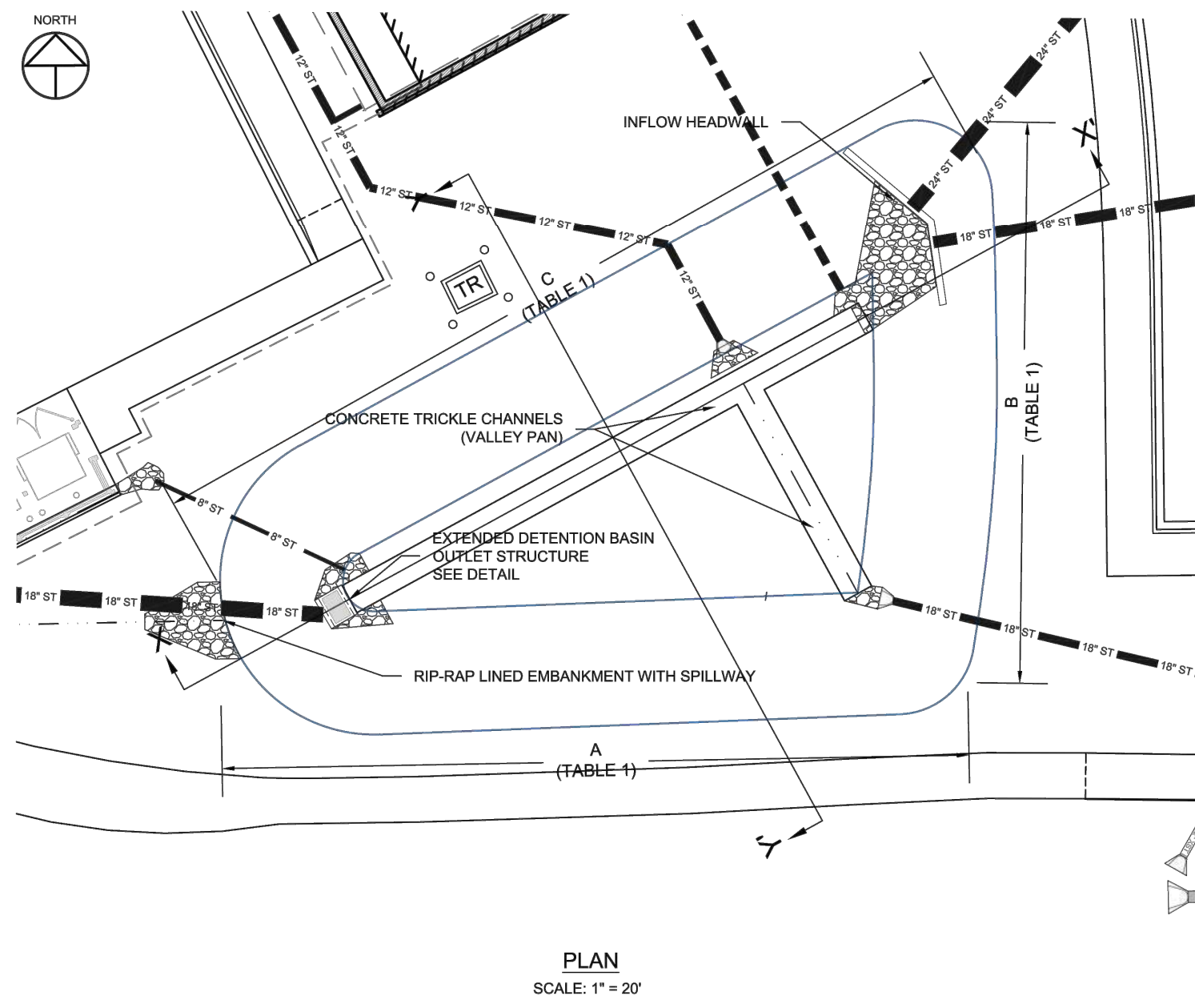
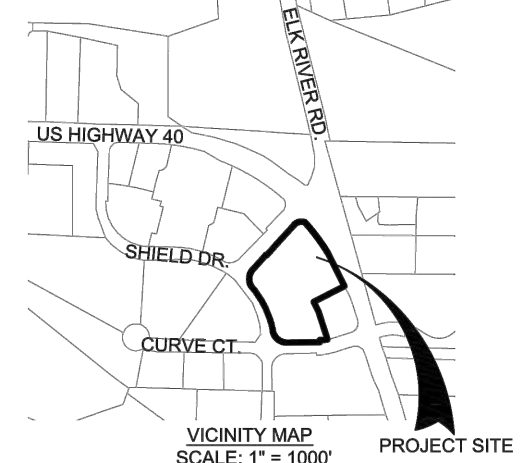

TABLE 1: POND DIMENSIONS

DIM A (ft)	97
DIM B (ft)	73
DIM C (ft)	113

- NOTES:
- FOR ADDITIONAL DESIGN INFORMATION REFER TO THE CONSTRUCTION DRAWINGS FOR THIS PROJECT.
 - DISTURBANCE OF WETLAND AREAS SHALL BE AVOIDED DURING MAINTENANCE OPERATIONS.
 - SEE DETAILED NOTES ON THE THIRD SHEET OF THIS PLAN FOR ALL MAINTENANCE REQUIREMENTS.



PROJECT: 2387-004	NO. 1	DATE: 12-23-21	BY: DS	DESCRIPTION: DRT Comments
DRAWN BY: DCS				
CHECKED BY: LCI				

These drawings are instruments of service provided by Landmark Consultants, Inc. and are not to be used for any type of construction or contracting unless signed and sealed by a Professional Engineer in the employ of Landmark Consultants, Inc.



CIVIL ENGINEERS | SURVEYORS
141 9th Street - P.O. Box 774943
Steamboat Springs, Colorado 80477
(970) 871-9494 www.LANDMARK-CO.com

Steamboat Basecamp
Ownership & Maintenance Plan
Extended Detention Basin

SHEET
1
Of 3 Sheets

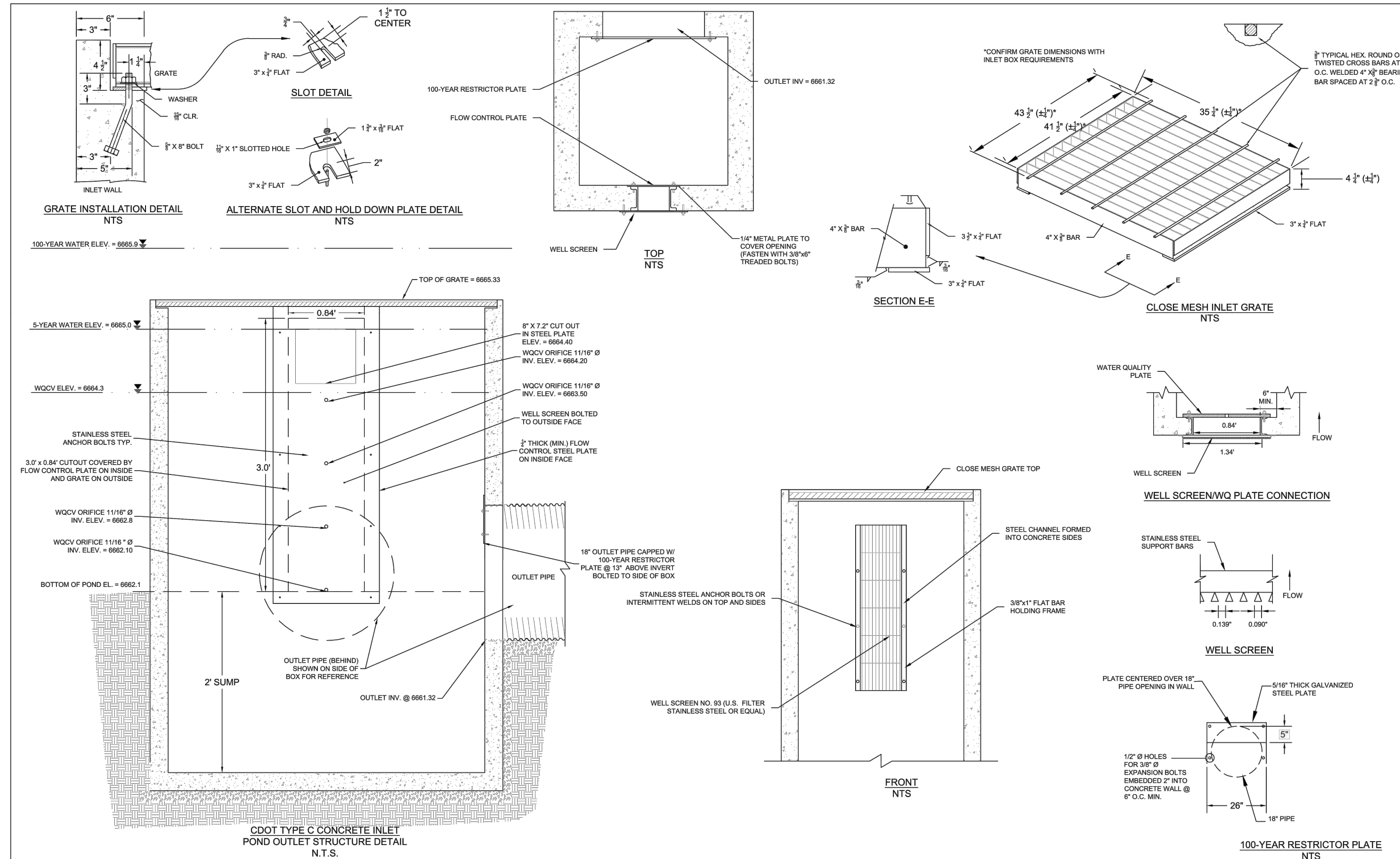

PROJECT: 2387-004	NO. 1	DATE: 12-23-21	BY: DS	DESCRIPTION: DRT Comments
DRAWN BY: DCS				
CHECKED BY: LCI				

These drawings are instruments of service provided by Landmark Consultants, Inc. and are not to be used for any type of construction or contracting unless signed and sealed by a Professional Engineer in the employ of Landmark Consultants, Inc.



CIVIL ENGINEERS | SURVEYORS
141 9th Street - P.O. Box 774943
Steamboat Springs, Colorado 80477
(970) 871-9494 www.LANDMARK-CO.com

Steamboat Basecamp
Ownership & Maintenance Plan
Outlet Structure Details

SHEET
2
Of 3 Sheets

OWNERSHIP AND MAINTENANCE (O&M) PLAN FOR STEAMBOAT BASECAMP EXTENDED DETENTION BASIN

- 1. GENERAL PROJECT INFORMATION**
- STEAMBOAT BASECAMP. LOT 1, WORLDWEST SUBDIVISION
 - RECEIVING WATER: ROADSIDE DITCH ON CURVE COURT. ULTIMATE OUTFALL YAMPA RIVER.
 - PROPERTY OWNER: MAY RIEGLER PROPERTIES
2201 WISCONSIN AVE NW
SUITE 200
WASHINGTON DC 20007
gary@mayrieglerr.com
 - AGENCY RESPONSIBLE FOR MAINTENANCE: SAME AS OWNER
 - DESIGN ENGINEER: LANDMARK CONSULTANTS, INC.
141 9TH STREET
STEAMBOAT SPRINGS, CO 80487
970-871-9494
ATTN: ERIC GRIEPPENTROG, P.E.
ERIK@LANDMARK-CO.COM

2. GENERAL FACILITY DESCRIPTION

THIS FACILITY IS AN EXTENDED DETENTION BASIN THAT WILL RELEASE THE WATER QUALITY CAPTURE VOLUME OVER 48 HOURS. THE FACILITY HAS BEEN ADOPTED AND APPROVED BY THE MAY RIEGLER PROPERTIES AS A PART OF THE STEAMBOAT BASECAMP PROJECT. IT WILL RECEIVE RUNOFF FROM 3.17-ACRES AND WILL OCCUPY A PARCEL OF 0.12-ACRES THAT WILL BE USED TO TREAT RUNOFF VIA SETTLING AND PROVIDE ACCESS FOR MAINTENANCE ACTIVITIES.

3. INSPECTION & MAINTENANCE FREQUENCY & PROCEDURE

A. MAINTENANCE ACTIVITIES SHALL OCCUR ACCORDING TO TABLE 3:

ACTIVITY	REQUIRED FREQUENCY
LAWN MOWING AND LAWN CARE	ROUTINE - DEPENDING ON AESTHETIC REQUIREMENTS
DEBRIS AND LITTER REMOVAL	ROUTINE - TWICE ANNUALLY UPON INSPECTION AND AS NEEDED FOLLOWING SIGNIFICANT RAINFALL EVENTS
SEDIMENT REMOVAL FROM FOREBAY AND MICROPOOL	ROUTINE - ONCE ANNUALLY AFTER COMPLETION OF SNOWMELT FROM CONTRIBUTING BASIN
NUISANCE CONTROL	NON-ROUTINE - HANDLE AS NECESSARY PER INSPECTION OR LOCAL COMPLAINTS
EROSION AND SEDIMENT CONTROL	NON-ROUTINE - PERIODIC REPAIR AS NECESSARY BASIN ON INSPECTION
STRUCTURAL	NON-ROUTINE REPAIR AS NEEDED BASED ON INSPECTIONS
INSPECTIONS	ROUTINE - TWO TIMES ANNUALLY, ONCE AFTER COMPLETION OF SNOWMELT AND ONCE AFTER SIGNIFICANT RAINFALL EVENT
SEDIMENT REMOVAL	NON ROUTINE - PERFORMED WHEN SEDIMENT ACCUMULATION OCCUPIES 20% OF WQCV (1.091-CF OR 1.4-FT DEEP). THIS MAY VARY CONSIDERABLY, BUT EXPECT TO DO THIS EVERY 15 TO 20 YEARS.

- B. REVISIONS TO MAINTENANCE FREQUENCY:**
- DATES/REASONS FOR CHANGES:
- TRAFFIC CONTROL: N/A
 - THE FACILITY DOES NOT REQUIRE CONFINED SPACE ENTRY PROCEDURES.
 - DEWATERING AND WATER CONTROL: DEWATERING OF THE MICRO-POOL BY PUMPING ONTO THE EDS'S BOTTOM GRASSES WILL BE NEEDED TO REMOVE ACCUMULATED SEDIMENT FROM THE MICRO-POOL'S BOTTOM.
 - DEBRIS, & TRASH REMOVAL & DISPOSAL
REMOVAL SHALL BE CONDUCTED IF THERE IS PRESENCE OF TRASH OR DEBRIS AT INSPECTION. SEDIMENT AND DEBRIS SHALL BE REMOVED MANUALLY USING A SHOVEL OR RAKE AND DISPOSED OF AT A LICENSED FACILITY. THE LONGEST DISTANCE BETWEEN THE EDGE OF AN ACCESS ROAD AND THE FAR CORNER OF A STRUCTURE REQUIRING SEDIMENT REMOVAL IS 35 FEET.
 - VEGETATION MANAGEMENT
SEE SECTION 3 OF THE NOTES ON THIS SHEET
 - WETLAND AREAS: N/A
 - DESCRIBE ADDITIONAL REQUIRED MAINTENANCE PROCEDURES AND FREQUENCIES - N/A
 - MATERIALS TESTING OF SEDIMENT REMOVED FROM SITE IS NOT REQUIRED.
 - ALL MAINTENANCE MATERIALS AND TOOLS SHALL BE REMOVED FROM THE SITE FOLLOWING MAINTENANCE COMPLETION.
- 3. EQUIPMENT, STAFFING, AND VEGETATION MANAGEMENT**
- EQUIPMENT REQUIRED: SHOVEL, RAKE, BACKHOE, CAMERA, DATA LOG / INSPECTION REPORT
 - STAFFING: ONE PERSON WHO IS QUALIFIED TO RUN THE REQUIRED EQUIPMENT IS REQUIRED FOR MAINTENANCE
 - SEED: SEED MIXES ARE AS FOLLOWS:

- 4. SNOW AND ICE CONTROL**
- FACILITY IS LOCATED WITHIN A SNOW STORAGE AREA. FACILITY SHALL BE INSPECTED AFTER SNOWMELT AND DEBRIS AND LITTER REMOVED.
- 5. RIGHT-OF-WAY, ADJACENT OWNERSHIP, & ACCESS**
- RIGHT-OF-WAY DESCRIPTION: CURVE COURT, ROW VARIES. SHIELD DRIVE, ROW VARIES.
 - ADJACENT OWNERSHIP: N/A
 - ACCESS INFORMATION AND DETAILS: MAINTENANCE ACCESS TO THE FACILITY IS VIA THE DRIVEWAY OFF OF SHIELD DRIVE. PROCEED TO THE SOUTH SIDE OF THE MAIN PARKING AREA.
 - MAINTENANCE OPERATIONS WILL NOT IMPACT OR OBSTRUCT RIGHT-OF-WAY AND A RIGHT-OF-WAY PERMIT IS NOT REQUIRED.
- 7. HYDRAULIC DESIGN**
- FLOW RATES (CFS):
BASE FLOW: 0 CFS
WQ EVENT: NA
5-YEAR: 10.26 CFS
100-YEAR: 31.01 CFS
 - VOLUMES, DEPTHS, & WSELS:
- | ITEM | VOLUME | WSEL | DEPTH | INVERT |
|--------------------------|--------------|--------|--------|--------|
| EXTENDED DETENTION BASIN | 213,429.6 CF | 4.8' | 6662.1 | |
| WQCV | 1,907 CF | 6663.9 | 1.8' | |
| 5-YEAR | 1,918 CF | 6663.9 | 1.8' | |
| 100-YEAR | 2,675 CF | 6664.2 | 2.1' | |
- C. WQCV DRAIN TIME = 40 HOURS
- 8. SENSITIVE AREAS, WETLANDS, & PERMITS**
- THE SITE INCLUDES 0.24-ACRES OF WETLANDS LOCATED NORTH OF THE DEVELOPMENT. MAINTENANCE ACTIVITIES WILL NOT IMPACT THE WETLANDS.
- 8. MISCELLANEOUS INFORMATION**
- PROJECT SURVEY:
TOPOGRAPHIC AND EXISTING CONDITIONS PER LANDMARK GROUND SURVEY 10-30-2020. SOME OFF-SITE AND ADJACENT PROPERTY INFORMATION WAS DIGITIZED FROM AERIAL IMAGERY. LANDMARK IS NOT RESPONSIBLE FOR THE ACCURACY OR COMPLETENESS OF THE EXISTING CONDITIONS AND/OR PROPERTY INFORMATION INCLUDING EASEMENTS AND ENCUMBRANCES AND THE OWNER ASSUMES ALL RISK WITH COMPLYING WITH THE LEGAL REQUIREMENTS OF THIS PROJECT.
PROJECT BENCHMARKS IS RECOVERED NO. 5 REBAR W/ 1 1/2" ALUMINUM CAP STAMPED LANDMARK LS 29039, ELEV=6667.80 NAVD 88. THE COORDINATE SYSTEM IS COLORADO COORDINATE SYSTEM, NORTH ZONE, NAD83 (2011), NAVD88, COMBINED SCALE FACTOR: (N+14)5966.11

PROJECT: 2387-004	NO. 1	DATE: 12-23-2021	BY: DCS	DESCRIPTION: DRT Comments
DRAWN BY: DCS				
CHECKED BY: LCI				

These drawings are instruments of service provided by Landmark Consultants, Inc. and are not to be used for any type of construction or contracting unless signed and sealed by a Professional Engineer in the employ of Landmark Consultants, Inc.



CIVIL ENGINEERS | SURVEYORS
141 9th Street - P.O. Box 774943
Steamboat Springs, Colorado 80477
(970) 871-9494 www.LANDMARK-CO.com

Steamboat Basecamp
Ownership & Maintenance Plan
Notes and Instructions

SHEET
3
Of 3 Sheets

CIVIL ENGINEERS | SURVEYORS
141 9th Street - P.O. Box 774943
Steamboat Springs, Colorado 80477
(970) 871-9494
www.LANDMARK-CO.com

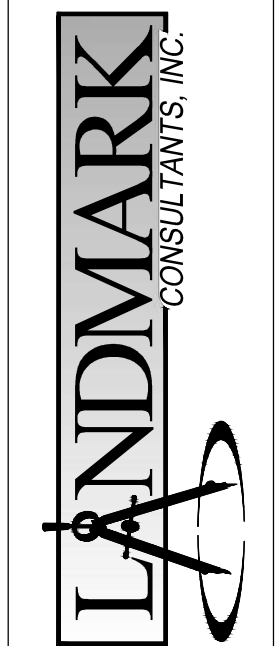

THESE DRAWINGS AND INSTRUMENTS OF SERVICE PROVIDED BY LANDMARK CONSULTANTS, INC. AND ARE NOT TO BE USED FOR ANY TYPE OF CONSTRUCTION OR CONTRACTING UNLESS SIGNED AND SEALED BY A PROFESSIONAL ENGINEER IN THE EMPLOY OF LANDMARK CONSULTANTS, INC.

PROJECT: 2387-004	DATE: 1-28-22	CONTACT: GHP	EMAIL: erik@landmark-co.com
NO.	DATE:	BY:	DESCRIPTION:

Steamboat Basecamp - Phase I
O&M PLAN
SHEET
C.520

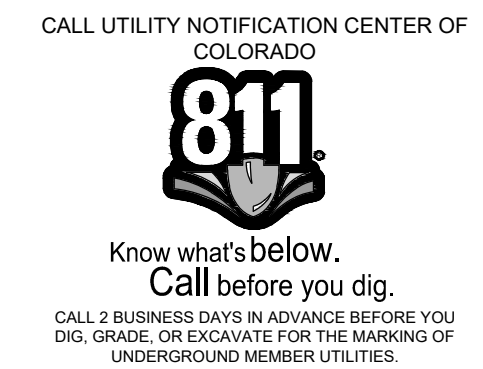

NOT VALID WITHOUT ORIGINAL SIGNATURE AND DATE

