



Ph: 970-871-6772 · Fax: 970-879-8023 · P.O. Box 775966 · Steamboat Springs, Colorado 80477

Final Drainage Report for Steamboat Airpark Preliminary Plat

Original Draft Drainage Letter: August 24, 2018

Revised Final Drainage Letter: July 23 2021

**Prepared by: Joe Wiedemeier, P.E.
Four Points Surveying & Engineering**

**P.O. Box 775966
Steamboat Springs, Colorado 80477
(970) 871-6772**

Appendices

- Appendix A: Drainage Exhibits – Existing & Proposed Conditions (D1 & D2)
- Appendix B: Drainage Basin Calculations
- Appendix C: Culvert Capacity Analysis & Hydraulic Calculations
- Appendix D: Gutter & Street Capacity Analysis & Hydraulic Calculations
- Appendix E: Ditch Capacity Analysis & Hydraulic Calculations
- Appendix F: French Drain Capacity Analysis



NOTE

City of Steamboat Springs plan review and approval is only for general conformance with City design criteria and City code. The City is not responsible for the accuracy and adequacy of the design, dimensions, and elevations that shall be confirmed and correlated at this job site. The City of Steamboat Springs assumes no responsibility for the completeness or accuracy of this document.

To: City of Steamboat Springs Engineering Department
137 10th Street
Steamboat Springs, CO

RE: Steamboat Airpark Preliminary Plat, FPSE 1670-001
Draft Drainage Letter

Dear Engineering Dept,

The following letter outlines the existing and proposed drainage conditions for the construction of a sidewalk, retaining wall, and associated drainage infrastructure for the Steamboat Airpark Preliminary Plat. The purpose of the sidewalk and retaining walls is to provide the public access to the Overlook Park Subdivision. Lot 1 consists of 133.9 acres and was platted March 20, 2008. FEMA map panels 08107C0694D and 08107C0713D were reviewed and the entire site is located in Zone X, an area of minimal flood hazard.

Existing Conditions

The existing conditions of Lot 1 West Acres Ranch Subdivision is made up of mountainous terrain and is mostly undeveloped. Soils consist of Phippsberg clay and Impass silty clay loam (Natural Resources Conservation Service [NRCS], 2014). Existing development includes a portion of Gloria Gossard Parkway and a newly developed access driveway to allow the owner access to the top of his property in order to plan for future development of an airpark. This driveway originates from Gloria Gossard Parkway and travels northerly following the existing topography and terminating near the highest point on the site. The final surface of the drive is subbase material.

Grading due to the driveway construction alters the existing basins to developed basins (DB). Two 30" culverts convey runoff from existing basin (EB) 4 under Gloria Gossard Parkway. The vegetation consists of sage brush, oak brush and native grasses. Gloria Gossard Parkway borders the southern portion of Lot 1 and is City right-of-way. A high point on the parkway is located near the center of the site, dividing EB's 1, 2, and 3 that flow westerly and EB's 3 and 4 that flow easterly. Westerly flows are already accounted for in the Overlook Park Drainage Final Report which will be amended accordingly due to the sidewalk addition. Easterly flows are analyzed solely in this drainage letter. Water in basin EB1 sheet flows south and off of the site by way of a 18" CMP culvert at design point one (DP1). Basin EB2 surface flows southwest to a roadside ditch and travels west to an existing sediment/water quality pond at DP2. This pond drains from seepage into the existing soils and offsite along existing drainage patterns. Basin EB3 sheet flows west offsite on existing drainage patterns with all basins ending up at the Yampa River.

This letter provides analysis of the drainage basins that are impacted by the sidewalk, retaining walls, and other associated drainage infrastructure including proposed culverts and ditches. There are no known drainage reports for adjacent developments.

Proposed Conditions

The proposed basins will maintain similar off-site drainage patterns except at Gloria Gossard Parkway where a proposed sidewalk and drainage infrastructure including culverts, gutters, ditches, and French drains will be installed. The new sidewalk will increase impervious surface area of the respective basins by 0.57 acres. Approximately 0.90 acres in total will be disturbed during construction. Drainage infrastructure additions include standard drainage curb and gutter installed along the north side of Gloria Gossard Parkway, two 12 foot wide drainage ditches, two corrugated HDPE culverts (18"), three stormwater inlets (Denver Type 16), and pervious

sidewalk shoulder and French drains as seen on the attached drainage drawings. Sub-basins (SB) shown in the attached exhibit depict area contributing to each culvert. Any 2:1 slopes created by the installation of the drive will be stabilized. Basin calculations for the easterly and westerly flowing basins are included in **Appendix A**.

Drainage Criteria and Methodology Used

This report was prepared in accordance with *Section 5.0 of the City of Steamboat Springs Engineering Standards, Drainage Criteria*. Effects of development on runoff were determined from the 5- and 100-year storms using the Rational Method for determining storm runoff. Table 1 summarizes the existing, and developed design and sub basin conditions.

Table 1: Comparison of existing and developed storm water runoff for the 5- and 100-year storms

Design points (DP's) as shown in the drainage plans were used to analyze drainage hydraulics at key points such as gutter/roadway capacity, drainage ditch capacity, inlet capacity, and culvert capacity. Table 2 summarizes design points and descriptions. Minor and major storm event flows were analyzed at the design points to ensure proper hydraulic capacity.

Table 2: Drainage Design Points

Design Point #	Description	Tributary Basin	Minor Storm Flow	Major Storm Flow
1	Denver Type 16 Inlet & 18" CMP culvert	DB1	5.72	31.64
2	Water quality pond	DB2	4.53	25.95
3	Denver Type 16 Inlet	SB14	0.41	0.83
4	Denver Type 16 Inlet	SB13	0.57	2.46
5	Roadway catch curb end	SB12	1.27	2.61
6	Roadway catch curb end	SB9	0.92	3.68
7	Drainage ditch end/Storm Sewer East inlet	DB5	1.47	5.50
8	Roadway catch curb end	SB11	0.69	3.05
9	Drainage ditch end/Storm Sewer West inlet	DB6	1.69	3.75

Culvert Sizing and Design Analysis

Two 18" storm system pipes (see plan for locations) will be installed in drainage pathways along Gloria Gossard Parkway to convey storm water east and west. Inlet control calculations were performed for the storm sewer east and west culverts under surcharged conditions using NRCS culvert analysis spreadsheet Version 5/2012. Culvert flows were also calculated using the manning's n equation to evaluate flow and velocity in absence of inlet control. All calculated velocities were in between 2 and 10 feet per second. In submerged conditions, the culverts would be under inlet control. Both culverts will effectively handle the minor and major storms without surcharging. Calculated peak flows and volumes at the culvert outlet points are not altered by a significant amount due to the sidewalk addition. Table 3 summarizes the culvert analysis. See culvert calculations in **Appendix B**.

Table 3: Culvert Sizing and Design Analysis

Design Point #	Culvert Capacity – Inlet Control (cfs)	Culvert Capacity – Manning’s n (cfs)	Minor Storm Peak Flow (cfs)	Major Storm Peak Flow (cfs)
7	7.1	12.32	1.47	5.50
9	8.3	12.04	1.69	3.75

Gutter Conveyance and Roadway Inundation Analysis

Curb and gutter installations along the northern side of Gloria Gossard Parkway will convey flow into the proposed drainage ditches. Gutter conveyance and associated gutter and roadway capacity were analyzed to ensure inundation requirements were met. Flows were calculated using UD_Inlet v4.05 spreadsheet for the street hydraulic capacity evaluation. Gloria Gossard road is 32 feet wide, which leaves 8 feet of street spread flow available. This leaves the required 12 feet of lane in each direction open. Design points 5, 6, and 8 as seen on the proposed conditions drainage exhibit were evaluated for curb/gutter and roadway capacity with 8 feet of spread flow into the street. All gutters and roadways will effectively convey both the minor and major storm events within the inundation limit and within the required velocity of 8 feet per second or less. Table 4 summarizes the curb/gutter and roadway conveyance analysis. See UD_Inlet v4.05 curb/gutter and roadway conveyance calculations in **Appendix C**.

Table 4: Gutter Conveyance Analysis with 8 Feet of Street Spread

Design Point #	Roadway/Gutter Capacity (cfs)	Minor Storm Flow (cfs)	Major Storm Flow (cfs)	Velocity (ft/sec)
5	3.10	1.27	2.61	7.80
6	3.90	0.92	3.68	7.35
8	3.10	0.69	3.05	7.80

Inlet Capacity Analysis

Two Type 16 inlets (see plan for locations) will be installed along Gloria Gossard Parkway at the midpoint of each proposed culvert to drain flow from the roadway. A type C inlet is proposed to be installed at the 18” culvert inlet at Design Point No. 1. Figure 1 Denver Type 16 capacity chart was used to approximate inlet capacity at approximately 5.16 inches of depth. Figure 2 is for a CDOT Type C inlet.

Figure 1: Denver Type 16 Inlet Capacity Chart

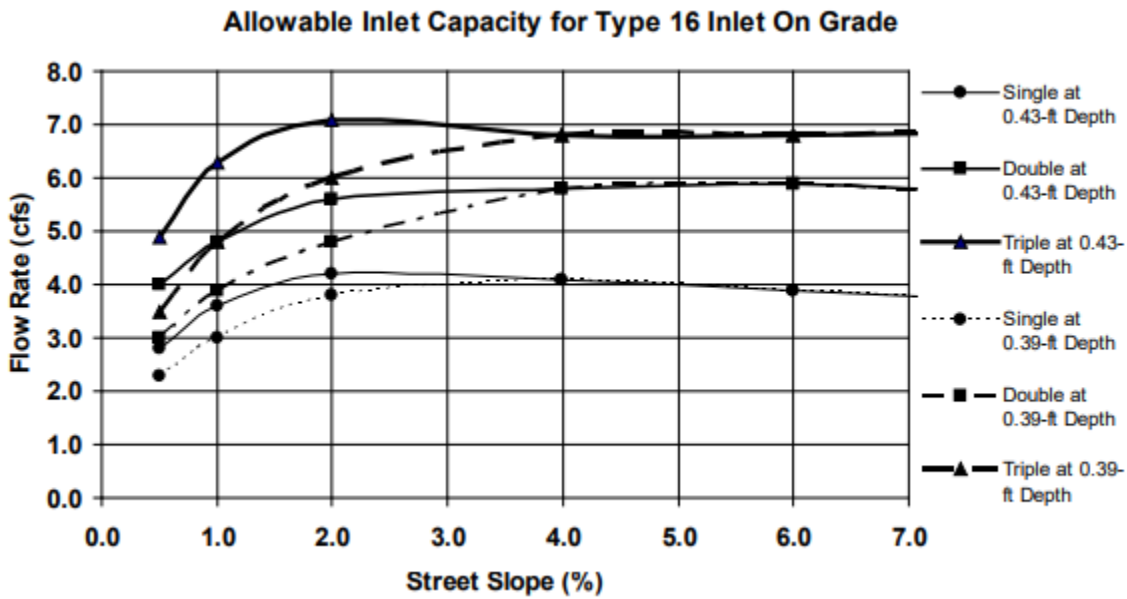

Source: City and County of Denver Storm Drainage Design and Technical Criteria, January 2006

Figure 2: Denver Type C Inlet Capacity Chart

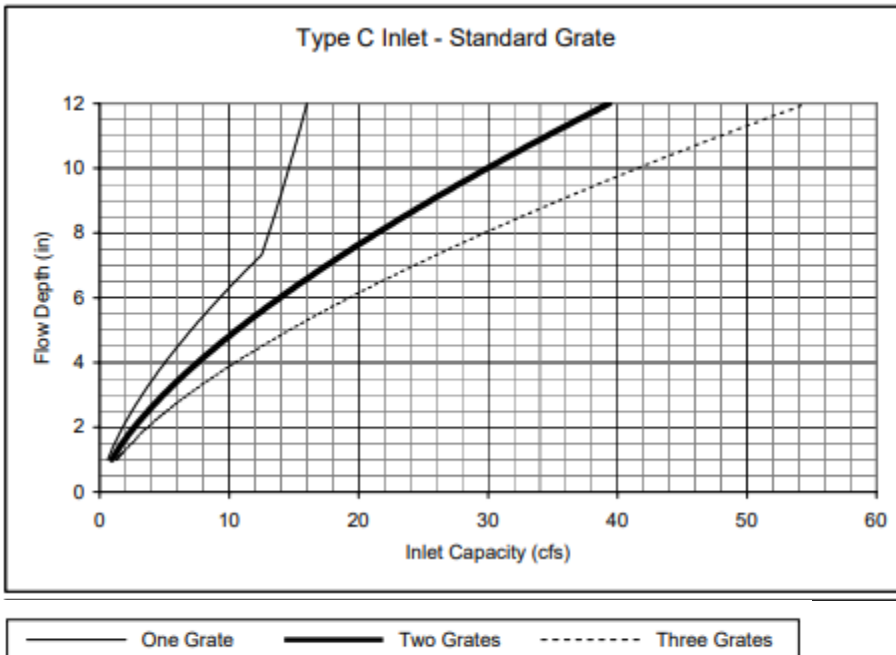

Source: City and County of Denver Storm Drainage Design and Technical Criteria, January 2006

The Type 16 inlets will effectively handle the minor and major storm events. The Type C inlet will handle the minor event without surcharging. Table 5 summarizes the inlet analysis.

Table 5: Inlet Capacity Analysis

Design Point #	No. of Inlets	Type of Inlet	Inlet Capacity (cfs)	Minor Storm Flow (cfs)	Major Storm Flow (cfs)
1	1	Type C	13.0	5.72	31.64
3	1	Type 16	4.0	0.41	0.83
4	1	Type 16	4.0	0.57	2.46

Drainage Ditch Capacity Analysis

Two drainage ditches (see plan for locations) will convey flow along Gloria Gossard Parkway and drain into the proposed culverts. The drainage ditches will effectively convey both the minor and major storm events. Table 6 summarizes the drainage ditch analysis. See drainage ditch calculations in **Appendix D**.

Table 6: Drainage Ditch Capacity Analysis

Design Point #	Drainage Ditch Capacity (cfs)	Minor Storm Flow (cfs)	Major Storm Flow (cfs)
7	45.57	1.47	5.50
9	78.92	1.69	3.75

Sidewalk Drainage

Portions of sidewalk are proposed to be installed along the steep slopes on the North side of Gloria Gossard. Stormwater runoff from the slopes must be managed to avoid conveyance over the surface of the sidewalk. Four Points recognizes this issue and also understands the vulnerability of slope failure along this area. As opposed to excavating into the hillside to construct a cutoff ditch, Four Points proposes installing a 6” PVC French along the northern shoulder of the sidewalk from approximately STA 5+87 to STA 17+80 and STA 22+20 to STA 27+05. The French drain is proposed to outfall within the proposed 12-foot roadside ditch, a proposed Denver Type 16 inlet, and the existing dual-culvert crossing extension basin. Cleanouts installed every 100-feet will facilitate maintenance. Geotextile fabric will inhibit vegetation intrusion. The primary concern in this instance is icing from snow melt along the hillside. Therefore it is not anticipated that capacity of the French drain system will need to be very great. 6” PVC capacity calcs were performed for the sidewalk slopes of 4.75% and 7%, the respective slopes for the aforementioned stations. See results in appendix. This does not include calculation of the additional flow capacity within the gravel medium of the French drain. The capacities calculated should facilitate the intended use. A large rainfall event may inundate the French drain and overflow into the street but this has been accounted for with the minor and major peak flow inundation determined for street flow.

Water Quality

Water quality for the westerly flows will be accounted for in the Final Overlook Park Drainage Report. Permanent water quality measures are not required for easterly flows as total development area is less than 1 acre.

Maintenance

Construction Phase

Temporary erosion and sediment control during construction is the responsibility of the general contractor. This responsibility includes acquisition of any required permits. All BMPs shall be constructed according to the City of Steamboat Spring standards. The contractor will install straw wattles as needed in sensitive drainage areas around the site. In addition, the contractor will be required to install a vehicle tracking entry at the proposed access location off of Gloria Gossard Parkway. The project site will be inspected a minimum of every 14 days and after each storm event until construction is complete and vegetation is in place. Inspection reports will be prepared for each of the inspections.

Post Construction Phase

After the construction, all of the drainage structures should be checked and maintained at least once per year. Ditch maintenance for the area will include mowing and removing litter/debris, managing nutrient and pesticide use, and repairing eroded or sparse grass areas on an annual basis by the property owner.

Conclusions

In conclusion, the development of a sidewalk, retaining walls and associated drainage infrastructure along Gloria Gossard Parkway as part of the Steamboat Airpark Preliminary Plat will not substantially impact existing drainage conditions. All proposed drainage infrastructure has been thoroughly evaluated and design of such is within the Steamboat Springs Drainage Criteria standards. Westerly flows will account for in the Final Approved Overlook Park Drainage Report. As the project continues to develop into a future airpark, any impacts to offsite drainage will be analyzed and any improvements will be implemented.

Certification Statement

I, hereby affirm that this drainage letter and plan for Steamboat Airpark Preliminary Plat was prepared by me or under my direct supervision for the owners thereof and is, the best of my knowledge, in accordance with the provisions of the City of Steamboat Springs Drainage Criteria and approved variances. I understand that the City of Steamboat Springs does not and will not assume liability for drainage facilities designed by others.

Joseph Linus Wiedemeier, PE 0054959
Four Points Surveying and Engineering

Appendix A

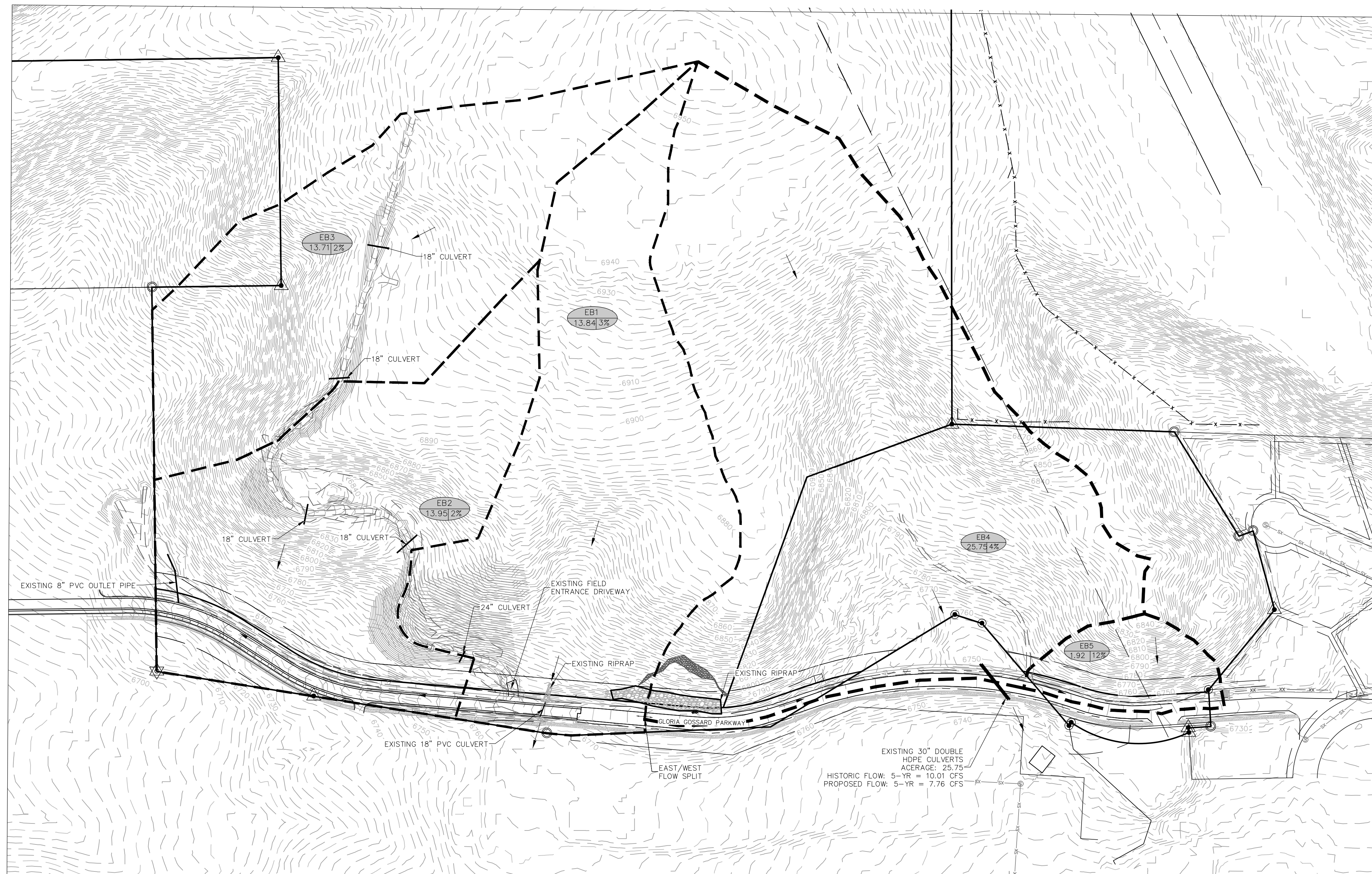

EXISTING DRAINAGE CONDITIONS



LEGEND	
	DRAINAGE DESIGN POINT
	DRAINAGE BASIN # SUB-BASIN #
	% IMPERVIOUS
	ACREAGE OF BASIN
	EXISTING DRAINAGE BASIN
	PROPOSED DRAINAGE BASIN
	PROPOSED DRAINAGE SUB BASIN

**LOT 1, WEST ACRES RANCH
SUBDIVISION
Steamboat Springs, CO 80487**

**DRAINAGE EXHIBIT
EXISTING CONDITIONS**

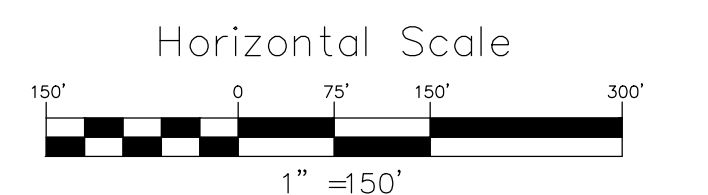

IF THIS DRAWING IS PRESENTED IN A FORMAT OTHER THAN 24" X 36", THE GRAPHIC SCALE SHOULD BE UTILIZED.

Contour Interval
2 Feet

NO.	DATE	REVISIONS	INT

DATE: 8-24-2018 DESIGN: JLW
 JOB NO. 1670-001 DRAFTED: JLW
 DWG. NAME REVIEW: MDM

**Four Points
Surveying and Engineering**

440 S. Lincoln Ave, Suite 4B
 P.O. Box 775966,
 Steamboat Springs, CO 80487
 (970)-871-6772
 wmppls@gmail.com



SHEET NO.
D1

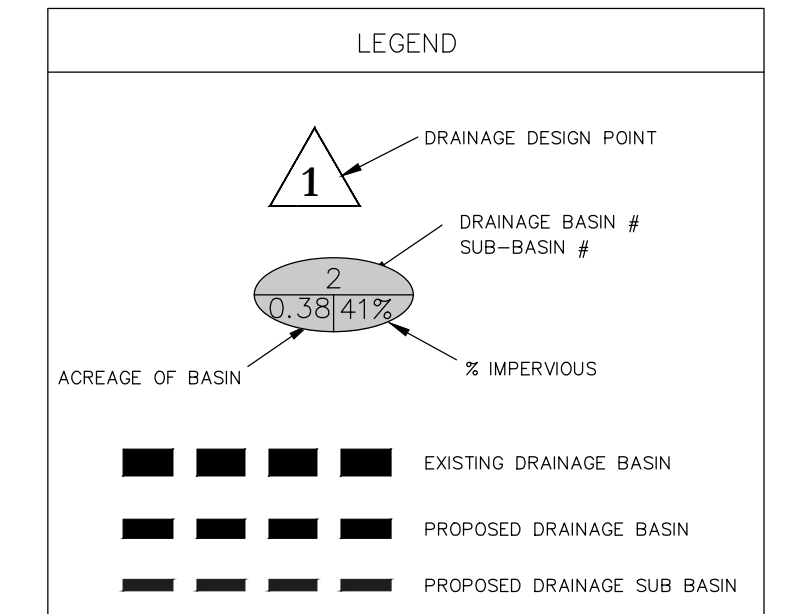
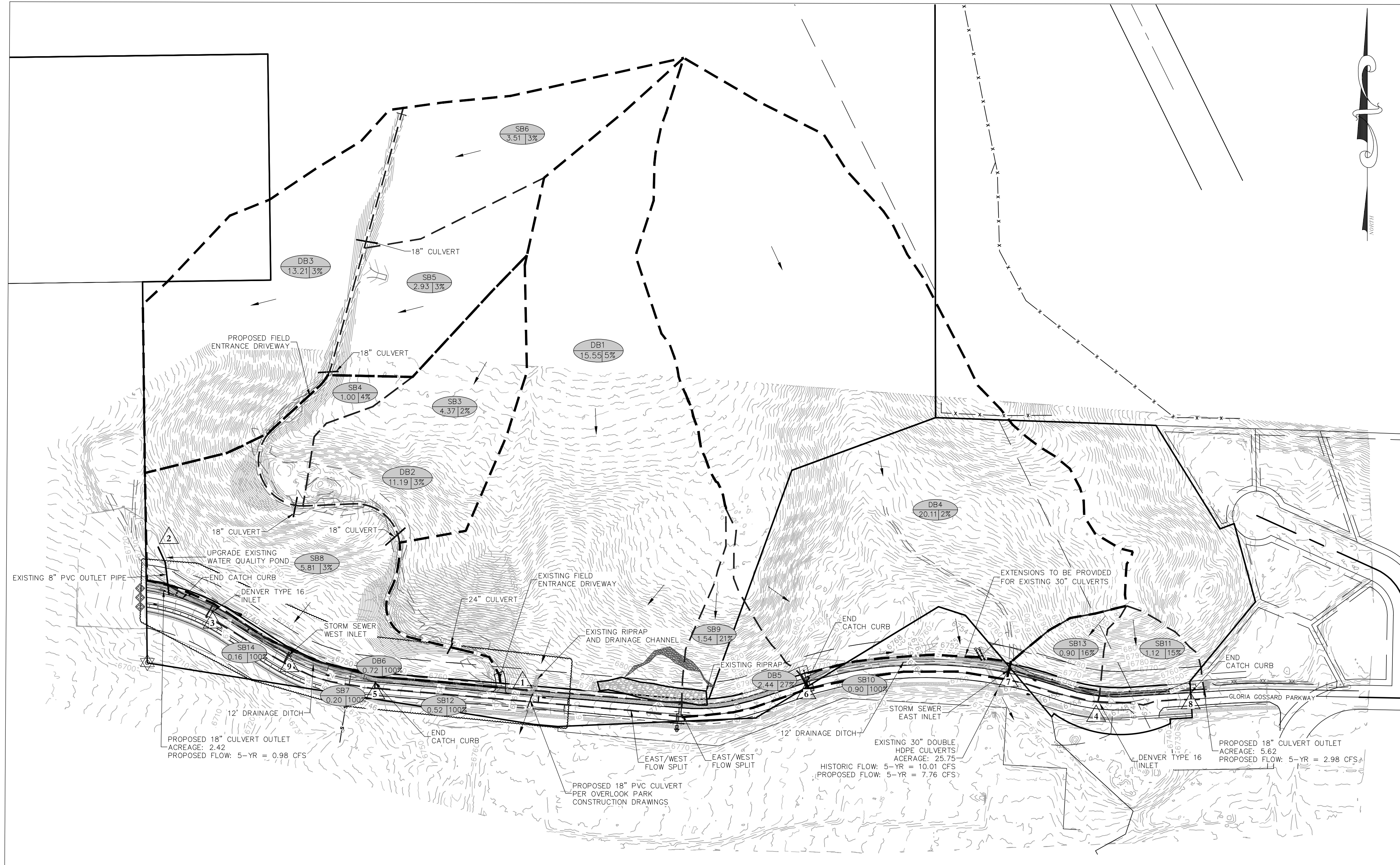

**STEAMBOAT AIRPARK
PRELIMINARY PLAT
Steamboat Springs, CO 80487**

**DRAINAGE EXHIBIT
PROPOSED CONDITIONS**

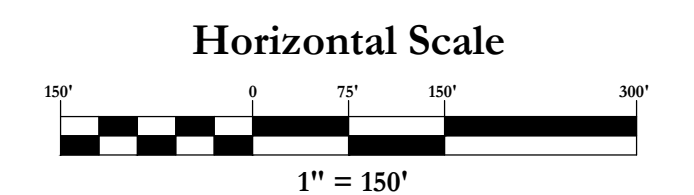

Contour Interval
2 Feet

NO.	DATE	REVISIONS	INT

DATE: 7-23-2021 DESIGN: JLW
 JOB NO. 1670-001 DRAFTED: JLW
 DWG. NAME REVIEW: MDM

**Four Points
Surveying and Engineering**

440 S. Lincoln Ave, Suite 4B
 P.O. Box 775966,
 Steamboat Springs, CO 80487
 (970)-871-6772
 wmmpepls@gmail.com



SHEET NO.
D2

PROPOSED DRAINAGE CONDITIONS

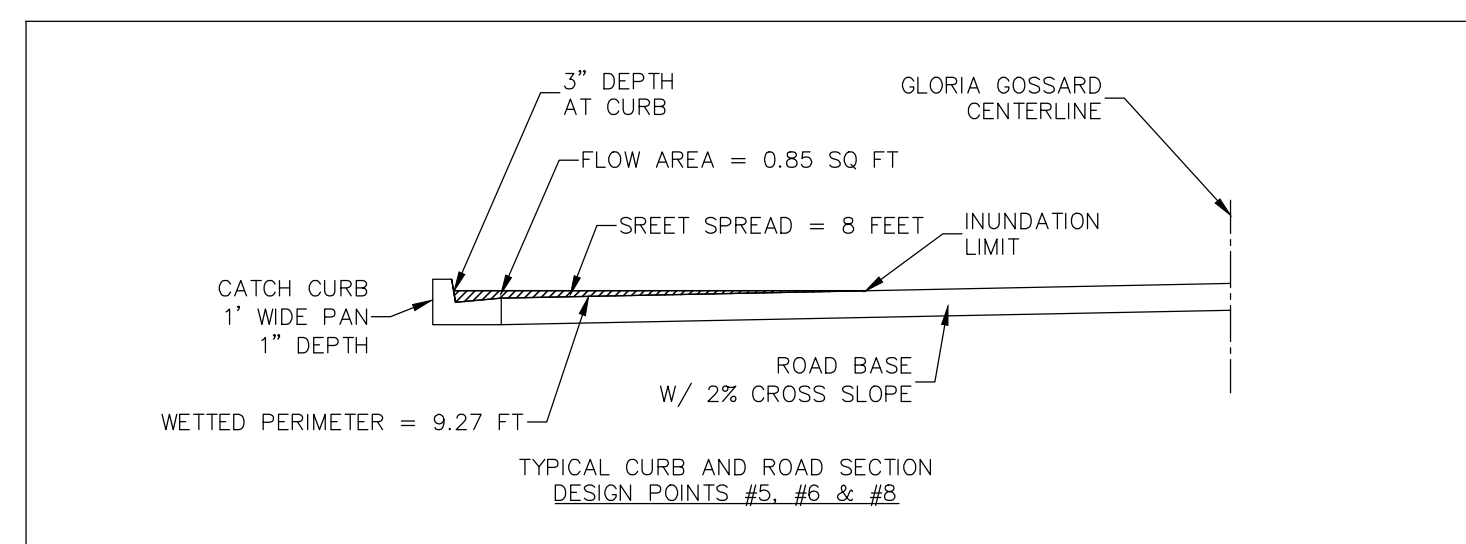

CURB AND GUTTER ROADWAY CONVEYANCE

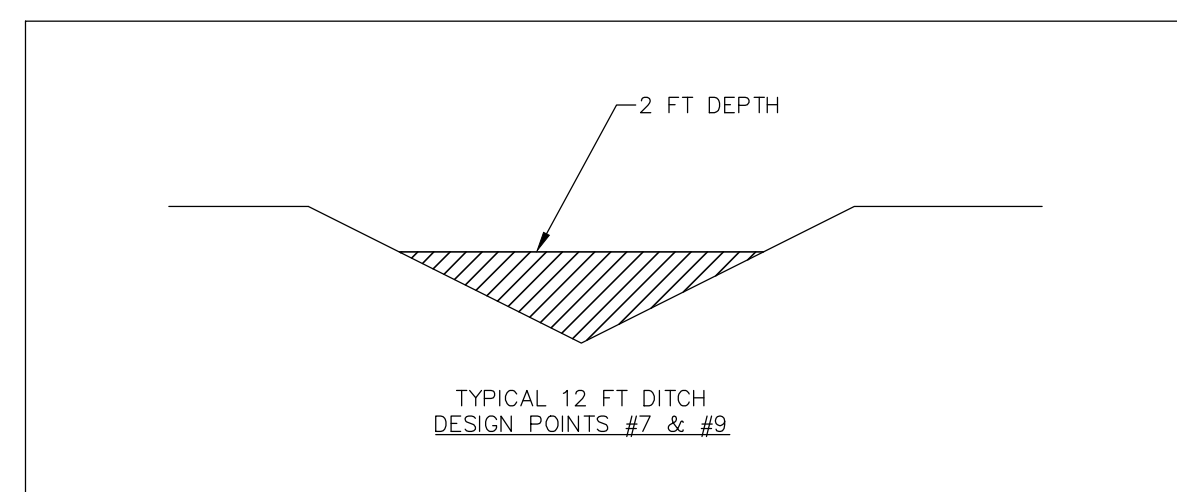

DITCH CONVEYANCE

Design Point #	Description
1	Type C Inlet
2	Water quality pond
3	Denver Type 16 Inlet
4	Denver Type 16 Inlet
5	Roadway catch curb end
6	Roadway catch curb end
7	Drainage ditch end/Storm Sewer East inlet
8	Roadway catch curb end
9	Drainage ditch end/Storm Sewer West inlet

Appendix B

RATIONAL METHOD RUNOFF ANALYSIS - EAST DRAINAGE

Job # 1670-001 Date: August 20, 2018
 Job Name Steamboat Airpark Revised:
 Designed by: JLW

Existing Basin 4 (EB4)

BASIN CHARACTERISTICS				TIME OF CONCENTRATION					RESULTS							
	Area, ac	% imp	Soil Type	Overland Flow - Surface Type 1		Overland Flow - Surface Type 2		Channel Flow		Tc, min	Event	C	i_t in/hr	A, acres	Q, cfs	
Landscape	25.35	2%	C	Surface Imperviousness	0.02	Surface Imperviousness	0.02	Land Surface	Paved Areas and Shallow Swales	Minimum	2-YR	0.07	1.6	25.75	2.68	
Asphalt Parking & Walkways	0.40	100%		Length, ft	300	Length, ft	0	Length, ft	0	Tc, min	5-YR	0.17	2.3	25.75	10.01	
Roof	0.00	90%	P2	Slope, percent	23.0000	Slope, percent	1.0000	Slope, ft/ft	1.0000	Final	10-YR	0.27	2.8	25.75	19.62	
Gravel	0.00	40%	1.4	Runoff Coefficient	0.162	Runoff Coefficient	0.162	Conveyance Coefficient	20	Tc, min	25-YR	0.39	3.3	25.75	32.61	
Other	0.00	0%		Velocity, ft/s		Velocity, ft/s		20.0		100-YR	0.51	4.3	25.75	56.97		
				Ti, min= 10.3		Ti, min= 0.0		Tt, min= 0.0								

Existing Basin 5 (EB5)

BASIN CHARACTERISTICS				TIME OF CONCENTRATION					RESULTS							
	Area, ac	% imp	Soil Type	Overland Flow - Surface Type 1		Overland Flow - Surface Type 2		Channel Flow		Tc, min	Event	C	i_t in/hr	A, acres	Q, cfs	
Landscape	1.72	2%	C	Surface Imperviousness	0.02	Surface Imperviousness	0.02	Land Surface	Paved Areas and Shallow Swales	Minimum	2-YR	0.12	1.6	1.92	0.39	
Asphalt Parking & Walkways	0.20	100%		Length, ft	300	Length, ft	0	Length, ft	0	Tc, min	5-YR	0.22	2.3	1.92	0.99	
Roof	0.00	90%	P2	Slope, percent	31.0000	Slope, percent	1.0000	Slope, ft/ft	1.0000	Final	10-YR	0.31	2.9	1.92	1.75	
Gravel	0.00	40%	1.4	Runoff Coefficient	0.162	Runoff Coefficient	0.162	Conveyance Coefficient	20	Tc, min	25-YR	0.42	3.4	1.92	2.74	
Other	0.00	0%		Velocity, ft/s		Velocity, ft/s		20.0		100-YR	0.54	4.5	1.92	4.61		
				Ti, min= 9.3		Ti, min= 0.0		Tt, min= 0.0								

Development Basin 4 (DB4)

BASIN CHARACTERISTICS				TIME OF CONCENTRATION					RESULTS							
	Area, ac	% imp	Soil Type	Overland Flow - Surface Type 1		Overland Flow - Surface Type 2		Channel Flow		Tc, min	Event	C	i_t in/hr	A, acres	Q, cfs	
Landscape	20.11	2%	C	Surface Imperviousness	0.02	Surface Imperviousness	0.02	Land Surface	Paved Areas and Shallow Swales	Minimum	2-YR	0.06	1.6	20.11	1.83	
Asphalt Parking & Walkways	0.00	100%		Length, ft	300	Length, ft	0	Length, ft	0	Tc, min	5-YR	0.16	2.4	20.11	7.76	
Roof	0.00	90%	P2	Slope, percent	35.0000	Slope, percent	1.0000	Slope, ft/ft	1.0000	Final	10-YR	0.26	3.0	20.11	15.61	
Gravel	0.00	40%	1.4	Runoff Coefficient	0.162	Runoff Coefficient	0.162	Conveyance Coefficient	20	Tc, min	25-YR	0.38	3.4	20.11	26.27	
Other	0.00	0%		Velocity, ft/s		Velocity, ft/s		20.0		100-YR	0.51	4.5	20.11	46.29		
				Ti, min= 8.9		Ti, min= 0.0		Tt, min= 0.0								

Development Basin 5 (DB5)

BASIN CHARACTERISTICS				TIME OF CONCENTRATION					RESULTS							
	Area, ac	% imp	Soil Type	Overland Flow - Surface Type 1		Overland Flow - Surface Type 2		Channel Flow		Tc, min	Event	C	i_t in/hr	A, acres	Q, cfs	
Landscape	5.01	2%	C	Surface Imperviousness	0.02	Surface Imperviousness	0.02	Land Surface	Paved Areas and Shallow Swales	Minimum	2-YR	0.13	1.6	5.62	1.18	
Asphalt Parking & Walkways	0.61	100%		Length, ft	300	Length, ft	0	Length, ft	0	Tc, min	5-YR	0.22	2.4	5.62	2.98	
Roof	0.00	90%	P2	Slope, percent	35.0000	Slope, percent	1.0000	Slope, ft/ft	1.0000	Final	10-YR	0.31	3.0	5.62	5.24	
Gravel	0.00	40%	1.4	Runoff Coefficient	0.162	Runoff Coefficient	0.162	Conveyance Coefficient	20	Tc, min	25-YR	0.42	3.4	5.62	8.16	
Other	0.00	0%		Velocity, ft/s		Velocity, ft/s		20.0		100-YR	0.54	4.5	5.62	13.71		
				Ti, min= 8.9		Ti, min= 0.0		Tt, min= 0.0								

Sub Basin 9 (SB9)

BASIN CHARACTERISTICS				TIME OF CONCENTRATION					RESULTS						
	Area, ac	% imp	Soil Type	Overland Flow - Surface Type 1		Overland Flow - Surface Type 2		Channel Flow		Tc, min	Event	C	i_t in/hr	A, acres	Q, cfs
Landscape	1.30	2%	C	Surface Imperviousness	0.02	Surface Imperviousness	0.02	Land Surface	Paved Areas and Shallow Swales	Minimum	2-YR	0.14	1.6	1.50	0.35

RATIONAL METHOD RUNOFF ANALYSIS - EAST DRAINAGE

Job # 1670-001 Date: August 20, 2018
 Job Name Steamboat Airpark Revised:
 Designed by: JLW

Asphalt Parking & Walkways	0.20	100%	P2 1.4	Length, ft	300	Length, ft	0	Length, ft	0	Tc, min	5-YR	0.24	2.3	1.50	0.83
Roof	0.00	90%		Slope, percent	31.0000	Slope, percent	1.0000	Slope, ft/ft	1.0000	5.0	10-YR	0.32	2.9	1.50	1.42
Gravel	0.00	40%		Runoff Coefficient	0.162	Runoff Coefficient	0.162	Conveyance Coefficient	20	Final	25-YR	0.43	3.4	1.50	2.19
Other	0.00	0%		Velocity, ft/s			20.0	Tc, min	9.3	100-YR	0.54	4.5	1.50	3.64	
1.50 15%				Ti, min=	9.3	Ti, min=	0.0	Tt, min=	0.0						

RATIONAL METHOD RUNOFF ANALYSIS - WEST DRAINAGE

Job # 1670-001 Date: September 25, 2017
 Job Name Steamboat Airpark Revised: August 20, 2018
 Designed by: MDM/JLW

Existing Basin 1 (EB1)

BASIN CHARACTERISTICS				TIME OF CONCENTRATION					RESULTS						
	Area, ac	% imp	Soil Type	Overland Flow - Surface Type 1		Overland Flow - Surface Type 2		Channel Flow		Tc, min	Event	C	<i>i_s</i> , in/hr	A, acres	Q, cfs
Landscape	13.53	2%	C	Surface Imperviousness	0.02	Surface Imperviousness	0.02	Land Surface	Paved Areas and Shallow Swales	Minimum	2-YR	0.07	1.6	13.84	1.46
Asphalt Parking & Walkways	0.12	100%		Length, ft	300	Length, ft	0	Length, ft	0	Tc, min	5-YR	0.17	2.3	13.84	5.53
Roof	0.00	90%	P2	Slope, percent	30.0000	Slope, percent	1.0000	Slope, ft/ft	1.0000	5.0	10-YR	0.27	2.9	13.84	10.86
Gravel	0.19	40%	1.4	Runoff Coefficient	0.162	Runoff Coefficient	0.162	Conveyance Coefficient	20	Final	25-YR	0.39	3.4	13.84	18.05
Other	0.00	0%		Velocity, ft/s		20.0		20.0	Tc, min						
				Ti, min=	9.4	Ti, min=	0.0	Tt, min=	0.0	9.4	100-YR	0.51	4.5	13.84	31.58

Existing Basin 2 (EB2)

BASIN CHARACTERISTICS				TIME OF CONCENTRATION					RESULTS						
	Area, ac	% imp	Soil Type	Overland Flow - Surface Type 1		Overland Flow - Surface Type 2		Channel Flow		Tc, min	Event	C	<i>i_s</i> , in/hr	A, acres	Q, cfs
Landscape	13.76	2%	C	Surface Imperviousness	0.02	Surface Imperviousness	0.02	Land Surface	Paved Areas and Shallow Swales	Minimum	2-YR	0.05	1.6	13.95	1.23
Asphalt Parking & Walkways	0.00	100%		Length, ft	300	Length, ft	0	Length, ft	0	Tc, min	5-YR	0.16	2.3	13.95	5.24
Roof	0.00	90%	P2	Slope, percent	28.0000	Slope, percent	50.0000	Slope, ft/ft	1.0000	5.0	10-YR	0.26	2.9	13.95	10.54
Gravel	0.19	0%	1.4	Runoff Coefficient	0.162	Runoff Coefficient	0.162	Conveyance Coefficient	20	Final	25-YR	0.38	3.4	13.95	17.75
Other	0.00	0%		Velocity, ft/s		20.0		20.0	Tc, min						
				Ti, min=	9.6	Ti, min=	0.0	Tt, min=	0.0	9.6	100-YR	0.51	4.4	13.95	31.28

Existing Basin 3 (EB3)

BASIN CHARACTERISTICS				TIME OF CONCENTRATION					RESULTS						
	Area, ac	% imp	Soil Type	Overland Flow - Surface Type 1		Overland Flow - Surface Type 2		Channel Flow		Tc, min	Event	C	<i>i_s</i> , in/hr	A, acres	Q, cfs
Landscape	13.71	2%	C	Surface Imperviousness	0.02	Surface Imperviousness	1	Land Surface	Grassed Waterways	Minimum	2-YR	0.06	1.6	13.71	1.22
Asphalt Parking & Walkways	0.00	100%		Length, ft	300	Length, ft	0	Length, ft	0	Tc, min	5-YR	0.16	2.3	13.71	5.20
Roof	0.00	90%	P2	Slope, percent	30.0000	Slope, percent	1.0000	Slope, ft/ft	1.0000	5.0	10-YR	0.26	2.9	13.71	10.45
Gravel	0.00	0%	1.4	Runoff Coefficient	0.162	Runoff Coefficient	0.9	Conveyance Coefficient	15	Final	25-YR	0.38	3.4	13.71	17.60
Other	0.00	0%		Velocity, ft/s		15.0		15.0	Tc, min						
				Ti, min=	9.4	Ti, min=	0.0	Tt, min=	0.0	9.4	100-YR	0.51	4.5	13.71	31.00

Development Basin 1 (DB1)

BASIN CHARACTERISTICS				TIME OF CONCENTRATION					RESULTS						
	Area, ac	% imp	Soil Type	Overland Flow - Surface Type 1		Overland Flow - Surface Type 2		Channel Flow		Tc, min	Event	C	<i>i_s</i> , in/hr	A, acres	Q, cfs
Landscape	15.00	2%	C	Surface Imperviousness	0.02	Surface Imperviousness	1	Land Surface	Grassed Waterways	Minimum	2-YR	0.07	1.4	15.55	1.63
Asphalt Parking & Walkways	0.30	100%		Length, ft	300	Length, ft	0	Length, ft	335	Tc, min	5-YR	0.18	2.1	15.55	5.72
Roof	0.00	90%	P2	Slope, percent	16.0000	Slope, percent	1.0000	Slope, ft/ft	0.0700	5.0	10-YR	0.28	2.6	15.55	11.04
Gravel	0.25	40%	1.4	Runoff Coefficient	0.162	Runoff Coefficient	0.9	Conveyance Coefficient	15	Final	25-YR	0.39	3.0	15.55	18.22
Other	0.00	0%		Velocity, ft/s		4.0		4.0	Tc, min						
				Ti, min=	11.6	Ti, min=	0.0	Tt, min=	1.4	13.0	100-YR	0.52	3.9	15.55	31.64

Development Basin 2 (DB2)

BASIN CHARACTERISTICS				TIME OF CONCENTRATION					RESULTS						
	Area, ac	% imp	Soil Type	Overland Flow - Surface Type 1		Overland Flow - Surface Type 2		Channel Flow		Tc, min	Event	C	<i>i_s</i> , in/hr	A, acres	Q, cfs
Landscape	11.89	2%	C	Surface Imperviousness	0.02	Surface Imperviousness	1	Land Surface	Grassed Waterways	Minimum	2-YR	0.10	1.5	12.90	1.85
Asphalt Parking & Walkways	0.60	100%		Length, ft	300	Length, ft	0	Length, ft	325	Tc, min	5-YR	0.20	2.1	12.90	5.49

RATIONAL METHOD RUNOFF ANALYSIS - WEST DRAINAGE

Job # 1670-001 Date: September 25, 2017
 Job Name Steamboat Airpark Revised: August 20, 2018
 Designed by: MDM/JLW

Roof	0.00	90%	P2	Slope, percent	27.0000	Slope, percent	1.0000	Slope, ft/ft	0.0370	5.0	10-YR	0.29	2.7	12.90	10.15
Gravel	0.41	40%	1.4	Runoff Coefficient	0.162	Runoff Coefficient	0.9	Conveyance Coefficient	15	Final	25-YR	0.40	3.1	12.90	16.32
Other	0.00	0%		Velocity, ft/s	2.9	Tc, min									
				Ti, min=	9.7	Ti, min=	0.0	Tt, min=	1.9	11.6	100-YR	0.53	4.1	12.90	27.95

Development Basin 3 (DB3)

BASIN CHARACTERISTICS				TIME OF CONCENTRATION					RESULTS						
	Area, ac	% imp	Soil Type	Overland Flow - Surface Type 1		Overland Flow - Surface Type 2		Channel Flow		Tc, min	Event	C	i, in/hr	A, acres	Q, cfs
Landscape	12.95	2%	C	Surface Imperviousness	0.02	Surface Imperviousness	1	Land Surface	Grassed Waterways	Minimum	2-YR	0.06	1.5	13.21	1.17
Asphalt Parking & Walkways	0.00	100%		Length, ft	300	Length, ft	0	Length, ft	325	Tc, min	5-YR	0.17	2.1	13.21	4.66
Roof	0.00	90%	P2	Slope, percent	19.0000	Slope, percent	1.0000	Slope, ft/ft	0.0700	5.0	10-YR	0.27	2.6	13.21	9.25
Gravel	0.26	40%	1.4	Runoff Coefficient	0.162	Runoff Coefficient	0.9	Conveyance Coefficient	15	Final	25-YR	0.38	3.1	13.21	15.49
Other	0.00	0%		Velocity, ft/s		Velocity, ft/s		4.0	Tc, min						
				Ti, min=	11.0	Ti, min=	0.0	Tt, min=	1.4	12.3	100-YR	0.51	4.0	13.21	27.16

Sub Basin 1 (SB1)

BASIN CHARACTERISTICS				TIME OF CONCENTRATION					RESULTS						
	Area, ac	% imp	Soil Type	Overland Flow - Surface Type 1		Overland Flow - Surface Type 2		Channel Flow		Tc, min	Event	C	i, in/hr	A, acres	Q, cfs
Landscape	1.85	2%	C	Surface Imperviousness	0.02	Surface Imperviousness	1	Land Surface	Grassed Waterways	Minimum	2-YR	0.14	1.5	2.14	0.47
Asphalt Parking & Walkways	0.28	100%		Length, ft	300	Length, ft	0	Length, ft	50	Tc, min	5-YR	0.24	2.2	2.14	1.12
Roof	0.00	90%	P2	Slope, percent	22.0000	Slope, percent	1.0000	Slope, ft/ft	0.0700	5.0	10-YR	0.32	2.8	2.14	1.93
Gravel	0.01	40%	1.4	Runoff Coefficient	0.162	Runoff Coefficient	0.9	Conveyance Coefficient	15	Final	25-YR	0.43	3.2	2.14	2.97
Other	0.00	0%		Velocity, ft/s		Velocity, ft/s		4.0	Tc, min						
				Ti, min=	10.4	Ti, min=	0.0	Tt, min=	0.2	10.6	100-YR	0.54	4.3	2.14	4.95

Sub Basin 2 (SB2)

BASIN CHARACTERISTICS				TIME OF CONCENTRATION					RESULTS						
	Area, ac	% imp	Soil Type	Overland Flow - Surface Type 1		Overland Flow - Surface Type 2		Channel Flow		Tc, min	Event	C	i, in/hr	A, acres	Q, cfs
Landscape	12.55	2%	C	Surface Imperviousness	0.02	Surface Imperviousness	1	Land Surface	Grassed Waterways	Minimum	2-YR	0.06	1.6	12.58	1.10
Asphalt Parking & Walkways	0.00	100%		Length, ft	300	Length, ft	0	Length, ft	240	Tc, min	5-YR	0.16	2.2	12.58	4.61
Roof	0.00	90%	P2	Slope, percent	30.0000	Slope, percent	1.0000	Slope, ft/ft	0.0700	5.0	10-YR	0.26	2.8	12.58	9.26
Gravel	0.03	40%	1.4	Runoff Coefficient	0.162	Runoff Coefficient	0.9	Conveyance Coefficient	15	Final	25-YR	0.38	3.3	12.58	15.59
Other	0.00	0%		Velocity, ft/s		Velocity, ft/s		4.0	Tc, min						
				Ti, min=	9.4	Ti, min=	0.0	Tt, min=	1.0	10.4	100-YR	0.51	4.3	12.58	27.44

Sub Basin 3 (SB3)

BASIN CHARACTERISTICS				TIME OF CONCENTRATION					RESULTS						
	Area, ac	% imp	Soil Type	Overland Flow - Surface Type 1		Overland Flow - Surface Type 2		Channel Flow		Tc, min	Event	C	i, in/hr	A, acres	Q, cfs
Landscape	4.33	2%	C	Surface Imperviousness	0.02	Surface Imperviousness	1	Land Surface	Grassed Waterways	Minimum	2-YR	0.06	1.5	4.37	0.37
Asphalt Parking & Walkways	0.00	100%		Length, ft	300	Length, ft	0	Length, ft	95	Tc, min	5-YR	0.17	2.1	4.37	1.51
Roof	0.00	90%	P2	Slope, percent	14.0000	Slope, percent	1.0000	Slope, ft/ft	0.0700	5.0	10-YR	0.26	2.6	4.37	3.02
Gravel	0.04	40%	1.4	Runoff Coefficient	0.162	Runoff Coefficient	0.9	Conveyance Coefficient	15	Final	25-YR	0.38	3.0	4.37	5.07
Other	0.00	0%		Velocity, ft/s		Velocity, ft/s		4.0	Tc, min						
				Ti, min=	12.1	Ti, min=	0.0	Tt, min=	0.4	12.5	100-YR	0.51	4.0	4.37	8.90

RATIONAL METHOD RUNOFF ANALYSIS - WEST DRAINAGE

Job # 1670-001 Date: September 25, 2017
 Job Name Steamboat Airpark Revised: August 20, 2018
 Designed by: MDM/JLW

Sub Basin 4 (SB4)

BASIN CHARACTERISTICS				TIME OF CONCENTRATION					RESULTS						
	Area, ac	% imp	Soil Type	Overland Flow - Surface Type 1		Overland Flow - Surface Type 2		Channel Flow		Tc, min	Event	C	<i>i_i</i> in/hr	A, acres	Q, cfs
Landscape	0.94	2%	C	Surface Imperviousness	0.02	Surface Imperviousness	1	Land Surface	Grassed Waterways	Minimum	2-YR	0.07	1.5	1.00	0.11
Asphalt Parking & Walkways	0.00	100%		Length, ft	300	Length, ft	0	Length, ft	80		Tc, min	5-YR	0.18	2.2	1.00
Roof	0.00	90%	P2	Slope, percent	23.0000	Slope, percent	1.0000	Slope, ft/ft	0.0700	5.0	10-YR	0.27	2.8	1.00	0.76
Gravel	0.06	40%	1.4	Runoff Coefficient	0.162	Runoff Coefficient	0.9	Conveyance Coefficient	15	Final	25-YR	0.39	3.2	1.00	1.26
Other	0.00	0%		Velocity, ft/s		4.0			Tc, min						
				Ti, min= 10.3		Ti, min= 0.0		Tt, min= 0.3		10.6	100-YR	0.52	4.3	1.00	2.20

Sub Basin 5 (SB5)

BASIN CHARACTERISTICS				TIME OF CONCENTRATION					RESULTS						
	Area, ac	% imp	Soil Type	Overland Flow - Surface Type 1		Overland Flow - Surface Type 2		Channel Flow		Tc, min	Event	C	<i>i_i</i> in/hr	A, acres	Q, cfs
Landscape	2.88	2%	C	Surface Imperviousness	0.02	Surface Imperviousness	1	Land Surface	Grassed Waterways	Minimum	2-YR	0.06	1.4	2.93	0.24
Asphalt Parking & Walkways	0.00	100%		Length, ft	300	Length, ft	0	Length, ft	0		Tc, min	5-YR	0.17	2.0	2.93
Roof	0.00	90%	P2	Slope, percent	9.0000	Slope, percent	1.0000	Slope, ft/ft	1.0000	5.0	10-YR	0.27	2.5	2.93	1.94
Gravel	0.05	40%	1.4	Runoff Coefficient	0.162	Runoff Coefficient	0.9	Conveyance Coefficient	15	Final	25-YR	0.38	2.9	2.93	3.26
Other	0.00	0%		Velocity, ft/s		15.0			Tc, min						
				Ti, min= 14.1		Ti, min= 0.0		Tt, min= 0.0		14.1	100-YR	0.51	3.8	2.93	5.71

Sub Basin 6 (SB6)

BASIN CHARACTERISTICS				TIME OF CONCENTRATION					RESULTS						
	Area, ac	% imp	Soil Type	Overland Flow - Surface Type 1		Overland Flow - Surface Type 2		Channel Flow		Tc, min	Event	C	<i>i_i</i> in/hr	A, acres	Q, cfs
Landscape	3.46	2%	C	Surface Imperviousness	0.02	Surface Imperviousness	1	Land Surface	Grassed Waterways	Minimum	2-YR	0.06	1.1	3.51	0.24
Asphalt Parking & Walkways	0.00	100%		Length, ft	300	Length, ft	0	Length, ft	0		Tc, min	5-YR	0.17	1.6	3.51
Roof	0.00	90%	P2	Slope, percent	2.5000	Slope, percent	1.0000	Slope, ft/ft	1.0000	5.0	10-YR	0.26	2.1	3.51	1.91
Gravel	0.05	40%	1.4	Runoff Coefficient	0.162	Runoff Coefficient	0.9	Conveyance Coefficient	15	Final	25-YR	0.38	2.4	3.51	3.22
Other	0.00	0%		Velocity, ft/s		15.0			Tc, min						
				Ti, min= 21.5		Ti, min= 0.0		Tt, min= 0.0		21.5	100-YR	0.51	3.2	3.51	5.63

Appendix C

Culvert Analysis Spreadsheet

Ver 5/2012

Client: 1670-001 West Acres
 Design By: JLW
 Comments: Sidewalk extension - Storm Sewer East

County: Routt
 Checked By: WNM

Date: 8/20/2018
 Date: 8/20/2018

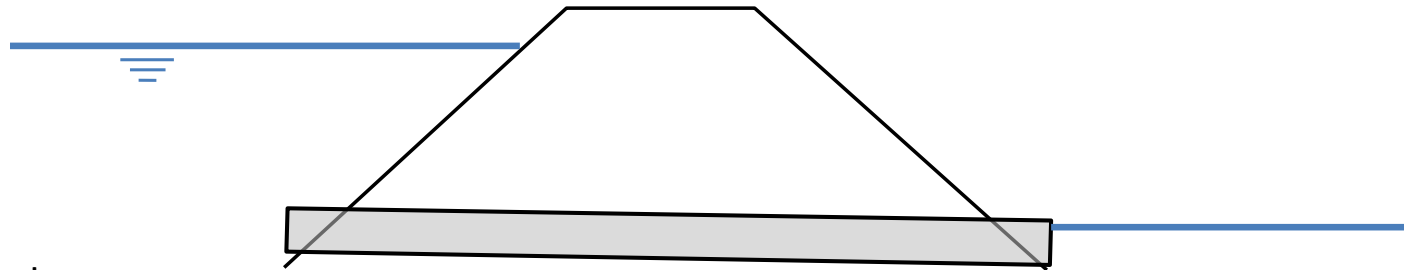

Inputs:

Headwater (Upstream Water Surface) Elevation:	6756.65	Feet
Culvert Inlet Invert Elevation:	6755.23	Feet
Culvert Diameter:	18.00	Inches
Length of Culvert:	231.00	Feet
Culvert Outlet Invert Elevation:	6743.70	Feet
Tailwater (Downstream) Elevation:	6743.00	Feet

Select Culvert Material: Corrugated_PE
 Select Culvert Inlet Type: Projecting - Thin Edge

Outputs:

CAPACITY = 5.3 cfs

INLET CONTROLS (Unsubmerged Equation)

Manning's n value: 0.024
 Entrance Coefficient, Ke: 0.9

Corrugated_PE
 Projecting - Thin Edge

Pipe Flow - Mannings Equation

Project: West Acres
Location: 18" Storm Sewer East
Created By: JLW
Date: 8/20/2017

$Q = (1.49/n) * A * R^{2/3} * S^{1/2}$
 $V = (1.49/n) * R^{2/3} * S^{1/2}$
 $Q = V * A$

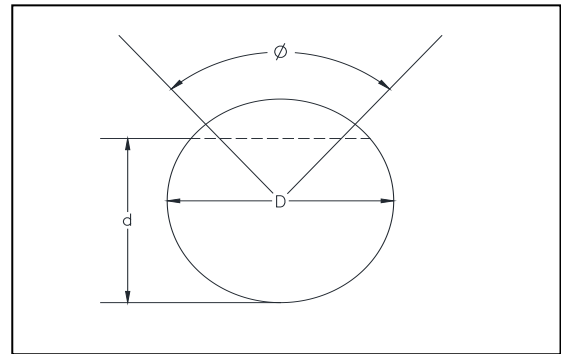

Input

D= 18 inches
d= 18 inches
n= 0.025 Manning's coefficient
S= 0.05 slope ft/ft
φ= 0.0 degrees
003B8

Area (A), sq. ft.	Wetted Perimeter, ft	Hydraulic Radius (R), ft
1.77	4.71	0.38

Velocity, ft/s= 6.91
Flow, cfs= 12.21

Pipe Flow - Mannings Equation

Project: West Acres
Location: 18" Storm Sewer East
Created By: JLW
Date: 8/20/2017

$$Q = (1.49/n) * A * R^{2/3} * S^{1/2}$$

$$V = (1.49/n) * R^{2/3} * S^{1/2}$$

$$Q = V * A$$

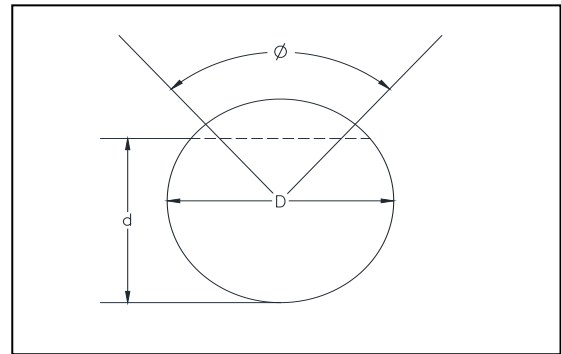

Input

D= 18 inches
 d= 17 inches
 n= 0.025 Manning's coefficient
 S= 0.044 slope ft/ft
 φ= 54.5 degrees

003B8

Area (A), sq. ft.	Wetted Perimeter, ft	Hydraulic Radius (R), ft
1.73	4.00	0.43

Velocity, ft/s= 7.13
 Flow, cfs= 12.32

Culvert Analysis Spreadsheet

Ver 5/2012

Client: 1670-001 West Acres
 Design By: JLW
 Comments: Sidewalk extension - Storm Sewer West

County: Routt
 Checked By: WNM

Date: 8/20/2018
 Date: 8/20/2018

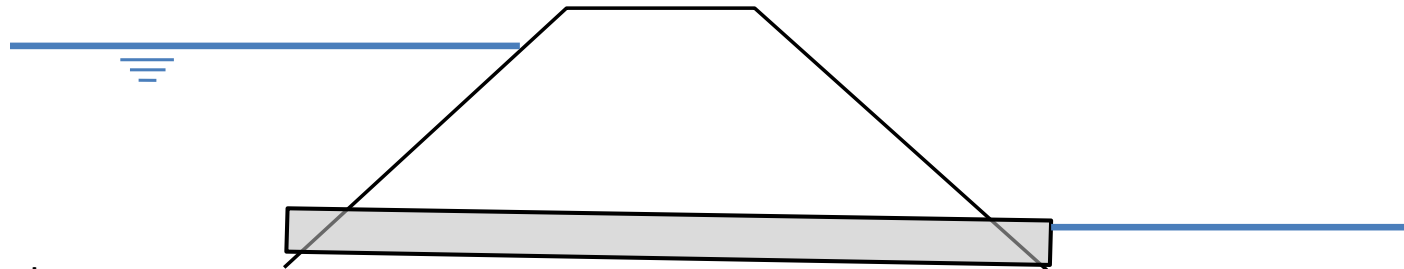

Inputs:

Headwater (Upstream Water Surface) Elevation:	6736.90	Feet
Culvert Inlet Invert Elevation:	6735.50	Feet
Culvert Diameter:	18.00	Inches
Length of Culvert:	260.00	Feet
Culvert Outlet Invert Elevation:	6720.50	Feet
Tailwater (Downstream) Elevation:	6721.00	Feet

Select Culvert Material: Corrugated_PE
 Select Culvert Inlet Type: Projecting - Thin Edge

Outputs:

CAPACITY = 5.3 cfs

Manning's n value: 0.024
 Entrance Coefficient, Ke: 0.9

INLET CONTROLS (Unsubmerged Equation)

Corrugated_PE
 Projecting - Thin Edge

Pipe Flow - Mannings Equation

Project: West Acres
Location: 24" Storm Sewer West
Created By: JLW
Date: 8/20/2017

$$Q = (1.49/n) * A * R^{2/3} * S^{1/2}$$

$$V = (1.49/n) * R^{2/3} * S^{1/2}$$

$$Q = V * A$$

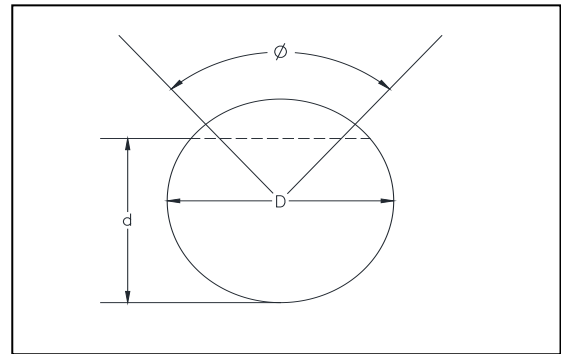

Input

D= 18 inches
 d= 17 inches
 n= 0.025 Manning's coefficient
 S= 0.042 slope ft/ft
 phi= 54.5 degrees

003B8

Area (A), sq. ft.	Wetted Perimeter, ft	Hydraulic Radius (R), ft
1.73	4.00	0.43

Velocity, ft/s= 6.96
 Flow, cfs= 12.04

Pipe Flow - Mannings Equation

Project: West Acres
Location: 24" Storm Sewer West
Created By: JLW
Date: 8/20/2017

$$Q = (1.49/n) * A * R^{2/3} * S^{1/2}$$

$$V = (1.49/n) * R^{2/3} * S^{1/2}$$

$$Q = V * A$$

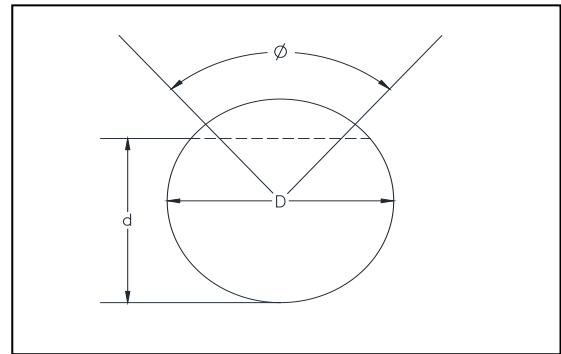

Input

D= 18 inches
 d= 17 inches
 n= 0.025 Manning's coefficient
 S= 0.043 slope ft/ft
 φ= 54.5 degrees

003B8

Area (A), sq. ft.	Wetted Perimeter, ft	Hydraulic Radius (R), ft
1.73	4.00	0.43

Velocity, ft/s= 7.05
 Flow, cfs= 12.18

Appendix D

ALLOWABLE CAPACITY FOR ONE-HALF OF STREET (Minor & Major Storm)

(Based on Regulated Criteria for Maximum Allowable Flow Depth and Spread)

Project:
Design Point

West Acres Ranch
DP 6

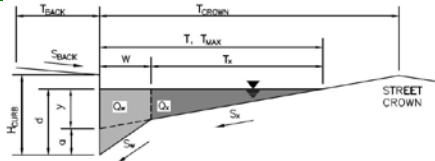

Gutter Geometry (Enter data in the blue cells)

Maximum Allowable Width for Spread Behind Curb
 Side Slope Behind Curb (leave blank for no conveyance credit behind curb)
 Manning's Roughness Behind Curb (typically between 0.012 and 0.020)
 Height of Curb at Gutter Flow Line
 Distance from Curb Face to Street Crown
 Gutter Width
 Street Transverse Slope
 Gutter Cross Slope (typically 2 inches over 24 inches or 0.083 ft/ft)
 Street Longitudinal Slope - Enter 0 for sump condition
 Manning's Roughness for Street Section (typically between 0.012 and 0.020)

$T_{BACK} =$ ft
 $S_{BACK} =$ ft/ft
 $n_{BACK} =$
 $H_{CURB} =$ inches
 $T_{CROWN} =$ ft
 $W =$ ft
 $S_x =$ ft/ft
 $S_w =$ ft/ft
 $S_0 =$ ft/ft
 $n_{STREET} =$

Max. Allowable Spread for Minor & Major Storm
 Max. Allowable Depth at Gutter Flowline for Minor & Major Storm
 Allow Flow Depth at Street Crown (leave blank for no)

	Minor Storm	Major Storm	
$T_{MAX} = $	<input type="text" value="8.0"/>	<input type="text" value="8.0"/>	ft
$d_{MAX} = $	<input type="text" value="6.0"/>	<input type="text" value="6.0"/>	inches
	<input type="checkbox"/>	<input type="checkbox"/>	check = yes

MINOR STORM Allowable Capacity is based on Spread Criterion
MAJOR STORM Allowable Capacity is based on Spread Criterion

	Minor Storm	Major Storm	
$Q_{allow} = $	<input type="text" value="3.9"/>	<input type="text" value="3.9"/>	cfs

Minor storm max. allowable capacity GOOD - greater than the design flow given on sheet 'Inlet Management'
Major storm max. allowable capacity GOOD - greater than the design flow given on sheet 'Inlet Management'

ALLOWABLE CAPACITY FOR ONE-HALF OF STREET (Minor & Major Storm)

(Based on Regulated Criteria for Maximum Allowable Flow Depth and Spread)

Project:

West Acres Ranch

Inlet ID:

DP 5

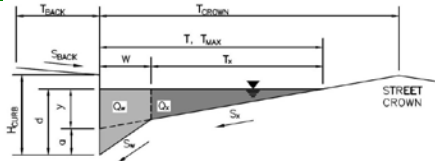

Gutter Geometry (Enter data in the blue cells)

Maximum Allowable Width for Spread Behind Curb
 Side Slope Behind Curb (leave blank for no conveyance credit behind curb)
 Manning's Roughness Behind Curb (typically between 0.012 and 0.020)
 Height of Curb at Gutter Flow Line
 Distance from Curb Face to Street Crown
 Gutter Width
 Street Transverse Slope
 Gutter Cross Slope (typically 2 inches over 24 inches or 0.083 ft/ft)
 Street Longitudinal Slope - Enter 0 for sump condition
 Manning's Roughness for Street Section (typically between 0.012 and 0.020)

$T_{BACK} =$ ft
 $S_{BACK} =$ ft/ft
 $n_{BACK} =$

$H_{CURB} =$ inches
 $T_{CROWN} =$ ft
 $W =$ ft
 $S_x =$ ft/ft
 $S_w =$ ft/ft
 $S_o =$ ft/ft
 $n_{STREET} =$

Max. Allowable Spread for Minor & Major Storm
 Max. Allowable Depth at Gutter Flowline for Minor & Major Storm
 Allow Flow Depth at Street Crown (leave blank for no)

	Minor Storm	Major Storm	
$T_{MAX} =$	<input type="text" value="8.0"/>	<input type="text" value="8.0"/>	ft
$d_{MAX} =$	<input type="text" value="6.0"/>	<input type="text" value="6.0"/>	inches
	<input type="checkbox"/>	<input type="checkbox"/>	check = yes

MINOR STORM Allowable Capacity is based on Spread Criterion
MAJOR STORM Allowable Capacity is based on Spread Criterion

	Minor Storm	Major Storm	
$Q_{allow} =$	<input type="text" value="3.1"/>	<input type="text" value="3.1"/>	cfs

Minor storm max. allowable capacity GOOD - greater than the design flow given on sheet 'Inlet Management'
Major storm max. allowable capacity GOOD - greater than the design flow given on sheet 'Inlet Management'

ALLOWABLE CAPACITY FOR ONE-HALF OF STREET (Minor & Major Storm)

(Based on Regulated Criteria for Maximum Allowable Flow Depth and Spread)

Project:

West Acres Ranch

Inlet ID:

DP 8

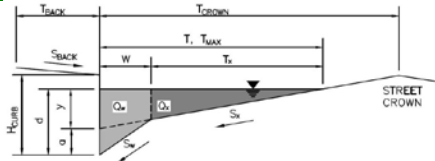

Gutter Geometry (Enter data in the blue cells)

Maximum Allowable Width for Spread Behind Curb
 Side Slope Behind Curb (leave blank for no conveyance credit behind curb)
 Manning's Roughness Behind Curb (typically between 0.012 and 0.020)
 Height of Curb at Gutter Flow Line
 Distance from Curb Face to Street Crown
 Gutter Width
 Street Transverse Slope
 Gutter Cross Slope (typically 2 inches over 24 inches or 0.083 ft/ft)
 Street Longitudinal Slope - Enter 0 for sump condition
 Manning's Roughness for Street Section (typically between 0.012 and 0.020)

$T_{BACK} =$ ft
 $S_{BACK} =$ ft/ft
 $n_{BACK} =$

$H_{CURB} =$ inches
 $T_{CROWN} =$ ft
 $W =$ ft
 $S_x =$ ft/ft
 $S_w =$ ft/ft
 $S_o =$ ft/ft
 $n_{STREET} =$

Max. Allowable Spread for Minor & Major Storm
 Max. Allowable Depth at Gutter Flowline for Minor & Major Storm
 Allow Flow Depth at Street Crown (leave blank for no)

	Minor Storm	Major Storm	
$T_{MAX} =$	<input type="text" value="8.0"/>	<input type="text" value="8.0"/>	ft
$d_{MAX} =$	<input type="text" value="6.0"/>	<input type="text" value="6.0"/>	inches
	<input type="checkbox"/>	<input type="checkbox"/>	check = yes

MINOR STORM Allowable Capacity is based on Spread Criterion
MAJOR STORM Allowable Capacity is based on Spread Criterion

	Minor Storm	Major Storm	
$Q_{allow} =$	<input type="text" value="3.1"/>	<input type="text" value="3.1"/>	cfs

Minor storm max. allowable capacity GOOD - greater than the design flow given on sheet 'Inlet Management'
Major storm max. allowable capacity GOOD - greater than the design flow given on sheet 'Inlet Management'

Appendix E

Open Channel Flow Calculation

Site: Gloria Gossard Design Point 7

Location: Gloria Gossard 12 ft Ditch

Capacity of Ditch @ 2 Foot Depth

Q	45.57	cfs	flow capacity
Q₅	2.98	cfs	Minor Storm Event Flow
Q₁₀₀	13.71	cfs	Major Storm Event Flow
n	0.03		Manning roughness
H	6		Side slopes of channel, H:V
V	3		
S	0.015	ft/ft	channel slope
b	0	ft	bottom width
A	12.00	sq ft	area of flow
P	24.33	ft	wetted perimeter
h	2.00	ft	flow depth
v	3.80	ft/s	flow velocity = Q/A
T	12.00	ft	top width
Fr	0.67		Froude Number, cannot be $0.80 < Fr < 1.2$

Source: Section 5.7, Steamboat Springs Drainage Criteria (2007)

Equation 5.7.1, Manning's Equation for normal flow in an open channel

Equation 5.7.2, Froude Number

Open Channel Flow Calculation

Site: Gloria Gossard Design Point 9

Location: Gloria Gossard 12 ft Ditch

Capacity of Ditch @ 2 Foot Depth

Q	78.92	cfs	flow capacity
Q ₅	6.70	cfs	Minor Storm Event Flow
Q ₁₀₀	35.82	cfs	Major Storm Event Flow
n	0.03		Manning roughness
H	6		Side slopes of channel, H:V
V	3		
S	0.045	ft/ft	channel slope
b	0	ft	bottom width
A	12.00	sq ft	area of flow
P	24.33	ft	wetted perimeter
h	2.00	ft	flow depth
v	6.58	ft/s	flow velocity = Q/A
T	12.00	ft	top width
Fr	1.16		Froude Number, cannot be $0.80 < Fr < 1.2$

Source: Section 5.7, Steamboat Springs Drainage Criteria (2007)

Equation 5.7.1, Manning's Equation for normal flow in an open channel

Equation 5.7.2, Froude Number

Appendix F

Channel Report

6-inch Perforated PVC Pipe Full Flow Capacity @ 7% Slope

Circular

Diameter (ft) = 0.50

Invert Elev (ft) = 100.00

Slope (%) = 7.00

N-Value = 0.013

Calculations

Compute by: Q vs Depth

No. Increments = 10

Highlighted

Depth (ft) = 0.50

Q (cfs) = 1.484

Area (sqft) = 0.20

Velocity (ft/s) = 7.56

Wetted Perim (ft) = 1.57

Crit Depth, Yc (ft) = 0.50

Top Width (ft) = 0.00

EGL (ft) = 1.39

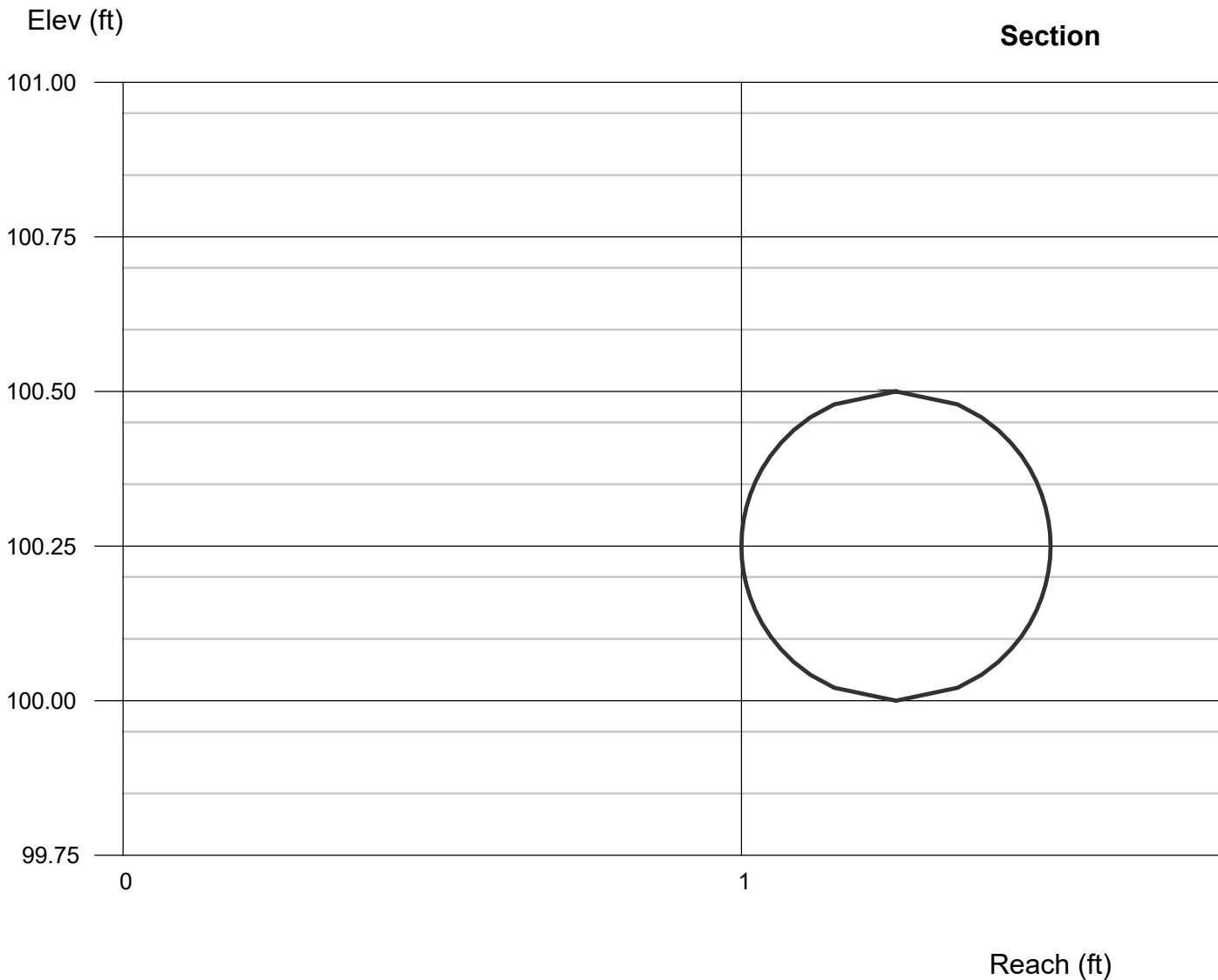

Channel Report

6-inch Perforated PVC Pipe Full Flow Capacity @ 4.75% Slope

Circular

Diameter (ft) = 0.50

Invert Elev (ft) = 100.00

Slope (%) = 4.75

N-Value = 0.013

Calculations

Compute by: Q vs Depth

No. Increments = 10

Highlighted

Depth (ft) = 0.50

Q (cfs) = 1.222

Area (sqft) = 0.20

Velocity (ft/s) = 6.22

Wetted Perim (ft) = 1.57

Crit Depth, Yc (ft) = 0.49

Top Width (ft) = 0.00

EGL (ft) = 1.10

