

C:\020261 2075 Walton Creek Rd Townhomes\Drawings\20261 TURN ANALYSIS.dwg, 12/5/2024 1:59:41 PM, Tim Maxwell

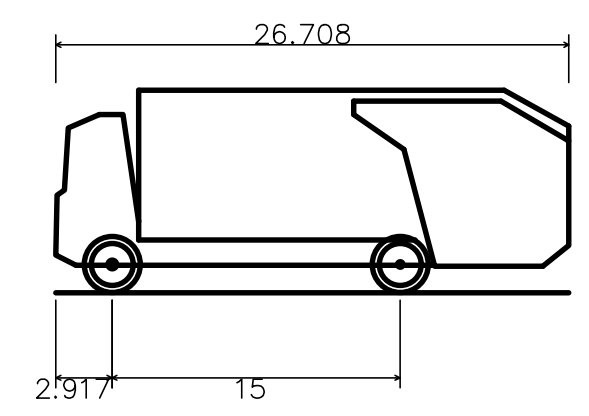
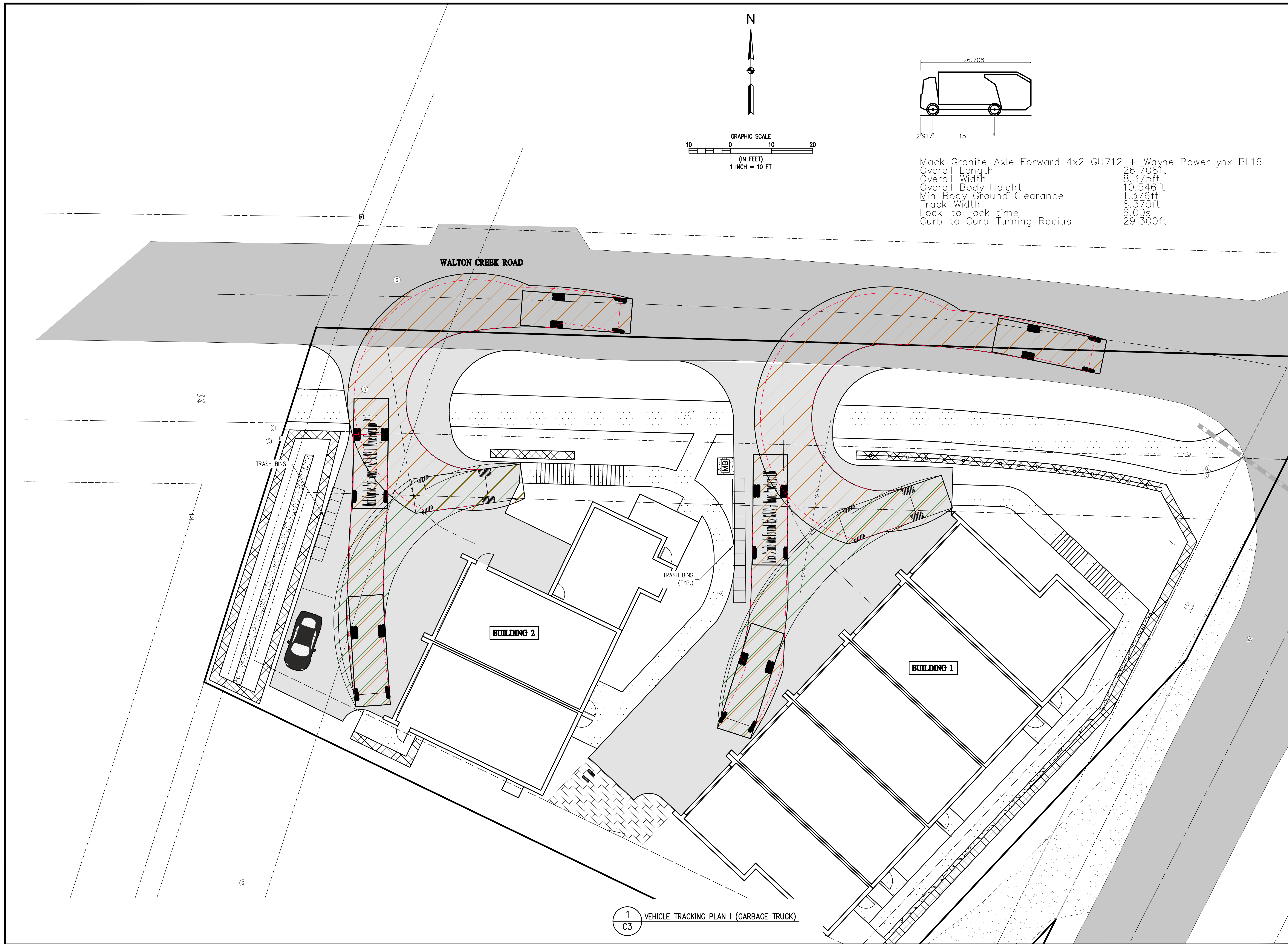

Mack Granite Axle Forward 4x2 GU712 + Wayne PowerLynx PL16
 Overall Length 26.708ft
 Overall Width 8.375ft
 Overall Body Height 10.546ft
 Min Body Ground Clearance 1.376ft
 Track Width 8.375ft
 Lock-to-lock time 6.00s
 Curb to Curb Turning Radius 29.300ft

1
C3 VEHICLE TRACKING PLAN I (GARBAGE TRUCK)

BASELINE
 Engineering · Planning · Surveying
 169 HILLTOP PKWY, SUITE 204 • STEAMBOAT SPRINGS, CO 80477
 P. 970.679.8225 • F. 303.940.9559 • www.baselinecorp.com

REVISION	DESCRIPTION	DATE	PREPARED BY	DESIGNED BY
1	ADDRESS DRT COMMENTS	8/22/2024	TJM	TJM
2	DEVELOPMENT PLAN RESUBMITTAL	12/4/2024	TJM	TJM

MAY RIEGLER PROPERTIES

CITY OF STEAMBOAT SPRINGS
 WALTON CREEK TOWNHOMES
 2075 WALTON CREEK ROAD
 VEHICLE TRACKING PLAN I (GARBAGE TRUCK)

ROUTT COUNTY

PREPARED UNDER THE DIRECT SUPERVISION OF

**PRELIMINARY
NOT FOR
CONSTRUCTION**

FOR AND ON BEHALF OF
 BASELINE CORPORATION

INITIAL SUBMITTAL 4/05/2024
 DRAWING SIZE 24" X 36"
 SURVEY FIRM LANDMARK, INC SURVEY DATE 5/29/2024
 JOB NO. C020261
 DRAWING NAME 20261 TURN ANALYSIS.dwg
 SHEET 3 OF 10