

No.	DATE	REVISIONS	
		DESCRIPTION	BY
1	2/12/2024	DRT REVIEW & RESPONSE	
2	4/18/2024	DRT REVIEW & RESPONSE	

**STEAMBOAT AIRPARK SUBDIVISION
CONSTRUCTION DRAWINGS
GLORIA GOSSARD PARKWAY
STEAMBOAT SPRINGS, CO 80487**

Horizontal Scale

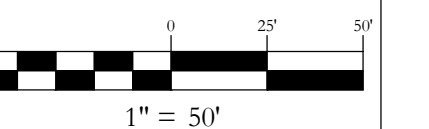

Contour Interval = 2 ft

DATE: 12-1-2023
JOB #: 1992-001
DRAWN BY: MDM
DESIGN BY: MDM
REVIEW BY: WNM

IF THIS DRAWING IS PRESENTED IN A FORMAT OTHER THAN A4 X 36", THE GRAPHIC SCALE SHOULD BE UTILIZED.

**CONSTRUCTION
SITE MANAGEMENT
PLAN 3**

DRAWING:

SHEET #

C20

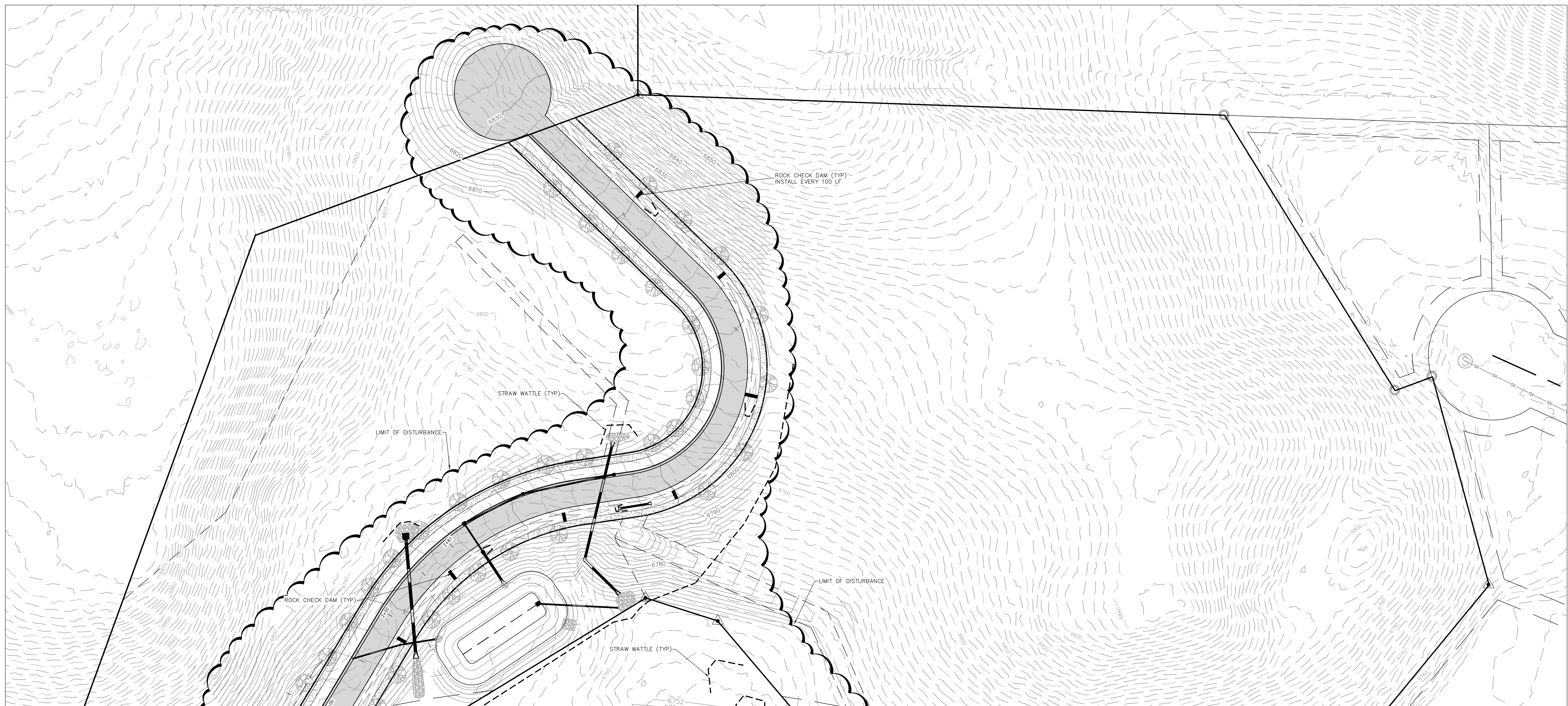

STANDARD NOTES FOR CONSTRUCTION SITE MANAGEMENT PLANS:

1. THIS PLAN SHALL BE KEPT ON SITE AT ALL TIMES AND UPDATED TO REFLECT ANY CHANGES.
2. CLEARING OR GRADING SHALL NOT BEGIN UNTIL ALL SEDIMENT CONTROL DEVICES HAVE BEEN INSTALLED.
3. CONTRACTOR IS RESPONSIBLE FOR INSTALLING AND MAINTAINING TEMPORARY EROSION AND SEDIMENT CONTROL DURING CONSTRUCTION AND ESTABLISHING ANY REQUIRED PERMANENT CONTROL MEASURES TO PREVENT RELEASE OF POLLUTANTS FROM THE PROJECT SITE.
4. CONTROL MEASURES SHALL BE USED, MODIFIED, AND MAINTAINED WHENEVER NECESSARY TO REFLECT CURRENT CONDITIONS. CONTROL MEASURES SHALL BE INSPECTED WEEKLY AND AFTER EVERY PRECIPITATION EVENT. ACCUMULATED SEDIMENT SHALL BE REMOVED FROM CONTROL MEASURES WHEN THE SEDIMENT LEVEL REACHES 1/2 HEIGHT OF THE CONTROL MEASURE.
5. THE CONTRACTOR SHALL PROMPTLY REMOVE ALL SEDIMENT, MUD, AND CONSTRUCTION DEBRIS THAT MAY ACCUMULATE IN THE RIGHT OF WAY, PRIVATE PROPERTY, OR WATER WAYS AS A RESULT OF THE CONSTRUCTION ACTIVITIES.
6. ALL INGRESS AND EGRESS POINTS ON TO THE DISTURBED SITE MUST BE STABILIZED WITH A VEHICLE TRACKING CONTROL PAD. ACCESS SHALL ONLY BE VIA APPROVED LOCATIONS AS SHOWN ON APPROVED CSMP.
7. TEMPORARY SOIL STABILIZATION MEASURES SHALL BE IMPLEMENTED WHERE GROUND DISTURBANCES HAVE TEMPORARILY OR PERMANENTLY CEASED FOR 14 DAYS OR FOR AREAS OF LAND DISTURBANCE WITHIN ONE GROWING SEASON.
8. CONCRETE WASTE AND WASHOUT WATER FROM MIXING TRUCKS SHALL BE CONTAINED ON SITE, REMOVED FROM THE SITE, AND PROPERLY DISPOSED. MATERIALS SHOULD NOT ENTER STATE WATERS.
9. CONTRACTOR IS RESPONSIBLE FOR COMPLYING WITH ALL LOCAL, STATE, AND FEDERAL LAWS. IN ADDITION CONTRACTOR MUST OBTAIN REQUIRED PERMITS.
10. EMERGENCY ACCESS MUST BE KEPT OBSTACLE FREE AND PASSABLE AT ALL TIMES.
11. FOR ANY WORK TO BE DONE IN THE RIGHT OF WAY, COORDINATE WITH THE CITY ROW MANAGER REGARDING SPECIAL PERMITTING. NO WORK SHALL BE CONDUCTED IN THE ROW BETWEEN NOVEMBER 1 AND MAY 1 WITHOUT PRIOR APPROVAL FROM THE DIRECTOR OF PUBLIC WORKS.
12. WHERE REQUIRED AS PART OF THE ROW PERMIT OR WHERE SITE WORK AFFECTS THE PEDESTRIAN OR VEHICLE TRAVEL WAY, TRAFFIC CONTROL SHALL BE INSTALLED. ALL TRAFFIC CONTROL SHALL BE IN ACCORDANCE WITH THE MANUAL ON UNIFORM TRAFFIC CONTROL DEVICES, LATEST EDITION.
13. SIDEWALKS ADJACENT TO CONSTRUCTION SITES SHALL BE MAINTAINED, FOR PUBLIC USE, BY THE CONTRACTOR. IN AREAS WHERE CONSTRUCTION IS TAKING PLACE NEXT TO THE SIDEWALK AND OVERHEAD HAZARDS ARE POSSIBLE, SITE IS RESPONSIBLE FOR INSTALLING AND MAINTAINING SIDEWALK PROTECTION.

PURPOSE
TO REDUCE THE AMOUNT OF MUD TRANSPORTED ONTO PUBLIC ROADS BY MOTOR VEHICLES OR RUNOFF.

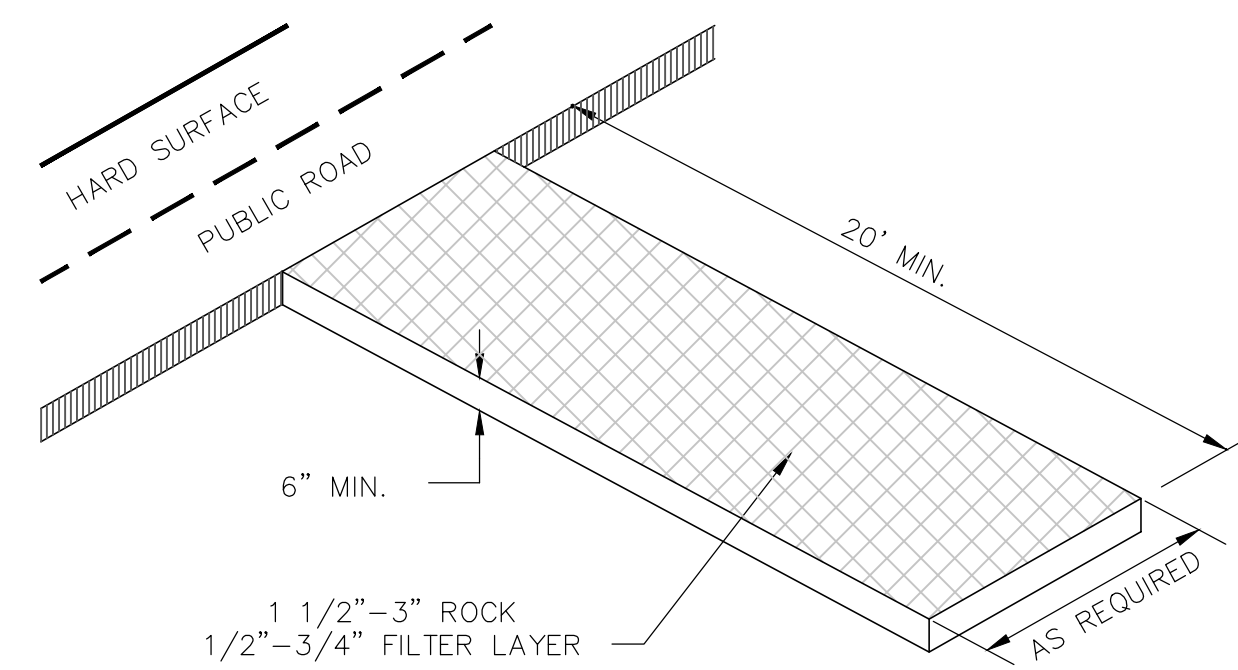

VEHICLE TRACKING CONTROL
N.T.S.

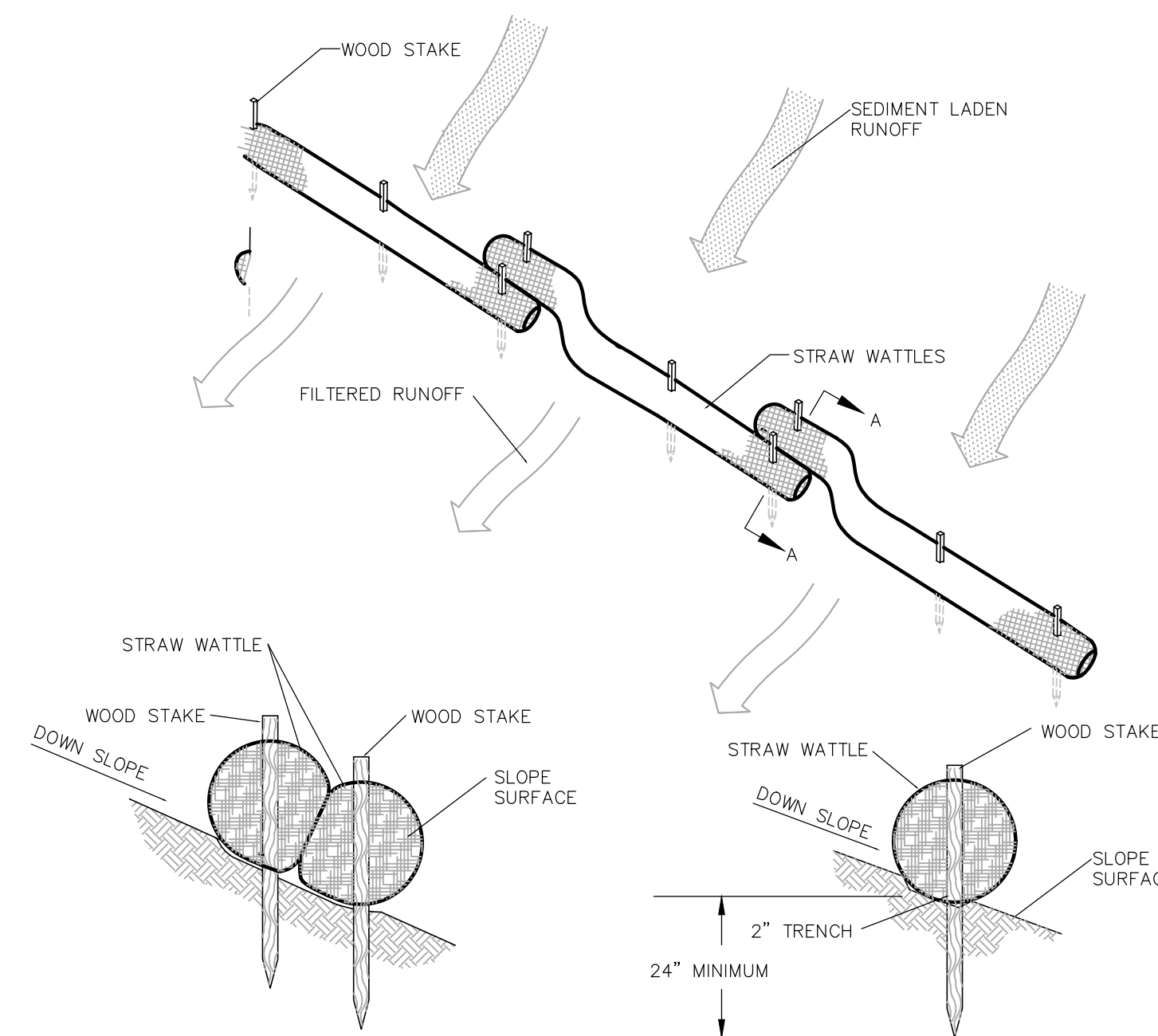

SECTION A-A

STRAW WATTLE
N.T.S.

MAINTAIN 6" SPOILOVER

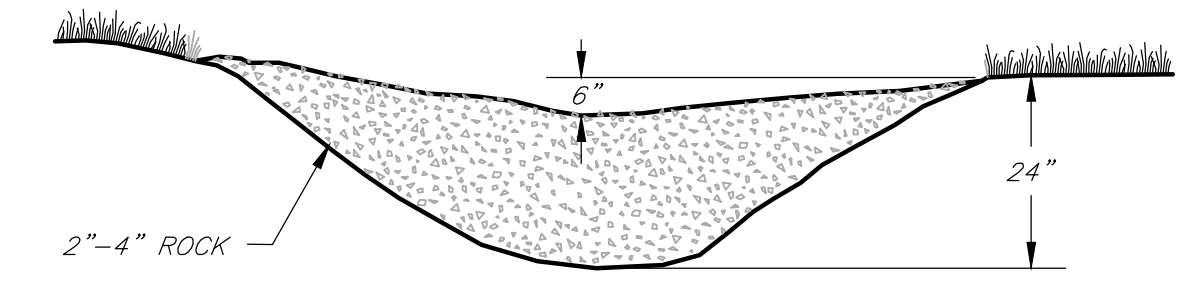

ROCK CHECK DAM
N.T.S.