

ANTLERS AT CHRISTIE BASE
RECEPTION NO. 558897

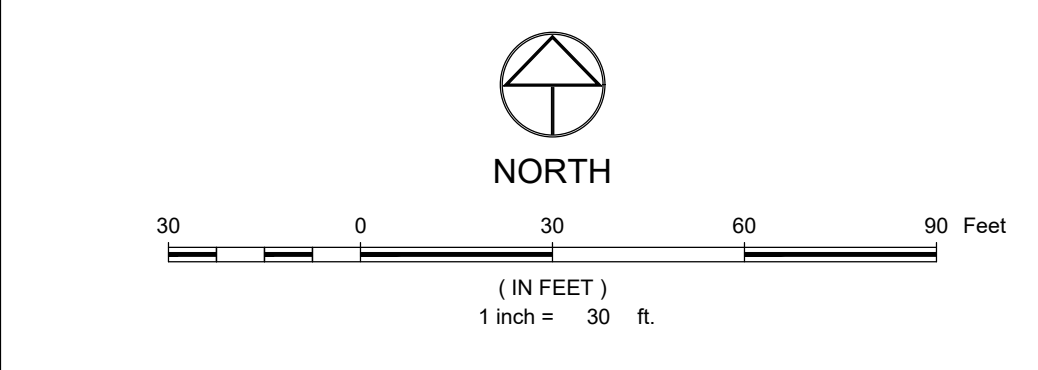

EXISTING CONDITIONS LEGEND:

PROPERTY BOUNDARY	---
ADJACENT PROPERTY BOUNDARY	---
EASEMENT	---
SECTION LINE	---
CENTERLINE	---
PROPERTY MONUMENT	○
SECTION CORNER	○
HIGHWATER MARK	---
FEMA FLOODWAY	---
EDGE OF WATER	---
WATER BODY SETBACK	---
BUILDING	---
ROOF LINE/OVERHANG	---
DECK	---
FENCE	---
MAJOR CONTOUR	---
MINOR CONTOUR	---
ASPHALT	---
CONCRETE	---
GRAVEL	---
SIGN	---
SANITARY SEWER LINE MARKER MANHOLE AND CLEANOUT	---
SEPTIC TANK LID AND VENT PIPE	---
WATER LINE MARKER, FIRE HYDRANT GATE VALVE, CURB STOP & METER	---
FIRE DEPT. CONNECTION, YARD HYDRANT, VENT PIPE, WATER MANHOLE AND WELL	---
GAS LINE MARKER, VALVE, MANHOLE, VAULT, METER AND SHUTOFF	---
PROPANE TANK (BURIED)	---
CABLE LINE MARKER, VAULT AND PEDESTAL	---
DUCT BANK	---
SATELLITE DISH	---
FIBER OPTIC LINE MARKER, VAULT & PEDESTAL	---
TELEPHONE LINE MARKER, VAULT, PEDESTAL AND MANHOLE	---
ELECTRIC LINE MARKER, TRANSFORMER, METER AND SECONDARY PEDESTAL	---
ELECTRIC MANHOLE, OUTLET, GENERATOR AND JUNCTION BOX	---
LIGHT POLE, STREET LIGHT, TRAFFIC SIGNAL, TRAFFIC CONTROL VAULT AND CABINET	---
OVERHEAD UTILITY LINE GUY POLE, UTILITY POLE & GUY WIRE	---
EDGE OF WATER	---
DITCH/SWALE	---
CULVERT W/ END SECTIONS	---
STORM MANHOLE, MANHOLE INLET, GRATE INLET AND CURB INLET	---
AIR CONDITIONER, MAILBOX, NEWSTAND, TRASH CAN, MISC. MANHOLE	---
BOLLARD, BOLLARD W/ LIGHT FLAG POLE AND DELINEATOR	---
STUMP, BOULDER AND IRRIGATION VALVE BOX	---
CONIFEROUS AND DECIDUOUS TREE (SCALED TO APPROXIMATE DRIPLINE)	---
CONIFEROUS AND DECIDUOUS SHRUB (SCALED TO APPROXIMATE DRIPLINE)	---

CALL UTILITY NOTIFICATION CENTER OF
COLORADO
811
Know what's below.
Call before you dig.
CALL 2 BUSINESS DAYS IN ADVANCE BEFORE YOU
DIG, GRADE, OR EXCAVATE FOR THE MARKING OF
UNDERGROUND MEMBER UTILITIES.

REVIEW SET
NOT FOR CONSTRUCTION

NO.	DATE	BY	DESCRIPTION

PROJECT:	2833-003
DATE:	3/15/2024
CONTACT:	Eric Gerspacher
EMAIL:	eng@landmark-co.com

DRAWING FILENAME: Y:\2023\2024\Projects\Thunderhead\2024\CAD\2833-003\2024\PLAT\2833-003-020.dwg LAYOUT NAME: C:\01 DATE: Mar 15, 2024 - 1:25:04 PM CAD OPERATOR: NMM
LIST OF SETS: 2833-003-020-01.dwg, 2833-003-020-02.dwg, 2833-003-020-03.dwg, 2833-003-020-04.dwg, 2833-003-020-05.dwg, 2833-003-020-06.dwg, 2833-003-020-07.dwg, 2833-003-020-08.dwg, 2833-003-020-09.dwg, 2833-003-020-10.dwg, 2833-003-020-11.dwg, 2833-003-020-12.dwg, 2833-003-020-13.dwg, 2833-003-020-14.dwg, 2833-003-020-15.dwg, 2833-003-020-16.dwg, 2833-003-020-17.dwg, 2833-003-020-18.dwg, 2833-003-020-19.dwg, 2833-003-020-20.dwg, 2833-003-020-21.dwg, 2833-003-020-22.dwg, 2833-003-020-23.dwg, 2833-003-020-24.dwg, 2833-003-020-25.dwg, 2833-003-020-26.dwg, 2833-003-020-27.dwg, 2833-003-020-28.dwg, 2833-003-020-29.dwg, 2833-003-020-30.dwg, 2833-003-020-31.dwg, 2833-003-020-32.dwg, 2833-003-020-33.dwg, 2833-003-020-34.dwg, 2833-003-020-35.dwg, 2833-003-020-36.dwg, 2833-003-020-37.dwg, 2833-003-020-38.dwg, 2833-003-020-39.dwg, 2833-003-020-40.dwg, 2833-003-020-41.dwg, 2833-003-020-42.dwg, 2833-003-020-43.dwg, 2833-003-020-44.dwg, 2833-003-020-45.dwg, 2833-003-020-46.dwg, 2833-003-020-47.dwg, 2833-003-020-48.dwg, 2833-003-020-49.dwg, 2833-003-020-50.dwg