



---

Ph: 970-871-6772 · Fax: 970-879-8023 · P.O. Box 775966 · Steamboat Springs, Colorado 80477

# Draft Drainage Study & Water Quality Plan for Copper Ridge Village

Address: 8888 Gloria Gossard Boulevard, Steamboat Springs, CO 80487

Original Draft Drainage Report: 4/15/2021

Revised Drainage Report: 12/2/2021

**Prepared by: Joe Wiedemeier, P.E.  
Four Points Surveying & Engineering**

**P.O. Box 775966  
Steamboat Springs, Colorado 80477  
(970) 871-6772**

---

---

## Table of Contents

<b>1.0 Introduction</b> .....	1
A. Location.....	1
B. Planning Application.....	2
C. Drainage Reports for Adjacent Developments.....	2
D. Stormwater Quality Purpose, Goal, and Special Requirements.....	2
<b>2.0 Drainage Criteria and Methodology Used</b> .....	2
A. Design Rainfall and Storm Frequency .....	2
B. Runoff Calculation Methodology.....	2
C. Culvert and Storm Sewer Design Methodology .....	2
D. Detention Discharge and Storage Methodology .....	3
E. Stormwater Quality Design Standard.....	3
<b>3.0 Existing Conditions</b> .....	3
A. Ground Cover, Imperviousness, Topography and Size.....	3
B. Existing Stormwater Systems.....	3
C. Site Outfall and Ultimate Outfall Locations .....	3
D. Existing System Capacity.....	3
E. NRCS Soil Type.....	4
F. Existing Easements.....	4
G. FEMA Map Reviewal .....	4
<b>4.0 Proposed Conditions</b> .....	4
A. Ground Cover, Imperviousness, Topography and Size.....	4
B. Proposed Stormwater Systems.....	4
C. Outlets: Historic and Proposed Flow .....	5
D. Hydraulic Calculations.....	5
E. Major and Minor Flow Summary Table .....	5
F. Proposed Easements .....	6
G. Off Site Flows .....	6
H. Impacts to Downstream Properties .....	7
I. Potential Site Contaminants.....	7
J. On-Site Stormwater Flows .....	7
K. Detention and Water Quality Design Standard for Volume Based Facilities .....	7
L. Curb and Gutter.....	8

M.	Culverts .....	8
N.	Inlets.....	8
O.	Channels.....	8
P.	Site Discharge .....	9
<b>5.0</b>	<b>Post Construction Stormwater Management.....</b>	<b>9</b>
<b>6.0</b>	<b>Conclusions.....</b>	<b>9</b>
A.	General Summary.....	9
B.	Compliance.....	9
C.	Historic and Proposed Site Flows .....	9
D.	Proposed New Stormwater System Requirements.....	9
<b>7.0</b>	<b>References.....</b>	<b>9</b>
<b>8.0</b>	<b>Appendices.....</b>	<b>10</b>
A.	Existing and Proposed Conditions Drainage Exhibits DR1 & DR2 .....	11
B.	USDA Web Soil Survey.....	12
C.	Basin Runoff Calculations .....	13
D.	PLDP Sizing Calculations for Detention .....	14
E.	Sand Filter Sizing Calculations for Water Quality.....	15
F.	EGL and HGL Stormwater Conveyance Profiles.....	16
G.	Curb and Gutter Calculations.....	17
H.	Culvert Calculations.....	18
I.	Inlet Calculations and Sizing .....	19
J.	Channel Calculations.....	20
K.	Pipe Flow Velocity Table.....	21
L.	Scope Approval Form .....	22
M.	Standard Forms No. 3 & 4 .....	23
N.	Project Sheets for Water Quality.....	24
O.	PLDF Operation and Maintenance Plans (OM1 & OM2) .....	25

NOTE

City of Steamboat Springs plan review and approval is only for general conformance with City design criteria and City code. The City is not responsible for the accuracy and adequacy of the design, dimensions, and elevations that shall be confirmed and correlated at this job site. The City of Steamboat Springs assumes no responsibility for the completeness or accuracy of this document.

CERTIFICATION

I hereby affirm that this Drainage Report for the (name of project) was prepared by me (or under my direct supervision) for the owners thereof and is, to the best of my knowledge, in accordance with the provisions of the City of Steamboat Springs Storm Drainage Criteria and approved variances. I understand that the City of Steamboat Springs does not and will not assume liability for drainage facilities designed by others.

\_\_\_\_\_  
Joe Wiedemeier, P.E.  
State of Colorado No. 0054959  
Date: \_\_\_\_\_

## 1.0 Introduction

This report provides a detailed analysis of the existing and proposed post-development drainage conditions and proposed water quality facilities for the construction of a multi-family residential housing complex Project known as Copper Ridge Village. This report includes all data, engineering methods, assumptions, and calculations used by Four Points Surveying and Engineering (Four Points) to design the stormwater drainage system for the project. Four Points prepared this report and performed engineering calculations for the project in accordance with the most recent version of the City of Steamboat Springs Drainage Criteria and Engineering Standards.

### A. Location

*Figure 1: Vicinity Map – Copper Ridge Subdivision, Lot 1 Steamboat Airpark*



*Source: Google Maps*

The Project site is located on the north side of Gloria Gossard Boulevard, Steamboat Springs, Colorado. The lot shall be platted as: LOT 1 STEAMBOAT AIRPARK. Lot 1 shall be approximately 15.0 acres in size. Existing land use is agricultural/dry land and consists of undeveloped land with native vegetation. Proposed land use is multi-family residential and a portion to be dedicated as open space. A drainage basin approximately 12.5 acres in size is tributary to the project site. Flows congregate at (2) 36" culvert crossings at Gloria Gossard Boulevard designated as design point No. 1.

---

---

## B. Planning Application

This drainage study is for a development plan application for the proposed Project prepared by Four Points Surveying and Engineering on behalf of the owner, developer and project stake holder; Impact Development, LLC.

## C. Drainage Reports for Adjacent Developments

Final Drainage Study for Overlook Park Subdivision prepared by Four Points Surveying and Engineering, March 19, 2020.

Draft Drainage Study prepared by Four Points Surveying and Engineering for the sidewalk extension and improvements along Gloria Gossard Boulevard for the development of West Acres Airpark.

## D. Stormwater Quality Purpose, Goal, and Special Requirements

The purpose of the stormwater quality plan is to design a conveyance and treatment system that fits with the Project and provides both functionality and aesthetics. The goal is to treat surface stormwater runoff per City engineering standards. No special requirements or variances are proposed.

## 2.0 Drainage Criteria and Methodology Used

### A. Design Rainfall and Storm Frequency

Design rainfall: NOAA Atlas 14, Volume 8, Version 2 for Steamboat Springs, CO.

- Minor Event (5-year) 24-hour rainfall depth: 1.59 inches
- Major Event (100-year) 24-hour rainfall depth: 2.91 inches

### B. Runoff Calculation Methodology

Runoff calculation method: Small basin peak flow runoff was analyzed using the Rational Method, shown in Eq-1.

Rational Method:  $Q = CiA$

Where:        Q = runoff, CFS  
                  C = runoff coefficient, dimensionless  
                  i = rainfall intensity, inches per hour  
                  A = basin area, acres

### C. Culvert and Storm Sewer Design Methodology

Sizing calculations for the storm sewer network was performed using AutoCAD HydroFlow Express and AutoCAD HydroFlow Hydrographs which utilizes Manning's "n" equation for open channel flow and the Darcey formula for surcharged flow conditions. Culverts were evaluated under inlet control. The storm sewer conveyance network was modeled with AutoCAD HydroFlow Hydrographs to optimize pipe sizing. The pipe network was analyzed for 100-year flows without overtopping the system. Minimum proposed pipe diameter is 12". Inlet capacities were evaluated with AutoCAD HydroFlow Express based on manufacturer design specifications.

---

---

#### D. Detention Discharge and Storage Methodology

A porous landscape detention facility (PLDF) will provide both detention and water quality in accordance with City drainage standards. The FAA method was used to size the detention facility. Discharge will be regulated with a modified Type C inlet. Orifice plates will manage discharge for the minor and major storm events. An emergency overflow weir will discharge flows exceeding the major event or in the event of the structure or outlet pipe malfunctioning.

#### E. Stormwater Quality Design Standard

The PLDF sand filter area was designed using the Urban Drainage and Flood Control District (UDFCD) Stormwater Best Management Practice Design Workbook UD-BMP (Version 3.07, March 2018). The workbook utilizes impervious area, tributary area, and average runoff producing storm depth for Steamboat Springs to determine water quality capture volume (WQCV) and minimum required flat surface treatment area. The detention volume exceeds the required WQCV and therefore controls the size of the detention facility.

### **3.0 Existing Conditions**

#### A. Ground Cover, Imperviousness, Topography and Size

- Land is undeveloped with native grasses and shrubs.
- 2% imperviousness
- Steep grades exceeding 2:1 (H:V) are present within Lot 1, primarily along the western property line. Moderate gradients ranging from 5-30% draining southerly are present on roughly 50% of the lot. See Existing Conditions Drainage Exhibit, DR1 for additional information.
- Total lot size: 15.0 acres
- Development lot size: 11.1 acres

#### B. Existing Stormwater Systems

No existing drainage infrastructure is located within the Lot 1 property boundaries. Drainage generally sheet flows into a valley or thalweg that bisects Lot 1 where it becomes channelized flow and flows southerly. Flows are concentrated at a 36" existing parallel culvert crossing at Gloria Gossard Boulevard located just south of Lot 1. A 12.0 acre area is tributary to Lot 1 and becomes incorporated in the channelized flow on the north end of Lot 1.

#### C. Site Outfall and Ultimate Outfall Locations

The site generally outfalls into a low lying area on the north side of Gloria Gossard and flows across Gloria Gossard via (2) existing parallel 36" CMP culverts that outfalls into a drainage ditch and eventually flows to the Yampa River.

#### D. Existing System Capacity

Existing system capacity was not evaluated as there is no notable drainage infrastructure within Lot 1 and the proposed detention facility will decrease existing peak flows tributary to the existing parallel 36" culvert crossing.

#### E. NRCS Soil Type

An NRCS Web Soil Survey was performed to determine basic soil characteristics in Lot 1. Soil types include:

- Impass Silty Clay Loam → Hydrologic Soil Group Rating: C
- Eckmanpark Clay Loam → Hydrologic Soil Group Rating: C/D

#### F. Existing Easements

A 40' wide construction and slope maintenance easement and pocket utility easement along the southern property boundary and an aviation easement on the north side of Lot 1. See the Existing Conditions Drainage Exhibit, DR1.

#### G. FEMA Map Reviewal

FEMA flood map No. 08107C0713D was reviewed. Lot 1 is located in Zone X, area of minimal flood hazard.

### **4.0 Proposed Conditions**

#### A. Ground Cover, Imperviousness, Topography and Size

- Total area of development is approximately 11.1 acres.
- Final ground cover will consist primarily of asphalt & concrete paving, multi-family buildings, and landscaping.
- Impervious area: 44%
- Area to be detained and treated: 8.9 acres
- Impervious area to be detained and treated: 3.9 acres
- Percent of developed area to be detained and treated: 80%
- Justification for treating less than the total site area.
  - o The first 100' of access into Lot 1 from Gloria Gossard (part of SB1 & SB20) is lower than the PLDF and cannot practically be collected for detention and treatment. The existing 40' wide construction and slope maintenance easement along the south property line limits how low the permanent treatment facility can be constructed.
  - o Developed slopes (part of SB20 & DB2) shed away from the stormwater collection network. These slopes will be fully vegetated and will be hydraulically and environmentally similar to existing conditions when finished.
  - o The emergency access to the north of the Project site lies primarily within EB3. Flows from this basin will be bypassed through the site and outfall to the south of the site. These flows would be very difficult to separate from the rest of the flows originating from EB3. In addition, the emergency access will be gravel and will not be used except for plowing and in the event of an emergency and the developed slopes will be fully vegetated when finished. This does not pose a significant change to peak flows and water quality shedding from this area.

#### B. Proposed Stormwater Systems

Runoff from the paved surfaces, rooftops, and landscaped areas will be conveyed into ditches, pans, and catch curbs that will flow into a series of inlets and culverts as part of the stormwater collection network. The private stormwater collection network will primarily consist of

---

---

Nyloplast combination curb inlets and area inlets connected via smooth wall PVC or HDEP stormwater pipe. Any public stormwater infrastructure shall meet CDOT specifications and any inlets shall be precast Denver Type 13 or 16. The minimum proposed pipe size is 12” and the largest pipe size is 24” in diameter.

Energy grades lines (EGL) and hydraulic grade lines (HGL) were developed for each run of storm sewer to analyze surcharging conditions under the minor and major event flows. The stormwater collection network was designed to handle the minor event without surcharging the system, and will effectively convey the major event without overflowing the inlets. See Appendix for EGL and HGL stormwater conveyance profiles in Appendix F.

Pipe velocities were analyzed for standards conformance. Storm sewer velocities were analyzed for the 1.25-year design event, the minor event, and the major event. Pipe velocity was found to generally be within the required standards. See Appendix K for a summary table of pipe flow velocities.

#### C. Outlets: Historic and Proposed Flow

The historic outlet point from Lot 1 occurs at design point No. 2 as shown on the existing conditions drainage plan. The PLDF stormwater outlet is located at design point No 2.

#### D. Hydraulic Calculations

Hydraulic calculations were performed for the stormwater inlets, conveyance piping, and drainage swales. Calculations were performed using AutoCAD Hydroflow Express software. The calculations utilize manning’s n equation for open channel flow and the Darcey formula for surcharged flow conditions.

#### E. Major and Minor Flow Summary Table

The existing and proposed drainage was analyzed by subdividing the contributing drainage area into existing basins (EB), developed basins (DB) and sub-basins (SB). Major and minor flows for each basin is summarized in the following table.

*Table 1: Major and Minor Flow Summary Table*

Basin ID	Area (acres)	Impervious Area (%)	Runoff	
			Q <sub>5</sub> (cfs)	Q <sub>100</sub> (cfs)
<b>EB1</b>	9.96	2%	3.12	21.25
<b>EB2</b>	5.06	2%	2.53	17.22
<b>EB3</b>	12.50	2%	2.86	19.54
<b>EB4</b>	0.93	2%	0.44	3.02
<b>EB5</b>	1.82	14%	1.11	5.63
<b>DB1</b>	8.31	44%	7.07	24.89
<b>DB2</b>	4.30	2%	2.23	15.19
<b>DB3</b>	1.82	24%	1.32	5.81

---

<b>SB1</b>	0.96	5%	0.54	3.37
<b>SB2</b>	0.12	2%	0.07	0.50
<b>SB3</b>	0.34	2%	0.16	1.06
<b>SB4</b>	0.12	2%	0.05	0.35
<b>SB5</b>	0.87	2%	0.34	2.32
<b>SB6</b>	0.08	51%	0.12	0.39
<b>SB7</b>	0.26	2%	0.16	1.08
<b>SB8</b>	0.07	58%	0.12	0.36
<b>SB9</b>	0.33	91%	0.86	2.09
<b>SB10</b>	0.40	2%	0.23	1.54
<b>SB11</b>	0.56	80%	1.13	2.94
<b>SB12</b>	0.18	55%	0.27	0.84
<b>SB13</b>	0.26	51%	0.37	1.21
<b>SB14</b>	0.04	2%	0.02	0.15
<b>SB15</b>	0.18	56%	0.25	0.77
<b>SB16</b>	0.34	2%	0.20	1.34
<b>SB17</b>	0.91	19%	0.73	3.42
<b>SB18</b>	0.16	51%	0.22	0.71
<b>SB19</b>	0.48	63%	0.71	2.11
<b>SB20</b>	1.27	6%	0.88	5.38
<b>SB21</b>	0.55	76%	1.05	2.81
<b>SB22</b>	0.16	82%	0.35	0.91
<b>SB23</b>	0.86	45%	0.96	3.34
<b>SB24</b>	0.48	50%	0.62	2.06
<b>SB25</b>	0.03	67%	0.06	0.16
<b>SB26</b>	0.25	61%	0.43	1.30
<b>SB27</b>	0.57	77%	1.22	3.24
<b>SB28</b>	0.02	100%	0.07	0.16
<b>SB29</b>	0.15	15%	0.08	0.39
<b>SB30</b>	0.53	68%	0.78	2.21

#### F. Proposed Easements

A drainage easement is proposed for the PLDF.

#### G. Off Site Flows

- Flow from EB3 will be routed through Lot 1 via 24” smooth wall HDPE pipe and discharged into the historic flow path just south of Lot 1.
  - Flow from SB2 will enter Lot 1 and will not be treated or detained.
-

- Flows from SB3 and SB4 will enter Lot 1 and will be treated and detained.

#### H. Impacts to Downstream Properties

There are no anticipated impacts to downstream properties from the proposed development.

#### I. Potential Site Contaminants

- Sediment, sand, and grit
- Vehicular pollutants (oils, antifreeze, carbon deposits, heavy metals, etc.)
- Fertilizers and other lawn care chemicals.

#### J. On-Site Stormwater Flows

On site flows will originate primarily from paved surfaces, rooftops, and landscaped areas. Flows will be managed as designed in the Grading and Drainage Plan. Flows will be detained and treated by the PLDF.

#### K. Detention and Water Quality Design Standard for Volume Based Facilities

The FAA routing method was used to size the PLDF. The Denver UDFCD WQCV design standard was used to size the sand filter area. Table 2 summarizes the design variables.

*Table 2: PLDF Design Variables*

<b><u>PLDF Design Variables</u></b>	<b><u>Design Value</u></b>
Detention Design Standard	FAA
Water Quality Design Standard	WQCV
Area Treated (acres)	8.9
Imperviousness of Area Treated	44%
C Values of Area Treated	0.59
Hydrologic Soil Types of Treatment Area	C
WQCV (watershed inches)	0.15
WQCV Design Volume (ft <sup>3</sup> )	3,863
Total Pond Depth (ft)	5.0
Total Pond Area (ft <sup>2</sup> )	7,700
Total Storage Volume (ft <sup>3</sup> )	20,700
Design Treatment Area (ft <sup>2</sup> )	2,118

---



---

Table 2 continued

Total Flat Treatment Area (ft <sup>2</sup> )	2,120
Outlet	Type C Inlet
Overflow	Weir
1.25 Year Peak Release Rate for Water Quality (cfs)	0.46
Minor Event Peak Release Rate (cfs)	0.65
Major Event Peak Release Rate (cfs)	0.97

- Outfall Design:
  - o Primary Outfall: 12” HDPE or PVC pipe into a scour protection apron.
  - o Emergency Overflow: 5’ wide, 1’ high weir into a scour protected outfall.
- Maintenance Requirements: See O&M Plans (WQ1 & WQ2)

#### L. Curb and Gutter

Spill curbs and catch curbs shall manage concentrated flow conveyance from parking areas and roads throughout the paved portions of the site. Curb and gutter capacity was evaluated at design point No. 5. This section of curb and gutter will receive the highest peak flows.

#### M. Culverts

Culvert crossings and stormwater crossings are proposed at multiple locations. Stormwater crossings at private roads were evaluated as a culvert crossing condition. Culvert crossings were evaluated at design points No. 7 and No. 8. These crossings will receive the highest peak flows for private road crossings on the site. Outlet protection is required at the outfalls. An appropriately sized rip-rap shall be used.

#### N. Inlets

Nyloplast combination curb inlets and area inlets with standard grates are proposed to collect stormwater flows from gutters, ditches, and valley pans throughout the site. Each proposed combination curb inlet has the capacity to capture the minor storm event with 100% efficiency. Capacity was evaluated at design points No. 9 and No. 10. These inlets will receive the highest peak flows on site. Design point No. 9 inlet captures the minor and major storm events at 100% capacity. Design point No. 10 inlet captures the minor and major storm events at 100% capacity and 93% capacity, respectively.

Within the public right-of-way (i.e. the access intersection at Gloria Gossard), Denver Type 13 and Denver Type 16 precast inlets shall be required. Inlets installed within the public right-of-way shall meet CDOT specifications.

#### O. Channels

Drainage ditches and concrete valley pans will be used to manage concentrated flow conveyance from parking areas and roads throughout the paved portions of the site. Ditch capacity was evaluated at design point No. 4. This section of proposed ditch will receive the highest peak

flows from sub-basins SB17 through SB29. Concrete valley pan capacity was evaluated at design point No. 6. This section of proposed concrete valley pan will receive the highest peak flows from SB26.

#### P. Site Discharge

The PLDF will detain stormwater runoff for peak flows up to the major event. It will release flows less than that of the historic flow rates at design point No. 1 and No. 2 due to the design of the outlet structure and orifice plate on the outfall pipe. The existing parallel 36” culvert crossing at Gloria Gossard was not evaluated for capacity but existing peak flows were calculated that are tributary to it. The proposed development will not increase peak flows at this critical design point (design point No. 1).

### **5.0 Post Construction Stormwater Management**

The PLDF and inlets with 2’ deep sumps will be the primary permanent BMP practices used to control pollutant and sediment discharge. See Operation and Maintenance Plans, OM1 & OM2 for additional information.

### **6.0 Conclusions**

#### A. General Summary

Existing drainage patterns will generally be maintained under the proposed conditions. The historic outfall points will be maintained. The proposed drainage for the Project includes a combination of curb and gutter, valley pans, inlets, stormwater piping, culverts and ditches to convey minor and major event flows to the PLDF. Treated stormwater will be discharged into the historic outfall point.

#### B. Compliance

The proposed stormwater drainage system complies with City Drainage Criteria. No drainage related variances to the engineering Criteria or Standards are requested.

#### C. Historic and Proposed Site Flows

Peak proposed flow will be less than peak historic flows from the Project site. The drainage associated with the Project will not have an adverse impact on adjacent or downstream properties.

#### D. Proposed New Stormwater System Requirements

The new stormwater system will need to be maintained periodically and as needed to ensure the system functions and operates as is was designed.

### **7.0 References**

*Urban Drainage and Flood Control District Criteria Manual, 2018.*

*NOAA Precipitation Frequency Server. NOAA Atlas 14, Volume 8, Version 2. [www.NOAA.com](http://www.NOAA.com)*

---

---

*City of Steamboat Springs Engineering Drainage Criteria, Latest Version.*

**8.0 Appendices**

Can be found on the following pages.

A. Existing and Proposed Conditions Drainage Exhibits DR1 & DR2

INT	REVISIONS	DATE	No.

STEAMBOAT AIRPARK APARTMENTS  
XXXXXX.  
STEAMBOAT SPRINGS, CO 80487

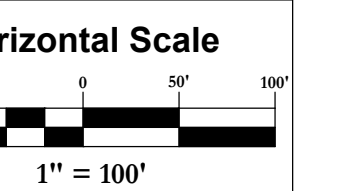

Contour Interval = 2 ft

DATE: 4/9/2021  
JOB #: 4/9/2021  
DRAWN BY: JLW  
DESIGN BY: JLW  
REVIEW BY: RL

IF THIS DRAWING IS PRESENTED IN A FORMAT OTHER THAN 24" X 36" THE GRAPHIC SCALE SHOULD BE UTILIZED.

DRAWING:  
EXISTING  
CONDITIONS  
DRAINAGE

SHEET #

DR1

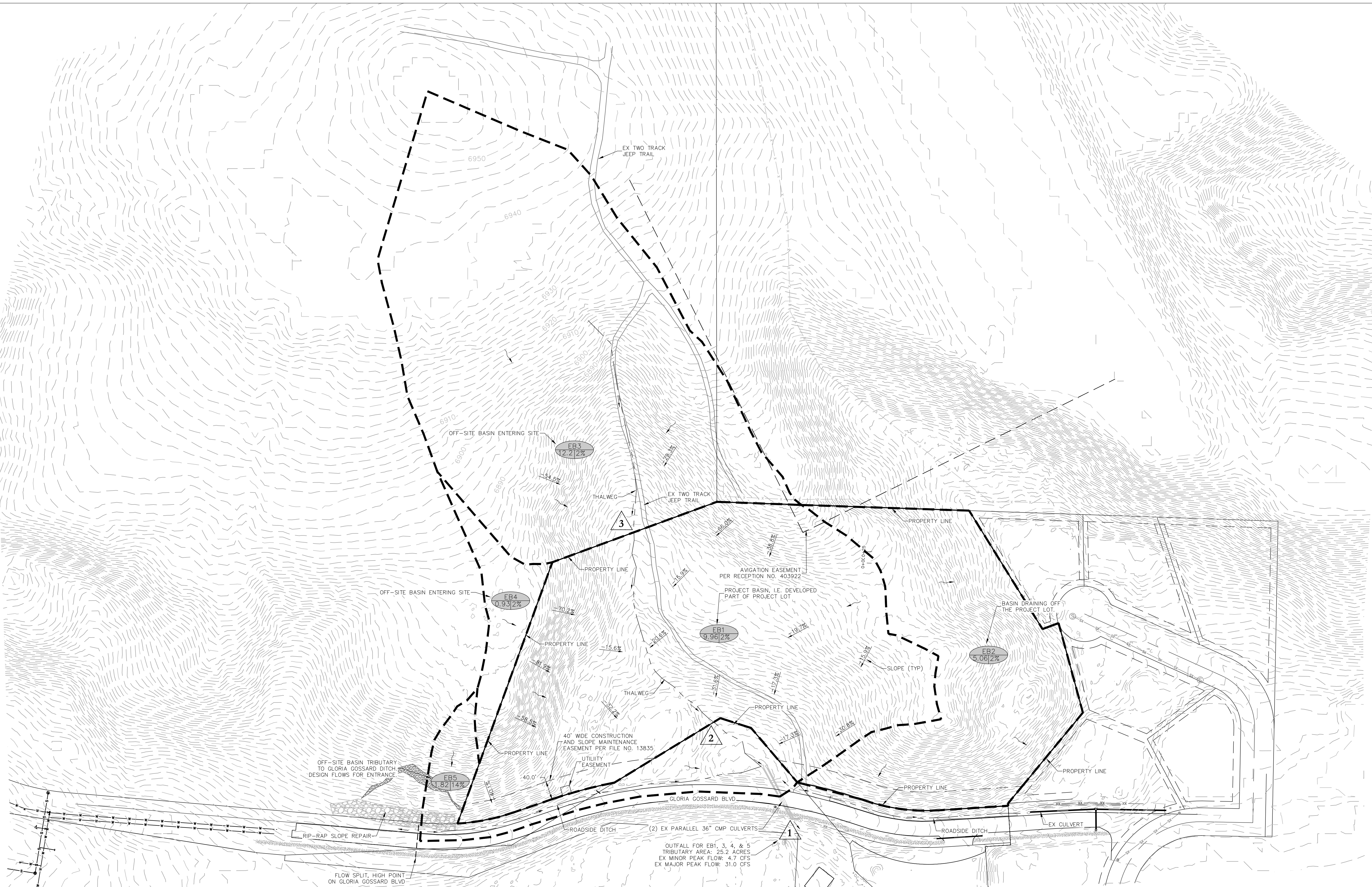

DRAINAGE PLAN LEGEND

- EXISTING BASIN BOUNDARY
- FLOW PATH, SHEET FLOW
- FLOW PATH, CONCENTRATED
- HIGH OR LOW POINT IN PAVING POINT
- DESIGN POINT DESIGNATION
- A: BASIN DESIGNATION  
B: BASIN AREA (ACRES)  
C: % IMPERVIOUS
- UNTREATED/UNDETAINED DEVELOPED AREA

DESIGN POINTS:

1. OUTFALL FOR EXISTING BASINS (EB) EB1, EB3, EB4, & EB5
2. OUTFALL FOR EB1, EB3, & EB4
3. OUTFALL FOR EB3 (PASS THROUGH BASIN FOR DEVELOPMENT)

OUTFALL FOR EB1, 3, 4, & 5  
TRIBUTARY AREA: 25.2 ACRES  
EX MINOR PEAK FLOW: 4.7 CFS  
EX MAJOR PEAK FLOW: 31.0 CFS

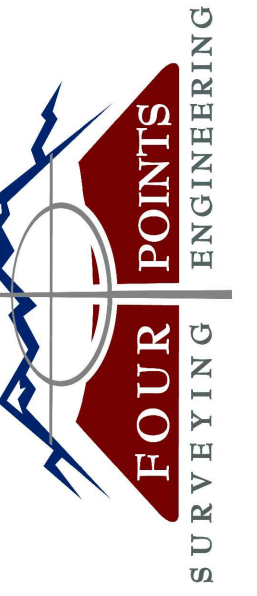

440 S. Lincoln Ave, Suite 4A  
 P.O. Box 775966  
 Steamboat Springs, CO 80487  
 (970)-871-6772  
 www.fourpointse.com

No.	DATE	REVISIONS	MINOR SITE WIDE DRAINAGE	
			INT	JLW
1	12/2/21			

**COPPER RIDGE APARTMENTS**  
**8888 GLORIA GOSSARD**  
**STEAMBOAT SPRINGS, CO 80487**

Horizontal Scale  
  
 1" = 50'

Contour Interval = 2 ft

DATE: 4/9/2021  
 JOB #: 4/9/2021  
 DRAWN BY: JLW  
 DESIGN BY: JLW  
 REVIEW BY: RL/MDM

IF THIS DRAWING IS PRESENTED IN A  
 FORMAT OTHER THAN A4 X 36", THE  
 GRAPHIC SCALE SHOULD BE UTILIZED.

**PROPOSED  
 CONDITIONS  
 DRAINAGE**

DRAWING:

SHEET #

**DR2**

- DRAINAGE PLAN LEGEND**
- EXISTING & DEVELOPED BASIN BOUNDARY
  - - - SUB-BASIN BOUNDARY
  - ~ FLOW PATH, SHEET FLOW
  - FLOW PATH, CONCENTRATED
  - HIGH OR LOW POINT IN PAVING
  - △ DESIGN POINT DESIGNATION
  - A: BASIN DESIGNATION  
 ○ B: BASIN AREA (ACRES)  
 ○ C: % IMPERVIOUS
  - ▨ UNTREATED/UNDETAINED DEVELOPED AREA

**BASIN ANNOTATIONS**

- EB EXISTING BASIN
- DB DEVELOPED BASIN
- SB SUB-BASIN

**DESIGN POINTS:**

1. OUTFALL FOR EB3, DB1, DB3, SB1, & SB20
2. OUTFALL FOR EB3 & DB1
3. OUTFALL FOR EB3 (PASS THROUGH FLOWS)
4. DITCH DESIGN POINT
5. CURB & GUTTER DESIGN POINT
6. VALLEY PAN DESIGN POINT
7. CULVERT CROSSING DESIGN POINT
8. CULVERT CROSSING DESIGN POINT
9. COMBINATION CURB INLET DESIGN POINT
10. COMBINATION CURB INLET DESIGN POINT

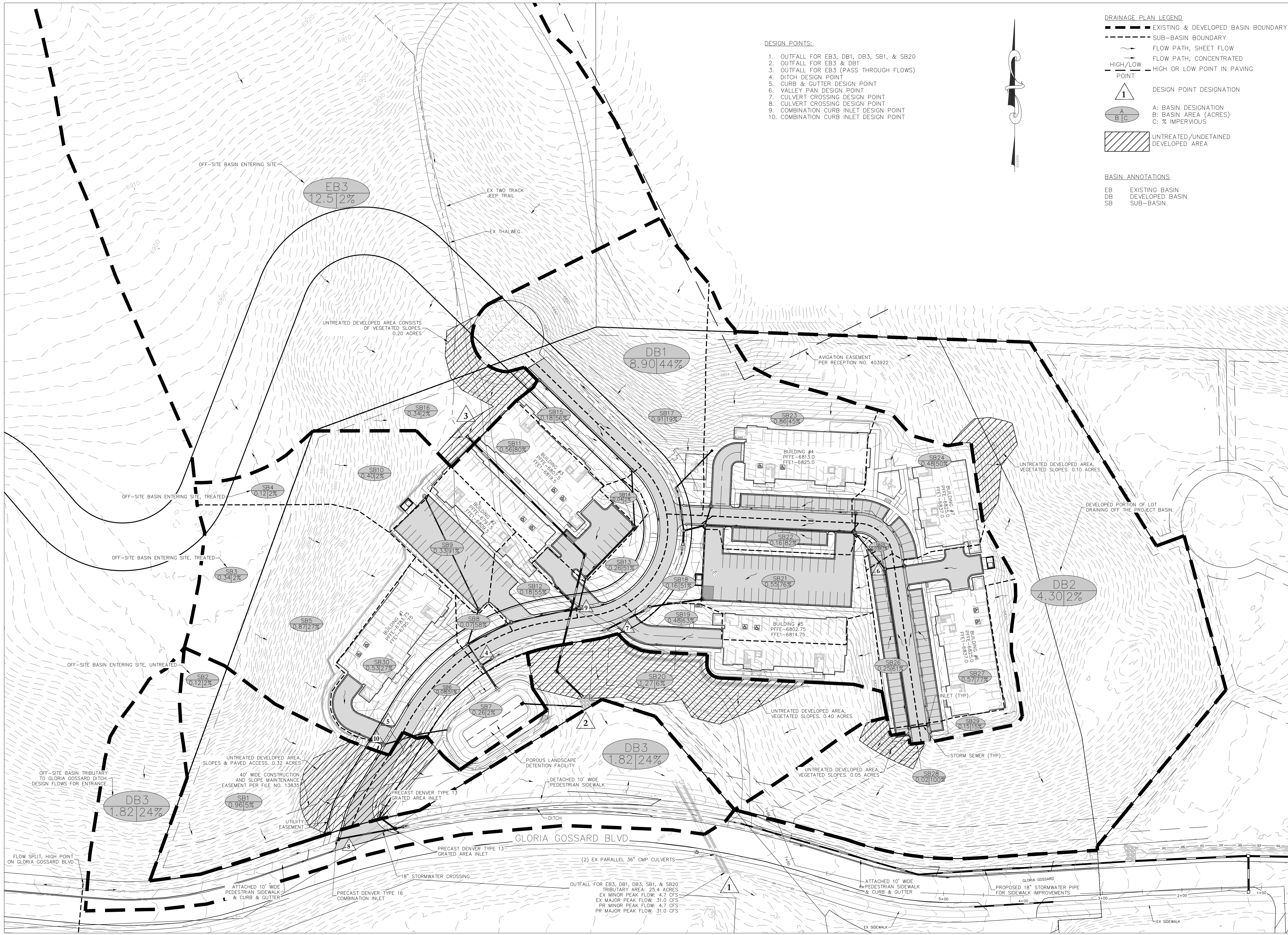

OUTFALL FOR EB3, DB1, DB3, SB1, & SB20  
 TRIBUTARY AREA: 25.4 ACRES  
 EX MINOR PEAK FLOW: 4.7 CFS  
 EX MAJOR PEAK FLOW: 31.0 CFS  
 PR MINOR PEAK FLOW: 4.7 CFS  
 PR MAJOR PEAK FLOW: 31.0 CFS

FLOW SPLIT, HIGH POINT  
 ON GLORIA GOSSARD BLVD

OFF-SITE BASIN TRIBUTARY  
 TO GLORIA GOSSARD DITCH,  
 DESIGN FLOWS FOR ENTRANCE

OFF-SITE BASIN ENTERING SITE, UNTREATED

OFF-SITE BASIN ENTERING SITE, TREATED

OFF-SITE BASIN ENTERING SITE, TREATED

OFF-SITE BASIN ENTERING SITE

OFF-SITE BASIN ENTERING SITE

OFF-SITE BASIN ENTERING SITE

UNREATED DEVELOPED AREA,  
 SLOPES & PAVED ACCESS, 0.32 ACRES

UNREATED DEVELOPED AREA,  
 SLOPES & PAVED ACCESS, 0.32 ACRES

UNREATED DEVELOPED AREA,  
 SLOPES & PAVED ACCESS, 0.32 ACRES

UNREATED DEVELOPED AREA,  
 SLOPES & PAVED ACCESS, 0.32 ACRES

UNREATED DEVELOPED AREA,  
 SLOPES & PAVED ACCESS, 0.32 ACRES

UNREATED DEVELOPED AREA,  
 SLOPES & PAVED ACCESS, 0.32 ACRES

UNREATED DEVELOPED AREA,  
 SLOPES & PAVED ACCESS, 0.32 ACRES

UNREATED DEVELOPED AREA,  
 SLOPES & PAVED ACCESS, 0.32 ACRES

UNREATED DEVELOPED AREA,  
 SLOPES & PAVED ACCESS, 0.32 ACRES

UNREATED DEVELOPED AREA,  
 VEGETATED SLOPES, 0.40 ACRES

UNREATED DEVELOPED AREA,  
 VEGETATED SLOPES, 0.40 ACRES

UNREATED DEVELOPED AREA,  
 VEGETATED SLOPES, 0.40 ACRES

UNREATED DEVELOPED AREA,  
 VEGETATED SLOPES, 0.40 ACRES

UNREATED DEVELOPED AREA,  
 VEGETATED SLOPES, 0.40 ACRES

UNREATED DEVELOPED AREA,  
 VEGETATED SLOPES, 0.40 ACRES

UNREATED DEVELOPED AREA,  
 VEGETATED SLOPES, 0.40 ACRES

UNREATED DEVELOPED AREA,  
 VEGETATED SLOPES, 0.40 ACRES

UNREATED DEVELOPED AREA,  
 VEGETATED SLOPES, 0.40 ACRES

UNREATED DEVELOPED AREA,  
 VEGETATED SLOPES, 0.05 ACRES

UNREATED DEVELOPED AREA,  
 VEGETATED SLOPES, 0.05 ACRES

UNREATED DEVELOPED AREA,  
 VEGETATED SLOPES, 0.05 ACRES

UNREATED DEVELOPED AREA,  
 VEGETATED SLOPES, 0.05 ACRES

UNREATED DEVELOPED AREA,  
 VEGETATED SLOPES, 0.05 ACRES

UNREATED DEVELOPED AREA,  
 VEGETATED SLOPES, 0.05 ACRES

UNREATED DEVELOPED AREA,  
 VEGETATED SLOPES, 0.05 ACRES

UNREATED DEVELOPED AREA,  
 VEGETATED SLOPES, 0.05 ACRES

UNREATED DEVELOPED AREA,  
 VEGETATED SLOPES, 0.05 ACRES

UNREATED DEVELOPED AREA,  
 VEGETATED SLOPES, 0.10 ACRES

UNREATED DEVELOPED AREA,  
 VEGETATED SLOPES, 0.10 ACRES

UNREATED DEVELOPED AREA,  
 VEGETATED SLOPES, 0.10 ACRES

UNREATED DEVELOPED AREA,  
 VEGETATED SLOPES, 0.10 ACRES

UNREATED DEVELOPED AREA,  
 VEGETATED SLOPES, 0.10 ACRES

UNREATED DEVELOPED AREA,  
 VEGETATED SLOPES, 0.10 ACRES

UNREATED DEVELOPED AREA,  
 VEGETATED SLOPES, 0.10 ACRES

UNREATED DEVELOPED AREA,  
 VEGETATED SLOPES, 0.10 ACRES

UNREATED DEVELOPED AREA,  
 VEGETATED SLOPES, 0.10 ACRES

UNREATED DEVELOPED AREA,  
 VEGETATED SLOPES, 0.20 ACRES

UNREATED DEVELOPED AREA,  
 VEGETATED SLOPES, 0.20 ACRES

UNREATED DEVELOPED AREA,  
 VEGETATED SLOPES, 0.20 ACRES

UNREATED DEVELOPED AREA,  
 VEGETATED SLOPES, 0.20 ACRES

UNREATED DEVELOPED AREA,  
 VEGETATED SLOPES, 0.20 ACRES

UNREATED DEVELOPED AREA,  
 VEGETATED SLOPES, 0.20 ACRES

UNREATED DEVELOPED AREA,  
 VEGETATED SLOPES, 0.20 ACRES

UNREATED DEVELOPED AREA,  
 VEGETATED SLOPES, 0.20 ACRES

UNREATED DEVELOPED AREA,  
 VEGETATED SLOPES, 0.20 ACRES

UNREATED DEVELOPED AREA,  
 VEGETATED SLOPES, 0.20 ACRES

UNREATED DEVELOPED AREA,  
 VEGETATED SLOPES, 0.20 ACRES

UNREATED DEVELOPED AREA,  
 VEGETATED SLOPES, 0.20 ACRES

UNREATED DEVELOPED AREA,  
 VEGETATED SLOPES, 0.20 ACRES

UNREATED DEVELOPED AREA,  
 VEGETATED SLOPES, 0.20 ACRES

UNREATED DEVELOPED AREA,  
 VEGETATED SLOPES, 0.20 ACRES

UNREATED DEVELOPED AREA,  
 VEGETATED SLOPES, 0.20 ACRES

UNREATED DEVELOPED AREA,  
 VEGETATED SLOPES, 0.20 ACRES

UNREATED DEVELOPED AREA,  
 VEGETATED SLOPES, 0.20 ACRES

UNREATED DEVELOPED AREA,  
 VEGETATED SLOPES, 0.20 ACRES

UNREATED DEVELOPED AREA,  
 VEGETATED SLOPES, 0.20 ACRES

UNREATED DEVELOPED AREA,  
 VEGETATED SLOPES, 0.20 ACRES

UNREATED DEVELOPED AREA,  
 VEGETATED SLOPES, 0.20 ACRES

UNREATED DEVELOPED AREA,  
 VEGETATED SLOPES, 0.20 ACRES

UNREATED DEVELOPED AREA,  
 VEGETATED SLOPES, 0.20 ACRES

UNREATED DEVELOPED AREA,  
 VEGETATED SLOPES, 0.20 ACRES

UNREATED DEVELOPED AREA,  
 VEGETATED SLOPES, 0.20 ACRES

UNREATED DEVELOPED AREA,  
 VEGETATED SLOPES, 0.20 ACRES

UNREATED DEVELOPED AREA,  
 VEGETATED SLOPES, 0.20 ACRES

UNREATED DEVELOPED AREA,  
 VEGETATED SLOPES, 0.20 ACRES

UNREATED DEVELOPED AREA,  
 VEGETATED SLOPES, 0.20 ACRES

UNREATED DEVELOPED AREA,  
 VEGETATED SLOPES, 0.20 ACRES

UNREATED DEVELOPED AREA,  
 VEGETATED SLOPES, 0.20 ACRES

UNREATED DEVELOPED AREA,  
 VEGETATED SLOPES, 0.20 ACRES

UNREATED DEVELOPED AREA,  
 VEGETATED SLOPES, 0.20 ACRES

UNREATED DEVELOPED AREA,  
 VEGETATED SLOPES, 0.20 ACRES

UNREATED DEVELOPED AREA,  
 VEGETATED SLOPES, 0.20 ACRES

UNREATED DEVELOPED AREA,  
 VEGETATED SLOPES, 0.20 ACRES

UNREATED DEVELOPED AREA,  
 VEGETATED SLOPES, 0.20 ACRES

UNREATED DEVELOPED AREA,  
 VEGETATED SLOPES, 0.20 ACRES

UNREATED DEVELOPED AREA,  
 VEGETATED SLOPES, 0.20 ACRES

UNREATED DEVELOPED AREA,  
 VEGETATED SLOPES, 0.20 ACRES

UNREATED DEVELOPED AREA,  
 VEGETATED SLOPES, 0.20 ACRES

UNREATED DEVELOPED AREA,  
 VEGETATED SLOPES, 0.20 ACRES

UNREATED DEVELOPED AREA,  
 VEGETATED SLOPES, 0.20 ACRES

UNREATED DEVELOPED AREA,  
 VEGETATED SLOPES, 0.20 ACRES

B. USDA Web Soil Survey



United States  
Department of  
Agriculture

**NRCS**

Natural  
Resources  
Conservation  
Service

A product of the National  
Cooperative Soil Survey,  
a joint effort of the United  
States Department of  
Agriculture and other  
Federal agencies, State  
agencies including the  
Agricultural Experiment  
Stations, and local  
participants

# Custom Soil Resource Report for Routt Area, Colorado, Parts of Rio Blanco and Routt Counties



# Custom Soil Resource Report Soil Map

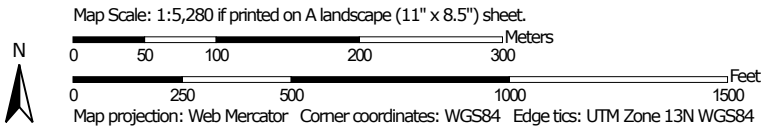



### MAP LEGEND

**Area of Interest (AOI)**

 Area of Interest (AOI)



















**Soils**







 Soil Map Unit Polygons

 Soil Map Unit Lines

 Soil Map Unit Points

**Special Point Features**





-  Blowout
-  Borrow Pit
-  Clay Spot
-  Closed Depression
-  Gravel Pit
-  Gravelly Spot
-  Landfill
-  Lava Flow
-  Marsh or swamp
-  Mine or Quarry
-  Miscellaneous Water
-  Perennial Water
-  Rock Outcrop
-  Saline Spot
-  Sandy Spot
-  Severely Eroded Spot
-  Sinkhole
-  Slide or Slip
-  Sodic Spot

-  Spoil Area
-  Stony Spot
-  Very Stony Spot
-  Wet Spot
-  Other
-  Special Line Features

**Water Features**

 Streams and Canals

**Transportation**

-  Rails
-  Interstate Highways
-  US Routes
-  Major Roads
-  Local Roads

**Background**

 Aerial Photography

### MAP INFORMATION

The soil surveys that comprise your AOI were mapped at 1:24,000.

Warning: Soil Map may not be valid at this scale.

Enlargement of maps beyond the scale of mapping can cause misunderstanding of the detail of mapping and accuracy of soil line placement. The maps do not show the small areas of contrasting soils that could have been shown at a more detailed scale.

Please rely on the bar scale on each map sheet for map measurements.

Source of Map: Natural Resources Conservation Service  
 Web Soil Survey URL:  
 Coordinate System: Web Mercator (EPSG:3857)

Maps from the Web Soil Survey are based on the Web Mercator projection, which preserves direction and shape but distorts distance and area. A projection that preserves area, such as the Albers equal-area conic projection, should be used if more accurate calculations of distance or area are required.

This product is generated from the USDA-NRCS certified data as of the version date(s) listed below.

Soil Survey Area: Routt Area, Colorado, Parts of Rio Blanco and Routt Counties  
 Survey Area Data: Version 10, Jun 5, 2020

Soil map units are labeled (as space allows) for map scales 1:50,000 or larger.

Date(s) aerial images were photographed: May 8, 2012—Oct 5, 2017

The orthophoto or other base map on which the soil lines were compiled and digitized probably differs from the background

## Map Unit Legend

Map Unit Symbol	Map Unit Name	Acres in AOI	Percent of AOI
89	Eckmanpark clay, 6 to 25 percent slopes	34.0	33.7%
120	Eckmanpark clay loam, 25 to 65 percent slopes	47.9	47.4%
C10	Impass silty clay loam, 3 to 12 percent slopes	19.1	18.9%
<b>Totals for Area of Interest</b>		<b>101.0</b>	<b>100.0%</b>

## Map Unit Descriptions

The map units delineated on the detailed soil maps in a soil survey represent the soils or miscellaneous areas in the survey area. The map unit descriptions, along with the maps, can be used to determine the composition and properties of a unit.

A map unit delineation on a soil map represents an area dominated by one or more major kinds of soil or miscellaneous areas. A map unit is identified and named according to the taxonomic classification of the dominant soils. Within a taxonomic class there are precisely defined limits for the properties of the soils. On the landscape, however, the soils are natural phenomena, and they have the characteristic variability of all natural phenomena. Thus, the range of some observed properties may extend beyond the limits defined for a taxonomic class. Areas of soils of a single taxonomic class rarely, if ever, can be mapped without including areas of other taxonomic classes. Consequently, every map unit is made up of the soils or miscellaneous areas for which it is named and some minor components that belong to taxonomic classes other than those of the major soils.

Most minor soils have properties similar to those of the dominant soil or soils in the map unit, and thus they do not affect use and management. These are called noncontrasting, or similar, components. They may or may not be mentioned in a particular map unit description. Other minor components, however, have properties and behavioral characteristics divergent enough to affect use or to require different management. These are called contrasting, or dissimilar, components. They generally are in small areas and could not be mapped separately because of the scale used. Some small areas of strongly contrasting soils or miscellaneous areas are identified by a special symbol on the maps. If included in the database for a given area, the contrasting minor components are identified in the map unit descriptions along with some characteristics of each. A few areas of minor components may not have been observed, and consequently they are not mentioned in the descriptions, especially where the pattern was so complex that it was impractical to make enough observations to identify all the soils and miscellaneous areas on the landscape.

The presence of minor components in a map unit in no way diminishes the usefulness or accuracy of the data. The objective of mapping is not to delineate pure taxonomic classes but rather to separate the landscape into landforms or

## Custom Soil Resource Report

landform segments that have similar use and management requirements. The delineation of such segments on the map provides sufficient information for the development of resource plans. If intensive use of small areas is planned, however, onsite investigation is needed to define and locate the soils and miscellaneous areas.

An identifying symbol precedes the map unit name in the map unit descriptions. Each description includes general facts about the unit and gives important soil properties and qualities.

Soils that have profiles that are almost alike make up a *soil series*. Except for differences in texture of the surface layer, all the soils of a series have major horizons that are similar in composition, thickness, and arrangement.

Soils of one series can differ in texture of the surface layer, slope, stoniness, salinity, degree of erosion, and other characteristics that affect their use. On the basis of such differences, a soil series is divided into *soil phases*. Most of the areas shown on the detailed soil maps are phases of soil series. The name of a soil phase commonly indicates a feature that affects use or management. For example, Alpha silt loam, 0 to 2 percent slopes, is a phase of the Alpha series.

Some map units are made up of two or more major soils or miscellaneous areas. These map units are complexes, associations, or undifferentiated groups.

A *complex* consists of two or more soils or miscellaneous areas in such an intricate pattern or in such small areas that they cannot be shown separately on the maps. The pattern and proportion of the soils or miscellaneous areas are somewhat similar in all areas. Alpha-Beta complex, 0 to 6 percent slopes, is an example.

An *association* is made up of two or more geographically associated soils or miscellaneous areas that are shown as one unit on the maps. Because of present or anticipated uses of the map units in the survey area, it was not considered practical or necessary to map the soils or miscellaneous areas separately. The pattern and relative proportion of the soils or miscellaneous areas are somewhat similar. Alpha-Beta association, 0 to 2 percent slopes, is an example.

An *undifferentiated group* is made up of two or more soils or miscellaneous areas that could be mapped individually but are mapped as one unit because similar interpretations can be made for use and management. The pattern and proportion of the soils or miscellaneous areas in a mapped area are not uniform. An area can be made up of only one of the major soils or miscellaneous areas, or it can be made up of all of them. Alpha and Beta soils, 0 to 2 percent slopes, is an example.

Some surveys include *miscellaneous areas*. Such areas have little or no soil material and support little or no vegetation. Rock outcrop is an example.

## Routt Area, Colorado, Parts of Rio Blanco and Routt Counties

### 89—Eckmanpark clay, 6 to 25 percent slopes

#### Map Unit Setting

*National map unit symbol:* k0ht  
*Elevation:* 6,560 to 8,530 feet  
*Mean annual precipitation:* 20 to 24 inches  
*Mean annual air temperature:* 38 to 41 degrees F  
*Frost-free period:* 30 to 70 days  
*Farmland classification:* Not prime farmland

#### Map Unit Composition

*Eckmanpark and similar soils:* 100 percent  
*Estimates are based on observations, descriptions, and transects of the mapunit.*

#### Description of Eckmanpark

##### Setting

*Landform:* Hills  
*Landform position (two-dimensional):* Backslope  
*Landform position (three-dimensional):* Side slope  
*Down-slope shape:* Linear  
*Across-slope shape:* Linear  
*Parent material:* Slope alluvium and/or colluvium over residuum weathered from shale

##### Typical profile

*A - 0 to 2 inches:* clay  
*Bss1 - 2 to 9 inches:* clay  
*Bss2 - 9 to 17 inches:* clay  
*Bk - 17 to 32 inches:* clay  
*Cr - 32 to 36 inches:* bedrock

##### Properties and qualities

*Slope:* 6 to 25 percent  
*Depth to restrictive feature:* 28 to 37 inches to paralithic bedrock  
*Drainage class:* Well drained  
*Runoff class:* Medium  
*Capacity of the most limiting layer to transmit water (Ksat):* Low to moderately high  
(0.00 to 0.21 in/hr)  
*Depth to water table:* More than 80 inches  
*Frequency of flooding:* None  
*Frequency of ponding:* None  
*Calcium carbonate, maximum content:* 15 percent  
*Gypsum, maximum content:* 2 percent  
*Maximum salinity:* Nonsaline to very slightly saline (0.0 to 2.0 mmhos/cm)  
*Available water capacity:* Low (about 5.4 inches)

##### Interpretive groups

*Land capability classification (irrigated):* 6e  
*Land capability classification (nonirrigated):* 6e  
*Hydrologic Soil Group:* D  
*Ecological site:* R048AY244CO  
*Hydric soil rating:* No

## 120—Eckmanpark clay loam, 25 to 65 percent slopes

### Map Unit Setting

*National map unit symbol:* k0jp  
*Elevation:* 6,560 to 8,690 feet  
*Mean annual precipitation:* 20 to 24 inches  
*Mean annual air temperature:* 38 to 41 degrees F  
*Frost-free period:* 30 to 70 days  
*Farmland classification:* Not prime farmland

### Map Unit Composition

*Eckmanpark and similar soils:* 95 percent  
*Minor components:* 5 percent  
*Estimates are based on observations, descriptions, and transects of the mapunit.*

### Description of Eckmanpark

#### Setting

*Landform:* Hills  
*Landform position (two-dimensional):* Backslope  
*Landform position (three-dimensional):* Side slope  
*Down-slope shape:* Linear  
*Across-slope shape:* Concave  
*Parent material:* Colluvium over residuum weathered from shale

#### Typical profile

*A - 0 to 1 inches:* clay loam  
*Bss - 1 to 10 inches:* clay  
*Bk - 10 to 26 inches:* clay  
*Cr - 26 to 35 inches:* bedrock

#### Properties and qualities

*Slope:* 25 to 65 percent  
*Depth to restrictive feature:* 20 to 33 inches to paralithic bedrock  
*Drainage class:* Well drained  
*Runoff class:* Very high  
*Capacity of the most limiting layer to transmit water (Ksat):* Low to moderately high  
(0.00 to 0.21 in/hr)  
*Depth to water table:* More than 80 inches  
*Frequency of flooding:* None  
*Frequency of ponding:* None  
*Calcium carbonate, maximum content:* 15 percent  
*Gypsum, maximum content:* 1 percent  
*Maximum salinity:* Nonsaline to very slightly saline (0.0 to 2.0 mmhos/cm)  
*Available water capacity:* Low (about 4.7 inches)

#### Interpretive groups

*Land capability classification (irrigated):* 7e  
*Land capability classification (nonirrigated):* 7e  
*Hydrologic Soil Group:* D  
*Ecological site:* R048BY296CO

## Custom Soil Resource Report

*Hydric soil rating:* No

### Minor Components

#### Routt

*Percent of map unit:* 5 percent  
*Landform:* Hills  
*Landform position (two-dimensional):* Backslope  
*Landform position (three-dimensional):* Side slope  
*Down-slope shape:* Linear  
*Across-slope shape:* Linear  
*Ecological site:* F048AY449CO  
*Hydric soil rating:* No

## C10—Impass silty clay loam, 3 to 12 percent slopes

### Map Unit Setting

*National map unit symbol:* k0ky  
*Elevation:* 6,560 to 7,870 feet  
*Mean annual precipitation:* 20 to 24 inches  
*Mean annual air temperature:* 38 to 41 degrees F  
*Frost-free period:* 30 to 70 days  
*Farmland classification:* Not prime farmland

### Map Unit Composition

*Impass and similar soils:* 80 percent  
*Minor components:* 20 percent  
*Estimates are based on observations, descriptions, and transects of the mapunit.*

### Description of Impass

#### Setting

*Landform:* Hills  
*Landform position (two-dimensional):* Backslope  
*Landform position (three-dimensional):* Side slope  
*Down-slope shape:* Linear  
*Across-slope shape:* Linear  
*Parent material:* Slope alluvium derived from sandstone and shale

#### Typical profile

*A - 0 to 4 inches:* silty clay loam  
*Bss - 4 to 18 inches:* silty clay  
*Bkss - 18 to 25 inches:* silty clay  
*Bk1 - 25 to 45 inches:* silty clay  
*Bk2 - 45 to 60 inches:* silty clay

#### Properties and qualities

*Slope:* 3 to 12 percent  
*Depth to restrictive feature:* More than 80 inches  
*Drainage class:* Well drained  
*Runoff class:* Medium

## Custom Soil Resource Report

*Capacity of the most limiting layer to transmit water (Ksat):* Moderately low to moderately high (0.07 to 0.21 in/hr)

*Depth to water table:* More than 80 inches

*Frequency of flooding:* None

*Frequency of ponding:* None

*Calcium carbonate, maximum content:* 15 percent

*Gypsum, maximum content:* 2 percent

*Maximum salinity:* Nonsaline to very slightly saline (0.0 to 2.0 mmhos/cm)

*Available water capacity:* High (about 10.2 inches)

### Interpretive groups

*Land capability classification (irrigated):* 6c

*Land capability classification (nonirrigated):* 6c

*Hydrologic Soil Group:* C

*Ecological site:* R048BY296CO

*Hydric soil rating:* No

### Minor Components

#### Gourley

*Percent of map unit:* 10 percent

*Landform:* Hills

*Landform position (two-dimensional):* Footslope

*Landform position (three-dimensional):* Side slope

*Down-slope shape:* Concave

*Across-slope shape:* Concave

*Ecological site:* R048AY247CO

*Hydric soil rating:* No

#### Routtskin

*Percent of map unit:* 5 percent

*Landform:* Hills

*Landform position (two-dimensional):* Backslope

*Landform position (three-dimensional):* Side slope

*Down-slope shape:* Linear

*Across-slope shape:* Linear

*Ecological site:* R048AY247CO

*Hydric soil rating:* No

#### Eckmanpark

*Percent of map unit:* 5 percent

*Landform:* Hills

*Landform position (two-dimensional):* Footslope

*Landform position (three-dimensional):* Side slope

*Down-slope shape:* Linear

*Across-slope shape:* Concave

*Ecological site:* R048BY296CO

*Hydric soil rating:* No

## Custom Soil Resource Report

Group C. Soils having a slow infiltration rate when thoroughly wet. These consist chiefly of soils having a layer that impedes the downward movement of water or soils of moderately fine texture or fine texture. These soils have a slow rate of water transmission.

Group D. Soils having a very slow infiltration rate (high runoff potential) when thoroughly wet. These consist chiefly of clays that have a high shrink-swell potential, soils that have a high water table, soils that have a claypan or clay layer at or near the surface, and soils that are shallow over nearly impervious material. These soils have a very slow rate of water transmission.

If a soil is assigned to a dual hydrologic group (A/D, B/D, or C/D), the first letter is for drained areas and the second is for undrained areas. Only the soils that in their natural condition are in group D are assigned to dual classes.

# Custom Soil Resource Report Map—Hydrologic Soil Group

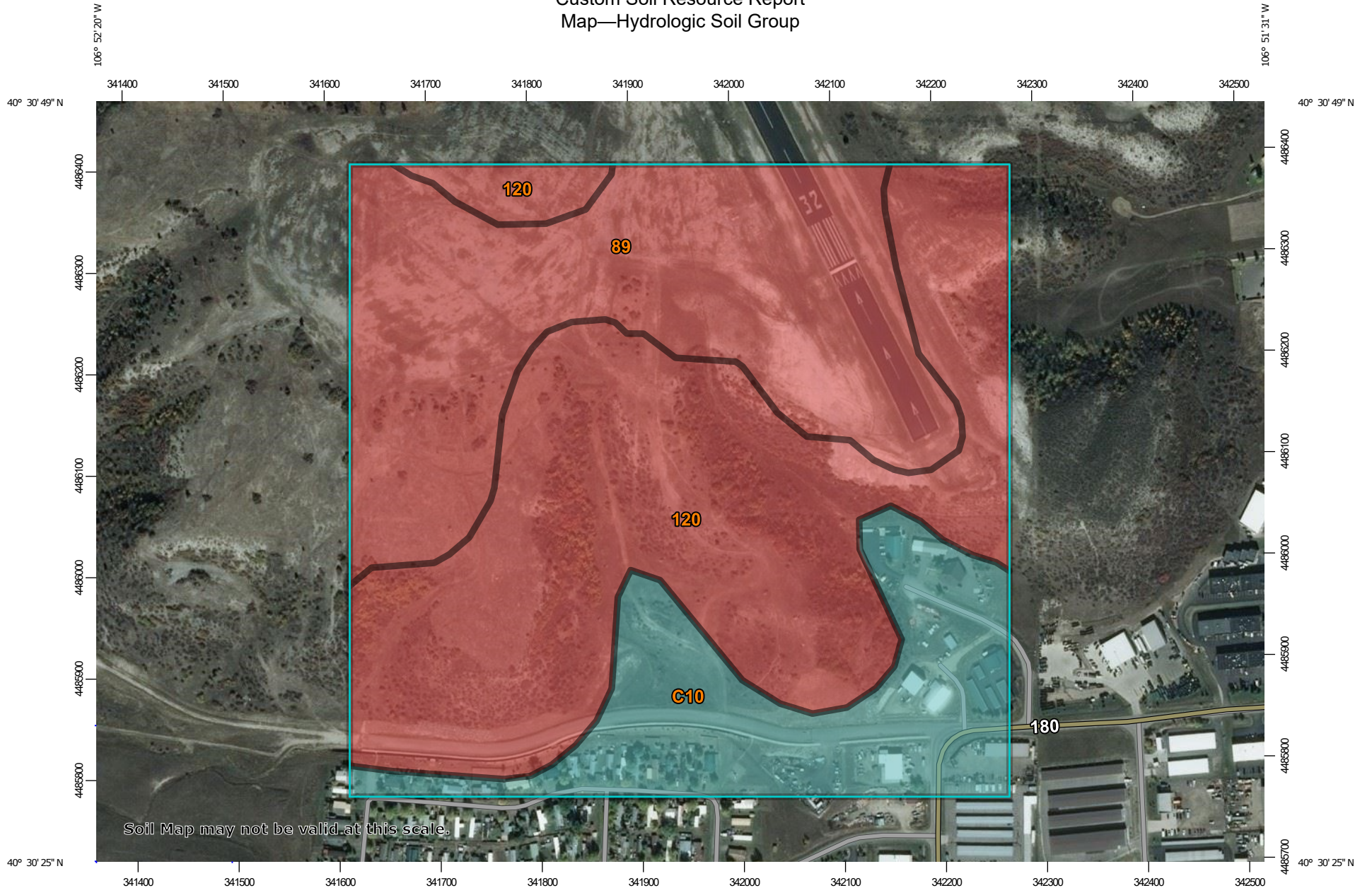

Map Scale: 1:5,280 if printed on A landscape (11" x 8.5") sheet.

0 50 100 200 300 Meters

0 250 500 1000 1500 Feet

Map projection: Web Mercator Corner coordinates: WGS84 Edge tics: UTM Zone 13N WGS84



### MAP LEGEND

**Area of Interest (AOI)**









 Area of Interest (AOI)

**Soils**

**Soil Rating Polygons**





-  A
-  A/D
-  B
-  B/D
-  C
-  C/D
-  D
-  Not rated or not available

**Soil Rating Lines**

-  A
-  A/D
-  B
-  B/D
-  C
-  C/D
-  D
-  Not rated or not available

**Soil Rating Points**





-  A
-  A/D
-  B
-  B/D

-  C
-  C/D
-  D
-  Not rated or not available

**Water Features**

 Streams and Canals

**Transportation**

-  Rails
-  Interstate Highways
-  US Routes
-  Major Roads
-  Local Roads

**Background**

 Aerial Photography

### MAP INFORMATION

The soil surveys that comprise your AOI were mapped at 1:24,000.

Warning: Soil Map may not be valid at this scale.

Enlargement of maps beyond the scale of mapping can cause misunderstanding of the detail of mapping and accuracy of soil line placement. The maps do not show the small areas of contrasting soils that could have been shown at a more detailed scale.

Please rely on the bar scale on each map sheet for map measurements.

Source of Map: Natural Resources Conservation Service  
 Web Soil Survey URL:  
 Coordinate System: Web Mercator (EPSG:3857)

Maps from the Web Soil Survey are based on the Web Mercator projection, which preserves direction and shape but distorts distance and area. A projection that preserves area, such as the Albers equal-area conic projection, should be used if more accurate calculations of distance or area are required.

This product is generated from the USDA-NRCS certified data as of the version date(s) listed below.

Soil Survey Area: Routt Area, Colorado, Parts of Rio Blanco and Routt Counties  
 Survey Area Data: Version 10, Jun 5, 2020

Soil map units are labeled (as space allows) for map scales 1:50,000 or larger.

Date(s) aerial images were photographed: May 8, 2012—Oct 5, 2017

The orthophoto or other base map on which the soil lines were compiled and digitized probably differs from the background

**Table—Hydrologic Soil Group**

Map unit symbol	Map unit name	Rating	Acres in AOI	Percent of AOI
89	Eckmanpark clay, 6 to 25 percent slopes	D	34.0	33.7%
120	Eckmanpark clay loam, 25 to 65 percent slopes	D	47.9	47.4%
C10	Impass silty clay loam, 3 to 12 percent slopes	C	19.1	18.9%
<b>Totals for Area of Interest</b>			<b>101.0</b>	<b>100.0%</b>

**Rating Options—Hydrologic Soil Group**

*Aggregation Method:* Dominant Condition

*Component Percent Cutoff:* None Specified

*Tie-break Rule:* Higher

C. Basin Runoff Calculations

**RATIONAL METHOD RUNOFF ANALYSIS**

Job # 1992-001 Date: April 13, 2021  
 Job Name Copper Ridge Revised:  
 Designed by: JLW

**Existing Basin 1 (EB1)**

BASIN CHARACTERISTICS				TIME OF CONCENTRATION					RESULTS						
	Area, ac	% imp	Soil Type	Overland Flow - Surface Type 1		Overland Flow - Surface Type 2		Channel Flow		Tc, min	Event	C	i, in/hr	A, acres	Q, cfs
Landscape	9.96	2%	C	Surface Imperviousness	0.02	Surface Imperviousness	0.02	Land Surface	Short Pature and Lawns	Minimum	1.25 YR	0.06	0.9	9.96	0.49
Asphalt Parking & Walkways	0.00	100%		Length, ft	300	Length, ft	300	Length, ft	50	Tc, min	2-YR	0.06	1.3	9.96	0.71
Roof	0.00	90%	P2	Slope, percent	25.0000	Slope, percent	15.0000	Slope, ft/ft	10.0000	5.0	5-YR	0.16	1.9	9.96	3.12
Gravel	0.00	40%		Runoff Coefficient	0.162	Runoff Coefficient	0.162	Conveyance Coefficient	7	Final	10-YR	0.26	2.4	9.96	6.36
Other	0.00	0%	1.4					Velocity, ft/s	22.1	Tc, min	25-YR	0.38	3.1	9.96	11.89
				Ti, min= 10.0		Ti, min= 11.9		Tt, min= 0.0		21.9	100-YR	0.51	4.2	9.96	21.25

**Existing Basin 2 (EB2)**

BASIN CHARACTERISTICS				TIME OF CONCENTRATION					RESULTS						
	Area, ac	% imp	Soil Type	Overland Flow - Surface Type 1		Overland Flow - Surface Type 2		Channel Flow		Tc, min	Event	C	i, in/hr	A, acres	Q, cfs
Landscape	5.06	2%	C	Surface Imperviousness	0.02	Surface Imperviousness	0.02	Land Surface	Paved Areas and Shallow Swales	Minimum	1.25 YR	0.06	1.4	5.06	0.40
Asphalt Parking & Walkways	0.00	100%		Length, ft	250	Length, ft	0	Length, ft	0	Tc, min	2-YR	0.06	2.1	5.06	0.57
Roof	0.00	90%	P2	Slope, percent	30.0000	Slope, percent	1.0000	Slope, ft/ft	1.0000	5.0	5-YR	0.16	3.1	5.06	2.53
Gravel	0.00	0%		Runoff Coefficient	0.162	Runoff Coefficient	0.162	Conveyance Coefficient	20	Final	10-YR	0.26	3.9	5.06	5.15
Other	0.00	0%	1.4					Velocity, ft/s	20.0	Tc, min	25-YR	0.38	5.0	5.06	9.64
				Ti, min= 8.6		Ti, min= 0.0		Tt, min= 0.0		8.6	100-YR	0.51	6.7	5.06	17.22

**Existing Basin 3 (EB3)**

BASIN CHARACTERISTICS				TIME OF CONCENTRATION					RESULTS						
	Area, ac	% imp	Soil Type	Overland Flow - Surface Type 1		Overland Flow - Surface Type 2		Channel Flow		Tc, min	Event	C	i, in/hr	A, acres	Q, cfs
Landscape	12.50	2%	C	Surface Imperviousness	0.02	Surface Imperviousness	0.02	Land Surface	Short Pature and Lawns	Minimum	1.25 YR	0.06	0.7	12.50	0.45
Asphalt Parking & Walkways	0.00	100%		Length, ft	300	Length, ft	300	Length, ft	500	Tc, min	2-YR	0.06	0.9	12.50	0.65
Roof	0.00	90%	P2	Slope, percent	5.0000	Slope, percent	10.0000	Slope, ft/ft	0.2000	5.0	5-YR	0.16	1.4	12.50	2.86
Gravel	0.00	0%		Runoff Coefficient	0.162	Runoff Coefficient	0.162	Conveyance Coefficient	7	Final	10-YR	0.26	1.8	12.50	5.86
Other	0.00	0%	1.4					Velocity, ft/s	3.1	Tc, min	25-YR	0.38	2.3	12.50	10.93
				Ti, min= 17.1		Ti, min= 13.6		Tt, min= 2.7		33.3	100-YR	0.51	3.1	12.50	19.54

**Existing Basin 4 (EB4)**

BASIN CHARACTERISTICS				TIME OF CONCENTRATION					RESULTS						
	Area, ac	% imp	Soil Type	Overland Flow - Surface Type 1		Overland Flow - Surface Type 2		Channel Flow		Tc, min	Event	C	i, in/hr	A, acres	Q, cfs
Landscape	0.93	2%	C	Surface Imperviousness	0.02	Surface Imperviousness	0	Land Surface	Grassed Waterways	Minimum	1.25 YR	0.06	1.4	0.93	0.07
Asphalt Parking & Walkways	0.00	100%		Length, ft	150	Length, ft	0	Length, ft	0	Tc, min	2-YR	0.06	2.0	0.93	0.10
Roof	0.00	90%	P2	Slope, percent	10.0000	Slope, percent	1.0000	Slope, ft/ft	1.0000	5.0	5-YR	0.16	2.9	0.93	0.44
Gravel	0.00	0%		Runoff Coefficient	0.162	Runoff Coefficient	0.15	Conveyance Coefficient	15	Final	10-YR	0.26	3.7	0.93	0.91
Other	0.00	0%	1.4					Velocity, ft/s	15.0	Tc, min	25-YR	0.38	4.8	0.93	1.69
				Ti, min= 9.6		Ti, min= 0.0		Tt, min= 0.0		9.6	100-YR	0.51	6.4	0.93	3.02

**Existing Basin 5 (EB5)**

BASIN CHARACTERISTICS				TIME OF CONCENTRATION					RESULTS						
	Area, ac	% imp	Soil Type	Overland Flow - Surface Type 1		Overland Flow - Surface Type 2		Channel Flow		Tc, min	Event	C	i, in/hr	A, acres	Q, cfs
Landscape	1.59	2%	C	Surface Imperviousness	0.02	Surface Imperviousness	0	Land Surface	Grassed Waterways	Minimum	1.25 YR	0.14	1.2	1.82	0.31
Asphalt Parking & Walkways	0.23	100%		Length, ft	300	Length, ft	0	Length, ft	650	Tc, min	2-YR	0.14	1.8	1.82	0.44

**RATIONAL METHOD RUNOFF ANALYSIS**

Job # 1992-001 Date: April 13, 2021  
 Job Name Copper Ridge Revised:  
 Designed by: JLW

Roof	0.00	90%	P2	Slope, percent	32.0000	Slope, percent	1.0000	Slope, ft/ft	0.0500	5.0	5-YR	0.23	2.6	1.82	1.11
Gravel	0.00	0%	1.4	Runoff Coefficient	0.162	Runoff Coefficient	0.15	Conveyance Coefficient	15	Final	10-YR	0.32	3.3	1.82	1.94
Other	0.00	0%		Velocity, ft/s	3.4	Tc, min	25-YR	0.43	4.3	1.82	3.33				
1.82 14%			Ti, min= 9.2		Ti, min= 0.0		Tt, min= 3.2		12.4	100-YR	0.54	5.7	1.82	5.63	

**Dev Basin 1 (DB1)**

BASIN CHARACTERISTICS				TIME OF CONCENTRATION						RESULTS					
	Area, ac	% imp	Soil Type	Overland Flow - Surface Type 1		Overland Flow - Surface Type 2		Channel Flow		Tc, min	Event	C	i, in/hr	A, acres	Q, cfs
Landscape	4.68	2%	C	Surface Imperviousness	0.25	Surface Imperviousness	0.75	Land Surface	Paved Areas and Shallow Swales	Minimum	1.25 YR	0.30	1.1	8.31	2.71
Asphalt Parking & Walkways	2.29	100%		Length, ft	250	Length, ft	200	Length, ft	250	Tc, min	2-YR	0.30	1.6	8.31	3.89
Roof	1.34	90%	P2	Slope, percent	33.0000	Slope, percent	5.0000	Slope, ft/ft	0.0700	5.0	5-YR	0.37	2.3	8.31	7.07
Gravel	0.00	0%	1.4	Runoff Coefficient	0.28	Runoff Coefficient	0.58	Conveyance Coefficient	20	Final	10-YR	0.43	2.9	8.31	10.59
Other	0.00	0%		Velocity, ft/s	5.3	Tc, min	25-YR	0.51	3.8	8.31	16.04				
8.31 44%			Ti, min= 7.3		Ti, min= 7.7		Tt, min= 0.8		15.8	100-YR	0.59	5.1	8.31	24.89	

**Dev Basin 2 (DB2)**

BASIN CHARACTERISTICS				TIME OF CONCENTRATION						RESULTS					
	Area, ac	% imp	Soil Type	Overland Flow - Surface Type 1		Overland Flow - Surface Type 2		Channel Flow		Tc, min	Event	C	i, in/hr	A, acres	Q, cfs
Landscape	4.30	2%	C	Surface Imperviousness	0.02	Surface Imperviousness	0	Land Surface	Grassed Waterways	Minimum	1.25 YR	0.06	1.5	4.30	0.35
Asphalt Parking & Walkways	0.00	100%		Length, ft	250	Length, ft	0	Length, ft	0	Tc, min	2-YR	0.06	2.1	4.30	0.51
Roof	0.00	90%	P2	Slope, percent	40.0000	Slope, percent	1.0000	Slope, ft/ft	1.0000	5.0	5-YR	0.16	3.2	4.30	2.23
Gravel	0.00	0%	1.4	Runoff Coefficient	0.162	Runoff Coefficient	0.15	Conveyance Coefficient	15	Final	10-YR	0.26	4.0	4.30	4.55
Other	0.00	0%		Velocity, ft/s	15.0	Tc, min	25-YR	0.38	5.2	4.30	8.50				
4.30 2%			Ti, min= 7.8		Ti, min= 0.0		Tt, min= 0.0		7.8	100-YR	0.51	7.0	4.30	15.19	

**Dev Basin 3 (DB3)**

BASIN CHARACTERISTICS				TIME OF CONCENTRATION						RESULTS					
	Area, ac	% imp	Soil Type	Overland Flow - Surface Type 1		Overland Flow - Surface Type 2		Channel Flow		Tc, min	Event	C	i, in/hr	A, acres	Q, cfs
Landscape	1.41	2%	C	Surface Imperviousness	0.02	Surface Imperviousness	0	Land Surface	Grassed Waterways	Minimum	1.25 YR	0.19	1.2	1.82	0.43
Asphalt Parking & Walkways	0.41	100%		Length, ft	300	Length, ft	0	Length, ft	650	Tc, min	2-YR	0.19	1.8	1.82	0.61
Roof	0.00	90%	P2	Slope, percent	32.0000	Slope, percent	1.0000	Slope, ft/ft	0.0500	5.0	5-YR	0.28	2.6	1.82	1.32
Gravel	0.00	0%	1.4	Runoff Coefficient	0.162	Runoff Coefficient	0.15	Conveyance Coefficient	15	Final	10-YR	0.36	3.3	1.82	2.17
Other	0.00	0%		Velocity, ft/s	3.4	Tc, min	25-YR	0.46	4.3	1.82	3.54				
1.82 24%			Ti, min= 9.2		Ti, min= 0.0		Tt, min= 3.2		12.4	100-YR	0.56	5.7	1.82	5.81	

**Sub Basin 1 (SB1)**

BASIN CHARACTERISTICS				TIME OF CONCENTRATION						RESULTS					
	Area, ac	% imp	Soil Type	Overland Flow - Surface Type 1		Overland Flow - Surface Type 2		Channel Flow		Tc, min	Event	C	i, in/hr	A, acres	Q, cfs
Landscape	0.93	2%	C	Surface Imperviousness	0.05	Surface Imperviousness	0	Land Surface	Grassed Waterways	Minimum	1.25 YR	0.08	1.4	0.96	0.11
Asphalt Parking & Walkways	0.03	100%		Length, ft	260	Length, ft	0	Length, ft	0	Tc, min	2-YR	0.08	2.1	0.96	0.15
Roof	0.00	90%	P2	Slope, percent	33.0000	Slope, percent	1.0000	Slope, ft/ft	1.0000	5.0	5-YR	0.18	3.1	0.96	0.54
Gravel	0.00	0%	1.4	Runoff Coefficient	0.18	Runoff Coefficient	0.15	Conveyance Coefficient	15	Final	10-YR	0.28	3.9	0.96	1.05
Other	0.00	0%		Velocity, ft/s	15.0	Tc, min	25-YR	0.39	5.1	0.96	1.92				
0.96 5%			Ti, min= 8.3		Ti, min= 0.0		Tt, min= 0.0		8.3	100-YR	0.52	6.8	0.96	3.37	

**RATIONAL METHOD RUNOFF ANALYSIS**

Job # 1992-001 Date: April 13, 2021  
 Job Name Copper Ridge Revised:  
 Designed by: JLW

**Sub Basin 2 (SB2)**

BASIN CHARACTERISTICS				TIME OF CONCENTRATION					RESULTS						
	Area, ac	% imp	Soil Type	Overland Flow - Surface Type 1		Overland Flow - Surface Type 2		Channel Flow		Tc, min	Event	C	i, in/hr	A, acres	Q, cfs
Landscape	0.12	2%	C	Surface Imperviousness	0.02	Surface Imperviousness	0	Land Surface	Grassed Waterways	Minimum	1.25 YR	0.06	1.7	0.12	0.01
Asphalt Parking & Walkways	0.00	100%		Length, ft	50	Length, ft	0	Length, ft	0	Tc, min	2-YR	0.06	2.5	0.12	0.02
Roof	0.00	90%	P2	Slope, percent	33.0000	Slope, percent	1.0000	Slope, ft/ft	1.0000	5.0	5-YR	0.16	3.7	0.12	0.07
Gravel	0.00	0%	1.4	Runoff Coefficient	0.162	Runoff Coefficient	0.15	Conveyance Coefficient	15	Final	10-YR	0.26	4.7	0.12	0.15
Other	0.00	0%		Velocity, ft/s		Velocity, ft/s	15.0			Tc, min	25-YR	0.38	6.1	0.12	0.28
				Ti, min= 3.7		Ti, min= 0.0		Tt, min= 0.0		5.0	100-YR	0.51	8.2	0.12	0.50

**Sub Basin 3 (SB3)**

BASIN CHARACTERISTICS				TIME OF CONCENTRATION					RESULTS						
	Area, ac	% imp	Soil Type	Overland Flow - Surface Type 1		Overland Flow - Surface Type 2		Channel Flow		Tc, min	Event	C	i, in/hr	A, acres	Q, cfs
Landscape	0.34	2%	C	Surface Imperviousness	0.02	Surface Imperviousness	0	Land Surface	Grassed Waterways	Minimum	1.25 YR	0.06	1.3	0.34	0.02
Asphalt Parking & Walkways	0.00	100%		Length, ft	100	Length, ft	0	Length, ft	0	Tc, min	2-YR	0.06	1.9	0.34	0.04
Roof	0.00	90%	P2	Slope, percent	4.0000	Slope, percent	1.0000	Slope, ft/ft	1.0000	5.0	5-YR	0.16	2.8	0.34	0.16
Gravel	0.00	0%	1.4	Runoff Coefficient	0.162	Runoff Coefficient	0.15	Conveyance Coefficient	15	Final	10-YR	0.26	3.6	0.34	0.32
Other	0.00	0%		Velocity, ft/s		Velocity, ft/s	15.0			Tc, min	25-YR	0.38	4.6	0.34	0.59
				Ti, min= 10.6		Ti, min= 0.0		Tt, min= 0.0		10.6	100-YR	0.51	6.1	0.34	1.06

**Sub Basin 4 (SB4)**

BASIN CHARACTERISTICS				TIME OF CONCENTRATION					RESULTS						
	Area, ac	% imp	Soil Type	Overland Flow - Surface Type 1		Overland Flow - Surface Type 2		Channel Flow		Tc, min	Event	C	i, in/hr	A, acres	Q, cfs
Landscape	0.12	2%	C	Surface Imperviousness	0.02	Surface Imperviousness	0	Land Surface	Grassed Waterways	Minimum	1.25 YR	0.06	1.2	0.12	0.01
Asphalt Parking & Walkways	0.00	100%		Length, ft	115	Length, ft	0	Length, ft	0	Tc, min	2-YR	0.06	1.7	0.12	0.01
Roof	0.00	90%	P2	Slope, percent	3.0000	Slope, percent	1.0000	Slope, ft/ft	1.0000	5.0	5-YR	0.16	2.6	0.12	0.05
Gravel	0.00	0%	1.4	Runoff Coefficient	0.162	Runoff Coefficient	0.15	Conveyance Coefficient	15	Final	10-YR	0.26	3.3	0.12	0.10
Other	0.00	0%		Velocity, ft/s		Velocity, ft/s	15.0			Tc, min	25-YR	0.38	4.3	0.12	0.19
				Ti, min= 12.6		Ti, min= 0.0		Tt, min= 0.0		12.6	100-YR	0.51	5.7	0.12	0.35

**Sub Basin 5 (SB5)**

BASIN CHARACTERISTICS				TIME OF CONCENTRATION					RESULTS						
	Area, ac	% imp	Soil Type	Overland Flow - Surface Type 1		Overland Flow - Surface Type 2		Channel Flow		Tc, min	Event	C	i, in/hr	A, acres	Q, cfs
Landscape	0.87	2%	C	Surface Imperviousness	0.02	Surface Imperviousness	0.3	Land Surface	Grassed Waterways	Minimum	1.25 YR	0.06	1.1	0.87	0.05
Asphalt Parking & Walkways	0.00	100%		Length, ft	150	Length, ft	120	Length, ft	0	Tc, min	2-YR	0.06	1.6	0.87	0.08
Roof	0.00	90%	P2	Slope, percent	50.0000	Slope, percent	5.0000	Slope, ft/ft	1.0000	5.0	5-YR	0.16	2.4	0.87	0.34
Gravel	0.00	0%	1.4	Runoff Coefficient	0.162	Runoff Coefficient	0.3	Conveyance Coefficient	15	Final	10-YR	0.26	3.0	0.87	0.69
Other	0.00	0%		Velocity, ft/s		Velocity, ft/s	15.0			Tc, min	25-YR	0.38	3.9	0.87	1.30
				Ti, min= 5.6		Ti, min= 9.2		Tt, min= 0.0		14.8	100-YR	0.51	5.2	0.87	2.32

**Sub Basin 6 (SB6)**

BASIN CHARACTERISTICS				TIME OF CONCENTRATION					RESULTS						
	Area, ac	% imp	Soil Type	Overland Flow - Surface Type 1		Overland Flow - Surface Type 2		Channel Flow		Tc, min	Event	C	i, in/hr	A, acres	Q, cfs
Landscape	0.04	2%	C	Surface Imperviousness	1	Surface Imperviousness	0.02	Land Surface	Short Pature and Lawns	Minimum	1.25 YR	0.34	1.7	0.08	0.05
Asphalt Parking & Walkways	0.04	100%		Length, ft	20	Length, ft	10	Length, ft	120	Tc, min	2-YR	0.34	2.5	0.08	0.07
Roof	0.00	90%	P2	Slope, percent	8.0000	Slope, percent	10.0000	Slope, ft/ft	0.0800	5.0	5-YR	0.40	3.7	0.08	0.12

**RATIONAL METHOD RUNOFF ANALYSIS**

Job # 1992-001 Date: April 13, 2021  
 Job Name Copper Ridge Revised:  
 Designed by: JLW

Gravel	0.00	0%	1.4	Runoff Coefficient	0.9	Runoff Coefficient	0.162	Conveyance Coefficient	7	Final	10-YR	0.46	4.7	0.08	0.18
Other	0.00	0%		Velocity, ft/s				2.0	Tc, min	25-YR	0.53	6.1	0.08	0.26	
0.08 51%				Ti, min=	0.8	Ti, min=	2.5	Tt, min=	1.0	<b>5.0</b>	<b>100-YR</b>	<b>0.61</b>	<b>8.2</b>	<b>0.08</b>	<b>0.39</b>

**Sub Basin 7 (SB7)**

BASIN CHARACTERISTICS				TIME OF CONCENTRATION					RESULTS						
	Area, ac	% imp	Soil Type	Overland Flow - Surface Type 1		Overland Flow - Surface Type 2		Channel Flow		Tc, min	Event	C	i, in/hr	A, acres	Q, cfs
Landscape	0.26	2%	C	Surface Imperviousness	0.02	Surface Imperviousness	0.02	Land Surface	Short Pature and Lawns	Minimum	1.25 YR	0.06	1.7	0.26	0.02
Asphalt Parking & Walkways	0.00	100%		Length, ft	50	Length, ft	0	Length, ft	0	Tc, min	2-YR	0.06	2.5	0.26	0.04
Roof	0.00	90%	P2	Slope, percent	50.0000	Slope, percent	1.0000	Slope, ft/ft	1.0000	5.0	5-YR	0.16	3.7	0.26	0.16
Gravel	0.00	0%	1.4	Runoff Coefficient	0.162	Runoff Coefficient	0.162	Conveyance Coefficient	7	Final	10-YR	0.26	4.7	0.26	0.32
Other	0.00	0%		Velocity, ft/s				7.0	Tc, min	25-YR	0.38	6.1	0.26	0.60	
0.26 2%				Ti, min=	3.2	Ti, min=	0.0	Tt, min=	0.0	<b>5.0</b>	<b>100-YR</b>	<b>0.51</b>	<b>8.2</b>	<b>0.26</b>	<b>1.08</b>

**Sub Basin 8 (SB8)**

BASIN CHARACTERISTICS				TIME OF CONCENTRATION					RESULTS						
	Area, ac	% imp	Soil Type	Overland Flow - Surface Type 1		Overland Flow - Surface Type 2		Channel Flow		Tc, min	Event	C	i, in/hr	A, acres	Q, cfs
Landscape	0.03	2%	C	Surface Imperviousness	0.55	Surface Imperviousness	0.02	Land Surface	Short Pature and Lawns	Minimum	1.25 YR	0.39	1.7	0.07	0.05
Asphalt Parking & Walkways	0.04	100%		Length, ft	60	Length, ft	0	Length, ft	0	Tc, min	2-YR	0.39	2.5	0.07	0.07
Roof	0.00	90%	P2	Slope, percent	10.0000	Slope, percent	1.0000	Slope, ft/ft	1.0000	5.0	5-YR	0.44	3.7	0.07	0.12
Gravel	0.00	0%	1.4	Runoff Coefficient	0.43	Runoff Coefficient	0.162	Conveyance Coefficient	7	Final	10-YR	0.50	4.7	0.07	0.16
Other	0.00	0%		Velocity, ft/s				7.0	Tc, min	25-YR	0.56	6.1	0.07	0.24	
0.07 58%				Ti, min=	4.3	Ti, min=	0.0	Tt, min=	0.0	<b>5.0</b>	<b>100-YR</b>	<b>0.63</b>	<b>8.2</b>	<b>0.07</b>	<b>0.36</b>

**Sub Basin 9 (SB9)**

BASIN CHARACTERISTICS				TIME OF CONCENTRATION					RESULTS						
	Area, ac	% imp	Soil Type	Overland Flow - Surface Type 1		Overland Flow - Surface Type 2		Channel Flow		Tc, min	Event	C	i, in/hr	A, acres	Q, cfs
Landscape	0.02	2%	C	Surface Imperviousness	0.9	Surface Imperviousness	0.02	Land Surface	Short Pature and Lawns	Minimum	1.25 YR	0.74	1.6	0.33	0.39
Asphalt Parking & Walkways	0.20	100%		Length, ft	160	Length, ft	0	Length, ft	0	Tc, min	2-YR	0.74	2.3	0.33	0.56
Roof	0.11	90%	P2	Slope, percent	2.0000	Slope, percent	1.0000	Slope, ft/ft	1.0000	5.0	5-YR	0.76	3.4	0.33	0.86
Gravel	0.00	0%	1.4	Runoff Coefficient	0.75	Runoff Coefficient	0.162	Conveyance Coefficient	7	Final	10-YR	0.78	4.4	0.33	1.13
Other	0.00	0%		Velocity, ft/s				7.0	Tc, min	25-YR	0.81	5.6	0.33	1.51	
0.33 91%				Ti, min=	6.3	Ti, min=	0.0	Tt, min=	0.0	<b>6.3</b>	<b>100-YR</b>	<b>0.84</b>	<b>7.5</b>	<b>0.33</b>	<b>2.09</b>

**Sub Basin 10 (SB10)**

BASIN CHARACTERISTICS				TIME OF CONCENTRATION					RESULTS						
	Area, ac	% imp	Soil Type	Overland Flow - Surface Type 1		Overland Flow - Surface Type 2		Channel Flow		Tc, min	Event	C	i, in/hr	A, acres	Q, cfs
Landscape	0.40	2%	C	Surface Imperviousness	0.02	Surface Imperviousness	0.02	Land Surface	Short Pature and Lawns	Minimum	1.25 YR	0.06	1.6	0.40	0.04
Asphalt Parking & Walkways	0.00	100%		Length, ft	160	Length, ft	0	Length, ft	0	Tc, min	2-YR	0.06	2.3	0.40	0.05
Roof	0.00	90%	P2	Slope, percent	42.0000	Slope, percent	1.0000	Slope, ft/ft	1.0000	5.0	5-YR	0.16	3.5	0.40	0.23
Gravel	0.00	0%	1.4	Runoff Coefficient	0.162	Runoff Coefficient	0.162	Conveyance Coefficient	7	Final	10-YR	0.26	4.4	0.40	0.46
Other	0.00	0%		Velocity, ft/s				7.0	Tc, min	25-YR	0.38	5.7	0.40	0.86	
0.40 2%				Ti, min=	6.1	Ti, min=	0.0	Tt, min=	0.0	<b>6.1</b>	<b>100-YR</b>	<b>0.51</b>	<b>7.6</b>	<b>0.40</b>	<b>1.54</b>

**Sub Basin 11 (SB11)**

**RATIONAL METHOD RUNOFF ANALYSIS**

Job # 1992-001 Date: April 13, 2021  
 Job Name Copper Ridge Revised:  
 Designed by: JLW

BASIN CHARACTERISTICS				TIME OF CONCENTRATION						RESULTS					
	Area, ac	% imp	Soil Type	Overland Flow - Surface Type 1		Overland Flow - Surface Type 2		Channel Flow		Tc, min	Event	C	i, in/hr	A, acres	Q, cfs
Landscape	0.08	2%	C	Surface Imperviousness	0.8	Surface Imperviousness	0.02	Land Surface	Short Pature and Lawns	Minimum	1.25 YR	0.59	1.5	0.56	0.50
Asphalt Parking & Walkways	0.14	100%		Length, ft	230	Length, ft	0	Length, ft	0	Tc, min	2-YR	0.59	2.2	0.56	0.72
Roof	0.34	90%	P2	Slope, percent	5.0000	Slope, percent	1.0000	Slope, ft/ft	1.0000	5.0	5-YR	0.62	3.2	0.56	1.13
Gravel	0.00	0%	1.4	Runoff Coefficient	0.63	Runoff Coefficient	0.162	Conveyance Coefficient	7	Final	10-YR	0.66	4.1	0.56	1.52
Other	0.00	0%		Velocity, ft/s		7.0			Tc, min	25-YR	0.70	5.3	0.56	2.08	
				Ti, min=	7.5	Ti, min=	0.0	Tt, min=	0.0	<b>7.5</b>	<b>100-YR</b>	<b>0.74</b>	<b>7.1</b>	<b>0.56</b>	<b>2.94</b>

**Sub Basin 12 (SB12)**

BASIN CHARACTERISTICS				TIME OF CONCENTRATION						RESULTS					
	Area, ac	% imp	Soil Type	Overland Flow - Surface Type 1		Overland Flow - Surface Type 2		Channel Flow		Tc, min	Event	C	i, in/hr	A, acres	Q, cfs
Landscape	0.08	2%	C	Surface Imperviousness	0.55	Surface Imperviousness	0.02	Land Surface	Short Pature and Lawns	Minimum	1.25 YR	0.37	1.6	0.18	0.11
Asphalt Parking & Walkways	0.07	100%		Length, ft	120	Length, ft	0	Length, ft	0	Tc, min	2-YR	0.37	2.3	0.18	0.15
Roof	0.03	90%	P2	Slope, percent	10.0000	Slope, percent	1.0000	Slope, ft/ft	1.0000	5.0	5-YR	0.42	3.5	0.18	0.27
Gravel	0.00	0%	1.4	Runoff Coefficient	0.43	Runoff Coefficient	0.162	Conveyance Coefficient	7	Final	10-YR	0.48	4.4	0.18	0.38
Other	0.00	0%		Velocity, ft/s		7.0			Tc, min	25-YR	0.55	5.7	0.18	0.56	
				Ti, min=	6.1	Ti, min=	0.0	Tt, min=	0.0	<b>6.1</b>	<b>100-YR</b>	<b>0.62</b>	<b>7.6</b>	<b>0.18</b>	<b>0.84</b>

**Sub Basin 13 (SB13)**

BASIN CHARACTERISTICS				TIME OF CONCENTRATION						RESULTS					
	Area, ac	% imp	Soil Type	Overland Flow - Surface Type 1		Overland Flow - Surface Type 2		Channel Flow		Tc, min	Event	C	i, in/hr	A, acres	Q, cfs
Landscape	0.13	2%	C	Surface Imperviousness	0.1	Surface Imperviousness	0.02	Land Surface	Paved Areas and Shallow Swales	Minimum	1.25 YR	0.34	1.6	0.26	0.15
Asphalt Parking & Walkways	0.13	100%		Length, ft	50	Length, ft	0	Length, ft	230	Tc, min	2-YR	0.34	2.3	0.26	0.21
Roof	0.00	90%	P2	Slope, percent	10.0000	Slope, percent	1.0000	Slope, ft/ft	0.0700	5.0	5-YR	0.40	3.5	0.26	0.37
Gravel	0.00	0%	1.4	Runoff Coefficient	0.21	Runoff Coefficient	0.162	Conveyance Coefficient	20	Final	10-YR	0.46	4.5	0.26	0.54
Other	0.00	0%		Velocity, ft/s		5.3			Tc, min	25-YR	0.53	5.7	0.26	0.79	
				Ti, min=	5.3	Ti, min=	0.0	Tt, min=	0.7	<b>6.0</b>	<b>100-YR</b>	<b>0.61</b>	<b>7.7</b>	<b>0.26</b>	<b>1.21</b>

**Sub Basin 14 (SB14)**

BASIN CHARACTERISTICS				TIME OF CONCENTRATION						RESULTS					
	Area, ac	% imp	Soil Type	Overland Flow - Surface Type 1		Overland Flow - Surface Type 2		Channel Flow		Tc, min	Event	C	i, in/hr	A, acres	Q, cfs
Landscape	0.04	2%	C	Surface Imperviousness	0.02	Surface Imperviousness	0.02	Land Surface	Short Pature and Lawns	Minimum	1.25 YR	0.06	1.6	0.04	0.00
Asphalt Parking & Walkways	0.00	100%		Length, ft	60	Length, ft	0	Length, ft	0	Tc, min	2-YR	0.06	2.3	0.04	0.01
Roof	0.00	90%	P2	Slope, percent	10.0000	Slope, percent	1.0000	Slope, ft/ft	1.0000	5.0	5-YR	0.16	3.5	0.04	0.02
Gravel	0.00	0%	1.4	Runoff Coefficient	0.162	Runoff Coefficient	0.162	Conveyance Coefficient	7	Final	10-YR	0.26	4.4	0.04	0.05
Other	0.00	0%		Velocity, ft/s		7.0			Tc, min	25-YR	0.38	5.7	0.04	0.09	
				Ti, min=	6.1	Ti, min=	0.0	Tt, min=	0.0	<b>6.1</b>	<b>100-YR</b>	<b>0.51</b>	<b>7.6</b>	<b>0.04</b>	<b>0.15</b>

**Sub Basin 15 (SB15)**

BASIN CHARACTERISTICS				TIME OF CONCENTRATION						RESULTS					
	Area, ac	% imp	Soil Type	Overland Flow - Surface Type 1		Overland Flow - Surface Type 2		Channel Flow		Tc, min	Event	C	i, in/hr	A, acres	Q, cfs
Landscape	0.08	2%	C	Surface Imperviousness	0.55	Surface Imperviousness	0.02	Land Surface	Short Pature and Lawns	Minimum	1.25 YR	0.38	1.5	0.18	0.10
Asphalt Parking & Walkways	0.10	100%		Length, ft	160	Length, ft	0	Length, ft	0	Tc, min	2-YR	0.38	2.1	0.18	0.14
Roof	0.00	90%	P2	Slope, percent	7.0000	Slope, percent	1.0000	Slope, ft/ft	1.0000	5.0	5-YR	0.43	3.1	0.18	0.25
Gravel	0.00	0%	1.4	Runoff Coefficient	0.43	Runoff Coefficient	0.162	Conveyance Coefficient	7	Final	10-YR	0.49	4.0	0.18	0.35
Other	0.00	0%		Velocity, ft/s		7.0			Tc, min	25-YR	0.55	5.2	0.18	0.51	
				Ti, min=	8.0	Ti, min=	0.0	Tt, min=	0.0	<b>8.0</b>	<b>100-YR</b>	<b>0.62</b>	<b>6.9</b>	<b>0.18</b>	<b>0.77</b>

**Sub Basin 16 (SB16)**

**RATIONAL METHOD RUNOFF ANALYSIS**

Job # 1992-001 Date: April 13, 2021  
 Job Name Copper Ridge Revised:  
 Designed by: JLW

BASIN CHARACTERISTICS				TIME OF CONCENTRATION						RESULTS					
	Area, ac	% imp	Soil Type	Overland Flow - Surface Type 1		Overland Flow - Surface Type 2		Channel Flow		Tc, min	Event	C	i, in/hr	A, acres	Q, cfs
Landscape	0.34	2%	C	Surface Imperviousness	0.02	Surface Imperviousness	0.02	Land Surface	Short Pature and Lawns	Minimum	1.25 YR	0.06	1.7	0.34	0.03
Asphalt Parking & Walkways	0.00	100%		Length, ft	120	Length, ft	0	Length, ft	0	Tc, min	2-YR	0.06	2.4	0.34	0.04
Roof	0.00	90%	P2	Slope, percent	33.0000	Slope, percent	1.0000	Slope, ft/ft	1.0000	5.0	5-YR	0.16	3.5	0.34	0.20
Gravel	0.00	0%		1.4	Runoff Coefficient	0.162	Runoff Coefficient	0.162	Conveyance Coefficient	7	Final	10-YR	0.26	4.5	0.34
Other	0.00	0%						Velocity, ft/s	7.0	Tc, min	25-YR	0.38	5.8	0.34	0.75
				Ti, min=	5.8	Ti, min=	0.0	Tt, min=	0.0	5.8	100-YR	0.51	7.8	0.34	1.34

**Sub Basin 17 (SB17)**

BASIN CHARACTERISTICS				TIME OF CONCENTRATION						RESULTS					
	Area, ac	% imp	Soil Type	Overland Flow - Surface Type 1		Overland Flow - Surface Type 2		Channel Flow		Tc, min	Event	C	i, in/hr	A, acres	Q, cfs
Landscape	0.75	2%	C	Surface Imperviousness	0.2	Surface Imperviousness	0.02	Land Surface	Short Pature and Lawns	Minimum	1.25 YR	0.17	1.5	0.91	0.22
Asphalt Parking & Walkways	0.16	100%		Length, ft	300	Length, ft	0	Length, ft	50	Tc, min	2-YR	0.17	2.1	0.91	0.32
Roof	0.00	90%	P2	Slope, percent	33.0000	Slope, percent	1.0000	Slope, ft/ft	7.0000	5.0	5-YR	0.26	3.1	0.91	0.73
Gravel	0.00	0%		1.4	Runoff Coefficient	0.26	Runoff Coefficient	0.162	Conveyance Coefficient	7	Final	10-YR	0.34	4.0	0.91
Other	0.00	0%						Velocity, ft/s	18.5	Tc, min	25-YR	0.44	5.1	0.91	2.06
				Ti, min=	8.2	Ti, min=	0.0	Tt, min=	0.0	8.2	100-YR	0.55	6.8	0.91	3.42

**Sub Basin 18 (SB18)**

BASIN CHARACTERISTICS				TIME OF CONCENTRATION						RESULTS					
	Area, ac	% imp	Soil Type	Overland Flow - Surface Type 1		Overland Flow - Surface Type 2		Channel Flow		Tc, min	Event	C	i, in/hr	A, acres	Q, cfs
Landscape	0.08	2%	C	Surface Imperviousness	0.5	Surface Imperviousness	0.02	Land Surface	Short Pature and Lawns	Minimum	1.25 YR	0.34	1.6	0.16	0.09
Asphalt Parking & Walkways	0.08	100%		Length, ft	130	Length, ft	0	Length, ft	0	Tc, min	2-YR	0.34	2.3	0.16	0.12
Roof	0.00	90%	P2	Slope, percent	10.0000	Slope, percent	1.0000	Slope, ft/ft	1.0000	5.0	5-YR	0.40	3.4	0.16	0.22
Gravel	0.00	0%		1.4	Runoff Coefficient	0.4	Runoff Coefficient	0.162	Conveyance Coefficient	7	Final	10-YR	0.46	4.3	0.16
Other	0.00	0%						Velocity, ft/s	7.0	Tc, min	25-YR	0.53	5.5	0.16	0.47
				Ti, min=	6.7	Ti, min=	0.0	Tt, min=	0.0	6.7	100-YR	0.61	7.4	0.16	0.71

**Sub Basin 19 (SB19)**

BASIN CHARACTERISTICS				TIME OF CONCENTRATION						RESULTS					
	Area, ac	% imp	Soil Type	Overland Flow - Surface Type 1		Overland Flow - Surface Type 2		Channel Flow		Tc, min	Event	C	i, in/hr	A, acres	Q, cfs
Landscape	0.17	2%	C	Surface Imperviousness	0.6	Surface Imperviousness	0.02	Land Surface	Paved Areas and Shallow Swales	Minimum	1.25 YR	0.43	1.5	0.48	0.30
Asphalt Parking & Walkways	0.20	100%		Length, ft	175	Length, ft	0	Length, ft	300	Tc, min	2-YR	0.43	2.1	0.48	0.43
Roof	0.11	90%	P2	Slope, percent	10.0000	Slope, percent	1.0000	Slope, ft/ft	0.0500	5.0	5-YR	0.48	3.1	0.48	0.71
Gravel	0.00	0%		1.4	Runoff Coefficient	0.46	Runoff Coefficient	0.162	Conveyance Coefficient	20	Final	10-YR	0.53	4.0	0.48
Other	0.00	0%						Velocity, ft/s	4.5	Tc, min	25-YR	0.58	5.1	0.48	1.43
				Ti, min=	7.1	Ti, min=	0.0	Tt, min=	1.1	8.2	100-YR	0.64	6.8	0.48	2.11

**Sub Basin 20 (SB20)**

BASIN CHARACTERISTICS				TIME OF CONCENTRATION						RESULTS					
	Area, ac	% imp	Soil Type	Overland Flow - Surface Type 1		Overland Flow - Surface Type 2		Channel Flow		Tc, min	Event	C	i, in/hr	A, acres	Q, cfs
Landscape	1.22	2%	C	Surface Imperviousness	0.05	Surface Imperviousness	0.02	Land Surface	Short Pature and Lawns	Minimum	1.25 YR	0.08	1.7	1.27	0.18
Asphalt Parking & Walkways	0.05	100%		Length, ft	100	Length, ft	0	Length, ft	0	Tc, min	2-YR	0.08	2.5	1.27	0.26
Roof	0.00	90%	P2	Slope, percent	40.0000	Slope, percent	1.0000	Slope, ft/ft	1.0000	5.0	5-YR	0.19	3.7	1.27	0.88
Gravel	0.00	0%		1.4	Runoff Coefficient	0.18	Runoff Coefficient	0.162	Conveyance Coefficient	7	Final	10-YR	0.28	4.7	1.27
Other	0.00	0%						Velocity, ft/s	7.0	Tc, min	25-YR	0.40	6.1	1.27	3.07
				Ti, min=	4.8	Ti, min=	0.0	Tt, min=	0.0	5.0	100-YR	0.52	8.2	1.27	5.38

**Sub Basin 21 (SB21)**

BASIN CHARACTERISTICS				TIME OF CONCENTRATION						RESULTS				
-----------------------	--	--	--	-----------------------	--	--	--	--	--	---------	--	--	--	--

**RATIONAL METHOD RUNOFF ANALYSIS**

Job # 1992-001 Date: April 13, 2021  
 Job Name Copper Ridge Revised:  
 Designed by: JLW

	Area, ac	% imp	Soil Type	Overland Flow - Surface Type 1		Overland Flow - Surface Type 2		Channel Flow		Tc, min	Event	C	i, in/hr	A, acres	Q, cfs
				Surface Imperviousness	Length, ft	Surface Imperviousness	Length, ft	Land Surface	Channel Flow						
Landscape	0.12	2%	C	0.75	225	0.02	0	Land Surface	Short Pature and Lawns	Minimum	1.25 YR	0.56	1.5	0.55	0.46
Asphalt Parking & Walkways	0.31	100%		0.225	200	0	0	Length, ft	0	Tc, min	2-YR	0.56	2.2	0.55	0.67
Roof	0.12	90%	P2	7.0000	7.0000	1.0000	1.0000	Slope, ft/ft	1.0000	5.0	5-YR	0.59	3.3	0.55	1.05
Gravel	0.00	0%		1.4	0.58	0.162	0.162	0.162	Conveyance Coefficient	7	Final	10-YR	0.63	4.1	0.55
Other	0.00	0%	Runoff Coefficient		0.58	0.162	0.162	0.162	Velocity, ft/s	7.0	Tc, min	25-YR	0.67	5.3	0.55
				Ti, min=	7.3	Ti, min=	0.0	Tt, min=	0.0	7.3	100-YR	0.72	7.1	0.55	2.81

**Sub Basin 22 (SB22)**

BASIN CHARACTERISTICS				TIME OF CONCENTRATION						RESULTS					
	Area, ac	% imp	Soil Type	Overland Flow - Surface Type 1		Overland Flow - Surface Type 2		Channel Flow		Tc, min	Event	C	i, in/hr	A, acres	Q, cfs
				Surface Imperviousness	Length, ft	Surface Imperviousness	Length, ft	Land Surface	Channel Flow						
Landscape	0.03	2%	C	0.8	200	0.02	0	Land Surface	Short Pature and Lawns	Minimum	1.25 YR	0.61	1.6	0.16	0.16
Asphalt Parking & Walkways	0.13	100%		0.8	200	0	0	Length, ft	0	Tc, min	2-YR	0.61	2.3	0.16	0.23
Roof	0.00	90%	P2	7.0000	7.0000	1.0000	1.0000	Slope, ft/ft	1.0000	5.0	5-YR	0.64	3.4	0.16	0.35
Gravel	0.00	0%		1.4	0.63	0.162	0.162	0.162	Conveyance Coefficient	7	Final	10-YR	0.68	4.4	0.16
Other	0.00	0%	Runoff Coefficient		0.63	0.162	0.162	0.162	Velocity, ft/s	7.0	Tc, min	25-YR	0.72	5.7	0.16
				Ti, min=	6.3	Ti, min=	0.0	Tt, min=	0.0	6.3	100-YR	0.76	7.6	0.16	0.91

**Sub Basin 23 (SB23)**

BASIN CHARACTERISTICS				TIME OF CONCENTRATION						RESULTS					
	Area, ac	% imp	Soil Type	Overland Flow - Surface Type 1		Overland Flow - Surface Type 2		Channel Flow		Tc, min	Event	C	i, in/hr	A, acres	Q, cfs
				Surface Imperviousness	Length, ft	Surface Imperviousness	Length, ft	Land Surface	Channel Flow						
Landscape	0.46	2%	C	0.02	120	0.95	175	Land Surface	Paved Areas and Shallow Swales	Minimum	1.25 YR	0.31	1.4	0.86	0.37
Asphalt Parking & Walkways	0.17	100%		0.02	120	0.95	175	Length, ft	50	Tc, min	2-YR	0.31	2.0	0.86	0.53
Roof	0.23	90%	P2	50.0000	50.0000	5.0000	5.0000	Slope, ft/ft	0.0700	5.0	5-YR	0.37	3.0	0.86	0.96
Gravel	0.00	0%		1.4	0.162	0.82	0.82	0.82	Conveyance Coefficient	20	Final	10-YR	0.44	3.8	0.86
Other	0.00	0%	Runoff Coefficient		0.162	0.82	0.82	0.82	Velocity, ft/s	5.3	Tc, min	25-YR	0.51	4.9	0.86
				Ti, min=	5.0	Ti, min=	3.9	Tt, min=	0.2	9.1	100-YR	0.59	6.6	0.86	3.34

**Sub Basin 24 (SB24)**

BASIN CHARACTERISTICS				TIME OF CONCENTRATION						RESULTS					
	Area, ac	% imp	Soil Type	Overland Flow - Surface Type 1		Overland Flow - Surface Type 2		Channel Flow		Tc, min	Event	C	i, in/hr	A, acres	Q, cfs
				Surface Imperviousness	Length, ft	Surface Imperviousness	Length, ft	Land Surface	Channel Flow						
Landscape	0.23	2%	C	0.5	150	0.02	0	Land Surface	Paved Areas and Shallow Swales	Minimum	1.25 YR	0.34	1.5	0.48	0.24
Asphalt Parking & Walkways	0.09	100%		0.5	150	0.02	0	Length, ft	60	Tc, min	2-YR	0.34	2.2	0.48	0.35
Roof	0.16	90%	P2	10.0000	10.0000	1.0000	1.0000	Slope, ft/ft	0.0700	5.0	5-YR	0.40	3.2	0.48	0.62
Gravel	0.00	0%		1.4	0.4	0.162	0.162	0.162	Conveyance Coefficient	20	Final	10-YR	0.46	4.1	0.48
Other	0.00	0%	Runoff Coefficient		0.4	0.162	0.162	0.162	Velocity, ft/s	5.3	Tc, min	25-YR	0.53	5.3	0.48
				Ti, min=	7.2	Ti, min=	0.0	Tt, min=	0.2	7.4	100-YR	0.60	7.1	0.48	2.06

**Sub Basin 25 (SB25)**

BASIN CHARACTERISTICS				TIME OF CONCENTRATION						RESULTS					
	Area, ac	% imp	Soil Type	Overland Flow - Surface Type 1		Overland Flow - Surface Type 2		Channel Flow		Tc, min	Event	C	i, in/hr	A, acres	Q, cfs
				Surface Imperviousness	Length, ft	Surface Imperviousness	Length, ft	Land Surface	Channel Flow						
Landscape	0.01	2%	C	0.65	60	0.02	0	Land Surface	Short Pature and Lawns	Minimum	1.25 YR	0.47	1.7	0.03	0.02
Asphalt Parking & Walkways	0.02	100%		0.65	60	0.02	0	Length, ft	0	Tc, min	2-YR	0.47	2.5	0.03	0.03
Roof	0.00	90%	P2	7.0000	7.0000	1.0000	1.0000	Slope, ft/ft	1.0000	5.0	5-YR	0.51	3.7	0.03	0.06
Gravel	0.00	0%		1.4	0.49	0.162	0.162	0.162	Conveyance Coefficient	7	Final	10-YR	0.56	4.7	0.03
Other	0.00	0%	Runoff Coefficient		0.49	0.162	0.162	0.162	Velocity, ft/s	7.0	Tc, min	25-YR	0.61	6.1	0.03
				Ti, min=	4.4	Ti, min=	0.0	Tt, min=	0.0	5.0	100-YR	0.66	8.2	0.03	0.16

**Sub Basin 26 (SB26)**

BASIN CHARACTERISTICS				TIME OF CONCENTRATION						RESULTS					
	Area, ac	% imp	Soil Type	Overland Flow - Surface Type 1		Overland Flow - Surface Type 2		Channel Flow		Tc, min	Event	C	i, in/hr	A, acres	Q, cfs
				Surface Imperviousness	Length, ft	Surface Imperviousness	Length, ft	Land Surface	Channel Flow						
Landscape	0.10	2%	C	0.3	0	0.02	0	Land Surface	Paved Areas and Shallow Swales	Minimum	1.25 YR	0.41	1.7	0.25	0.18
Asphalt Parking & Walkways	0.00	100%		0.3	0	0.02	0	Length, ft	0	Tc, min	2-YR	0.41	2.5	0.25	0.18
Roof	0.00	90%	P2	7.0000	7.0000	1.0000	1.0000	Slope, ft/ft	1.0000	5.0	5-YR	0.51	3.7	0.03	0.06
Gravel	0.00	0%		1.4	0.49	0.162	0.162	0.162	Conveyance Coefficient	7	Final	10-YR	0.56	4.7	0.03
Other	0.00	0%	Runoff Coefficient		0.49	0.162	0.162	0.162	Velocity, ft/s	7.0	Tc, min	25-YR	0.61	6.1	0.03
				Ti, min=	4.4	Ti, min=	0.0	Tt, min=	0.0	5.0	100-YR	0.66	8.2	0.03	0.16

**RATIONAL METHOD RUNOFF ANALYSIS**

Job # 1992-001 Date: April 13, 2021  
 Job Name Copper Ridge Revised:  
 Designed by: JLW

Asphalt Parking & Walkways	0.15	100%	P2	Length, ft	50	Length, ft	0	Length, ft	140	Tc, min	2-YR	0.41	2.5	0.25	0.26	
Roof	0.00	90%		Slope, percent	25.0000	Slope, percent	1.0000	Slope, ft/ft	0.0200	5.0	5-YR	0.46	3.7	0.25	0.43	
Gravel	0.00	0%		1.4	Runoff Coefficient	0.3	Runoff Coefficient	0.162	Conveyance Coefficient	20	Final	10-YR	0.51	4.7	0.25	0.61
Other	0.00	0%			Velocity, ft/s	2.8	Tc, min	25-YR	0.57	6.1	0.25	0.87				
	0.25	61%		Ti, min=	3.5	Ti, min=	0.0	Tt, min=	0.8	5.0	100-YR	0.64	8.2	0.25	1.30	

**Sub Basin 27 (SB27)**

BASIN CHARACTERISTICS				TIME OF CONCENTRATION						RESULTS					
	Area, ac	% imp	Soil Type	Overland Flow - Surface Type 1		Overland Flow - Surface Type 2		Channel Flow		Tc, min	Event	C	i, in/hr	A, acres	Q, cfs
Landscape	0.11	2%	C	Surface Imperviousness	0.75	Surface Imperviousness	0.02	Land Surface	Paved Areas and Shallow Swales	Minimum	1.25 YR	0.56	1.7	0.57	0.54
Asphalt Parking & Walkways	0.22	100%		Length, ft	100	Length, ft	0	Length, ft	140	Tc, min	2-YR	0.56	2.4	0.57	0.77
Roof	0.24	90%	P2	Slope, percent	8.0000	Slope, percent	1.0000	Slope, ft/ft	0.0200	5.0	5-YR	0.59	3.6	0.57	1.22
Gravel	0.00	0%		1.4	Runoff Coefficient	0.58	Runoff Coefficient	0.162	Conveyance Coefficient	20	Final	10-YR	0.63	4.6	0.57
Other	0.00	0%	Velocity, ft/s		2.8	Tc, min	25-YR	0.68	5.9	0.57	2.27				
	0.57	77%	Ti, min=	4.7	Ti, min=	0.0	Tt, min=	0.8	5.5	100-YR	0.72	7.9	0.57	3.24	

**Sub Basin 28 (SB28)**

BASIN CHARACTERISTICS				TIME OF CONCENTRATION						RESULTS					
	Area, ac	% imp	Soil Type	Overland Flow - Surface Type 1		Overland Flow - Surface Type 2		Channel Flow		Tc, min	Event	C	i, in/hr	A, acres	Q, cfs
Landscape	0.00	2%	C	Surface Imperviousness	1	Surface Imperviousness	0.02	Land Surface	Short Pature and Lawns	Minimum	1.25 YR	0.89	1.7	0.02	0.03
Asphalt Parking & Walkways	0.02	100%		Length, ft	40	Length, ft	0	Length, ft	0	Tc, min	2-YR	0.89	2.5	0.02	0.04
Roof	0.00	90%	P2	Slope, percent	2.0000	Slope, percent	1.0000	Slope, ft/ft	1.0000	5.0	5-YR	0.90	3.7	0.02	0.07
Gravel	0.00	0%		1.4	Runoff Coefficient	0.9	Runoff Coefficient	0.162	Conveyance Coefficient	7	Final	10-YR	0.92	4.7	0.02
Other	0.00	0%	Velocity, ft/s		7.0	Tc, min	25-YR	0.94	6.1	0.02	0.11				
	0.02	100%	Ti, min=	1.8	Ti, min=	0.0	Tt, min=	0.0	5.0	100-YR	0.96	8.2	0.02	0.16	

**Sub Basin 29 (SB29)**

BASIN CHARACTERISTICS				TIME OF CONCENTRATION						RESULTS					
	Area, ac	% imp	Soil Type	Overland Flow - Surface Type 1		Overland Flow - Surface Type 2		Channel Flow		Tc, min	Event	C	i, in/hr	A, acres	Q, cfs
Landscape	0.13	2%	C	Surface Imperviousness	0.02	Surface Imperviousness	0.02	Land Surface	Paved Areas and Shallow Swales	Minimum	1.25 YR	0.14	1.0	0.15	0.02
Asphalt Parking & Walkways	0.02	100%		Length, ft	50	Length, ft	200	Length, ft	20	Tc, min	2-YR	0.14	1.5	0.15	0.03
Roof	0.00	90%	P2	Slope, percent	50.0000	Slope, percent	5.0000	Slope, ft/ft	0.0200	5.0	5-YR	0.24	2.2	0.15	0.08
Gravel	0.00	0%		1.4	Runoff Coefficient	0.162	Runoff Coefficient	0.162	Conveyance Coefficient	20	Final	10-YR	0.32	2.8	0.15
Other	0.00	0%	Velocity, ft/s		2.8	Tc, min	25-YR	0.43	3.6	0.15	0.23				
	0.15	15%	Ti, min=	3.2	Ti, min=	14.0	Tt, min=	0.1	17.3	100-YR	0.54	4.8	0.15	0.39	

**Sub Basin 30 (SB30)**

BASIN CHARACTERISTICS				TIME OF CONCENTRATION						RESULTS					
	Area, ac	% imp	Soil Type	Overland Flow - Surface Type 1		Overland Flow - Surface Type 2		Channel Flow		Tc, min	Event	C	i, in/hr	A, acres	Q, cfs
Landscape	0.15	2%	C	Surface Imperviousness	0.65	Surface Imperviousness	0.3	Land Surface	Grassed Waterways	Minimum	1.25 YR	0.47	1.3	0.53	0.33
Asphalt Parking & Walkways	0.14	100%		Length, ft	250	Length, ft	0	Length, ft	0	Tc, min	2-YR	0.47	1.9	0.53	0.48
Roof	0.24	90%	P2	Slope, percent	5.0000	Slope, percent	5.0000	Slope, ft/ft	1.0000	5.0	5-YR	0.51	2.9	0.53	0.78
Gravel	0.00	0%		1.4	Runoff Coefficient	0.49	Runoff Coefficient	0.3	Conveyance Coefficient	15	Final	10-YR	0.56	3.6	0.53
Other	0.00	0%	Velocity, ft/s		15.0	Tc, min	25-YR	0.61	4.7	0.53	1.52				
	0.53	68%	Ti, min=	10.2	Ti, min=	0.0	Tt, min=	0.0	10.2	100-YR	0.67	6.3	0.53	2.21	

**Part of DB3, and SBs 1 & 2 For access culvert desing**

BASIN CHARACTERISTICS				TIME OF CONCENTRATION						RESULTS					
	Area, ac	% imp	Soil Type	Overland Flow - Surface Type 1		Overland Flow - Surface Type 2		Channel Flow		Tc, min	Event	C	i, in/hr	A, acres	Q, cfs
Landscape	1.66	2%	C	Surface Imperviousness	0.15	Surface Imperviousness	0.02	Land Surface	Paved Areas and Shallow Swales	Minimum	1.25 YR	0.13	1.5	1.86	0.34
Asphalt Parking & Walkways	0.20	100%		Length, ft	260	Length, ft	0	Length, ft	250	Tc, min	2-YR	0.13	2.1	1.86	0.49
Roof	0.00	90%	P2	Slope, percent	40.0000	Slope, percent	5.0000	Slope, ft/ft	0.0700	5.0	5-YR	0.22	3.1	1.86	1.30

**RATIONAL METHOD RUNOFF ANALYSIS**

Job # 1992-001 Date: April 13, 2021  
 Job Name Copper Ridge Revised:  
 Designed by: JLW

Gravel	0.00	0%	1.4	Runoff Coefficient	0.24	Runoff Coefficient	0.162	Conveyance Coefficient	20	Final	10-YR	0.31	4.0	1.86	2.33
Other	0.00	0%		Ti, min=	7.3	Ti, min=	0.0	Velocity, ft/s	5.3	Tc, min	25-YR	0.42	5.1	1.86	4.03
	1.86	13%		Tt, min=		Tt, min=		0.8	8.1	100-YR	0.54	6.9	1.86	6.87	

**EB1, EB3, EB4, & EB5 Basins tributary to the (2) 36" culvert crossing**

BASIN CHARACTERISTICS				TIME OF CONCENTRATION						RESULTS					
Area, ac	% imp	Soil Type		Overland Flow - Surface Type 1		Overland Flow - Surface Type 2		Channel Flow		Tc, min	Event	C	i, in/hr	A, acres	Q, cfs
Landscape	24.98	2%	C	Surface Imperviousness	0.02	Surface Imperviousness	0.02	Land Surface	Short Pature and Lawns	Minimum	1.25 YR	0.06	0.5	25.21	0.80
Asphalt Parking & Walkways	0.23	100%		Length, ft	300	Length, ft	300	Length, ft	1150	Tc, min	2-YR	0.06	0.7	25.21	1.15
Roof	0.00	90%	P2	Slope, percent	5.0000	Slope, percent	10.0000	Slope, ft/ft	0.0500	5.0	5-YR	0.17	1.1	25.21	4.66
Gravel	0.00	0%	1.4	Runoff Coefficient	0.162	Runoff Coefficient	0.162	Conveyance Coefficient	7	Final	10-YR	0.27	1.4	25.21	9.40
Other	0.00	0%		Velocity, ft/s		Velocity, ft/s		1.6	Tc, min	25-YR	0.38	1.8	25.21	17.39	
	25.21	3%		Ti, min=	17.1	Ti, min=	13.6	Tt, min=	12.2	42.9	100-YR	0.51	2.4	25.21	30.97

**Design Point No. 4 For private drainage ditch design**

BASIN CHARACTERISTICS				TIME OF CONCENTRATION						RESULTS					
Area, ac	% imp	Soil Type		Overland Flow - Surface Type 1		Overland Flow - Surface Type 2		Channel Flow		Tc, min	Event	C	i, in/hr	A, acres	Q, cfs
Landscape	3.41	2%	C	Surface Imperviousness	0.4	Surface Imperviousness	0.02	Land Surface	Grassed Waterways	Minimum	1.25 YR	0.29	0.8	5.89	1.38
Asphalt Parking & Walkways	1.62	100%		Length, ft	250	Length, ft	150	Length, ft	220	Tc, min	2-YR	0.29	1.2	5.89	1.98
Roof	0.86	90%	P2	Slope, percent	5.0000	Slope, percent	5.0000	Slope, ft/ft	0.0700	5.0	5-YR	0.36	1.7	5.89	3.64
Gravel	0.00	0%	1.4	Runoff Coefficient	0.35	Runoff Coefficient	0.162	Conveyance Coefficient	15	Final	10-YR	0.42	2.2	5.89	5.51
Other	0.00	0%		Velocity, ft/s		Velocity, ft/s		4.0	Tc, min	25-YR	0.50	2.8	5.89	8.40	
	5.89	42%		Ti, min=	12.5	Ti, min=	12.1	Tt, min=	0.9	25.5	100-YR	0.59	3.8	5.89	13.11

**Design Point No. 7 For culvert crossing**

BASIN CHARACTERISTICS				TIME OF CONCENTRATION						RESULTS					
Area, ac	% imp	Soil Type		Overland Flow - Surface Type 1		Overland Flow - Surface Type 2		Channel Flow		Tc, min	Event	C	i, in/hr	A, acres	Q, cfs
Landscape	3.24	2%	C	Surface Imperviousness	0.4	Surface Imperviousness	0.02	Land Surface	Grassed Waterways	Minimum	1.25 YR	0.28	0.8	5.41	1.24
Asphalt Parking & Walkways	1.42	100%		Length, ft	250	Length, ft	150	Length, ft	100	Tc, min	2-YR	0.28	1.2	5.41	1.78
Roof	0.75	90%	P2	Slope, percent	5.0000	Slope, percent	5.0000	Slope, ft/ft	0.0700	5.0	5-YR	0.35	1.8	5.41	3.31
Gravel	0.00	0%	1.4	Runoff Coefficient	0.35	Runoff Coefficient	0.162	Conveyance Coefficient	15	Final	10-YR	0.42	2.2	5.41	5.04
Other	0.00	0%		Velocity, ft/s		Velocity, ft/s		4.0	Tc, min	25-YR	0.50	2.9	5.41	7.74	
	5.41	40%		Ti, min=	12.5	Ti, min=	12.1	Tt, min=	0.4	25.0	100-YR	0.58	3.9	5.41	12.14

D. PLDP Sizing Calculations for Detention

### Design Procedure Form: 5 Year Detention Pond Calculations

<b>Designer:</b>	JLW						
<b>Company:</b>	FOUR POINTS						
<b>Date:</b>	4/13/2021						
<b>Project:</b>	Copper Ridge						
<b>Location:</b>	Gloria Gossard Blvd						
<b>5 Year Detention Pond</b>							
	Area	8.84	acres				
	Allowable Release Rate Major Storm						
	(0.10 cfs/acre) * A		=	0.884	(from table 5.11.1)		
	C <sub>5</sub>	0.36			(from table 5.6.1)		
	i <sub>5</sub>	2.3			(from table 5.5.1)		
	Tc (dev)	15.8					
	Equation 5.11.1						
	<b>Volume In</b>						
	V= C*1*A*Tc(dev)*60	6938.905			(from equation 5.11.1)		
		6939	ft <sup>3</sup>				
	Equation 5.11.2						
	<b>Volume Out</b>						
	V=Qallow*Tc(ex)*(60)	838.032			(from equation 5.11.2)		
		838	ft <sup>3</sup>				
	<b>Pond Volume</b>						
	Volume In - Volume Out						
		6101	ft <sup>3</sup>	0.1401	acre-ft		
	Depth	2	ft				
	Area	3050.436		3050	sq-ft		
	Minor Storm Water Surface=	6658	ft				



## Discharge Rates for Major and Minor Storms

Designer: Joe Wiedemeier  
Company: Four Points  
Date: 4/13/2021  
Project: Copper Ridge Village  
Location:

### Oriface Plate Size for Minor Storm

Area of Orifice Plate=	0.083 sq-ft
$C_d$	0.65
Diameter of Opening	0.325 ft
	<b>3.89 in</b>
Depth of surface(major)	4.2 ft
Flow line of Orifice Plate	6653.80

Discharge for Minor Storm Headwater

$Q=CdA(2gh)^{(1/2)}$  0.88 cfs

$Q_{wier}$  3.89 cfs

### Oriface Plate Size for Major Storm

Area of Orifice Plate=	0.45 sq-ft
Diameter of Opening	0.754 ft
	<b>9.05 in</b>

# Weir Report

## Porous Landscape Detention Pond Emergency Overflow - Weir Calc for Major Event

### Rectangular Weir

Crest = Broad  
Bottom Length (ft) = 10.00  
Total Depth (ft) = 1.00

### Highlighted

Depth (ft) = 1.00  
Q (cfs) = 26.00  
Area (sqft) = 10.00  
Velocity (ft/s) = 2.60  
Top Width (ft) = 10.00

### Calculations

Weir Coeff. Cw = 2.60  
Compute by: Q vs Depth  
No. Increments = 10

Depth (ft) Porous Landscape Detention Pond Emergency Overflow - Weir Calc for Major Event Depth (ft)

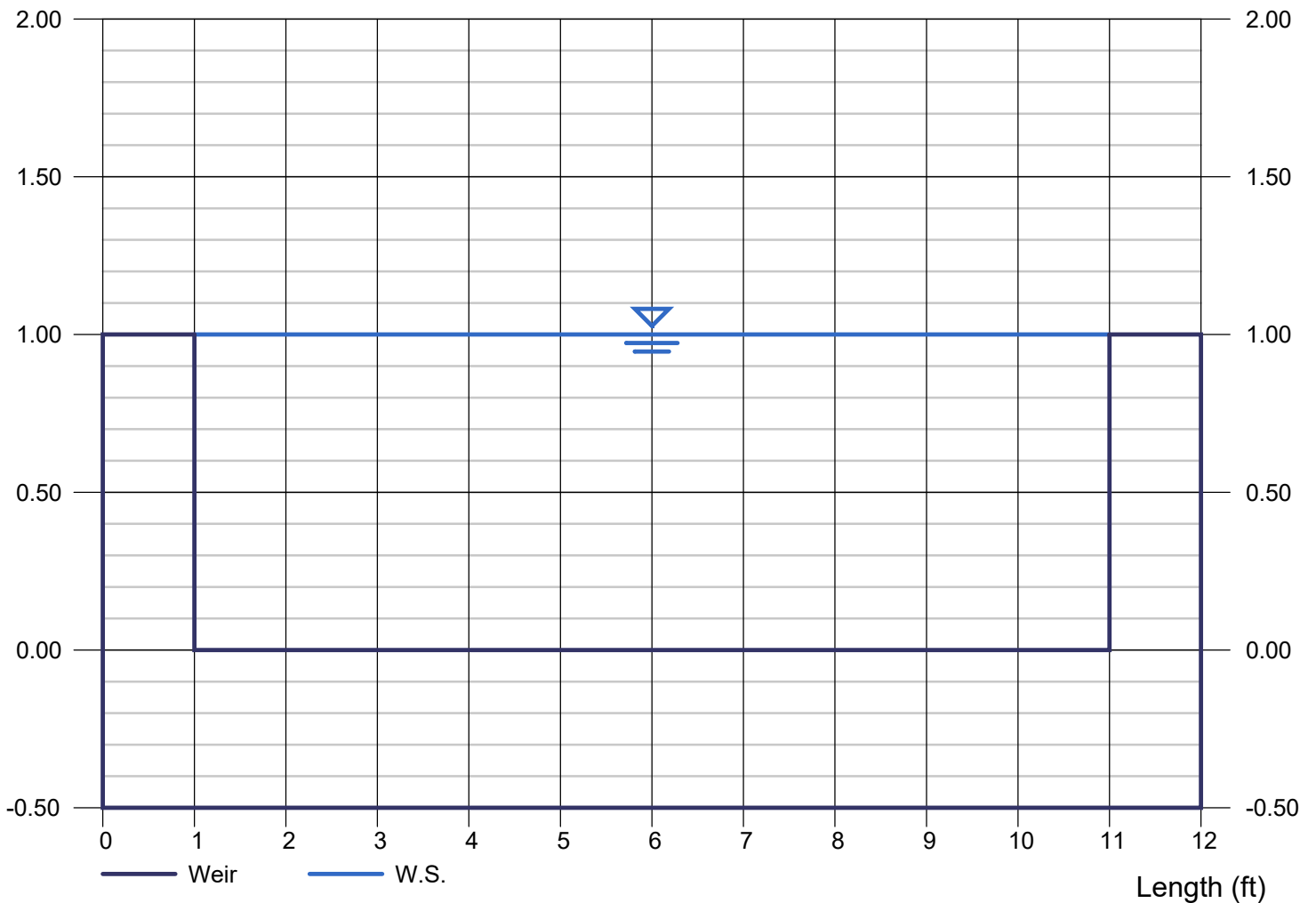

E. Sand Filter Sizing Calculations for Water Quality

## Design Procedure Form: Sand Filter (SF)

UD-BMP (Version 3.07, March 2018)

Sheet 1 of 2

**Designer:** Joe Wiedemeier  
**Company:** Four Points  
**Date:** April 14, 2021  
**Project:** Copper Ridge  
**Location:** Gloria Gossard Blvd

<p>1. Basin Storage Volume</p> <p>A) Effective Imperviousness of Tributary Area, <math>I_a</math> (100% if all paved and roofed areas upstream of sand filter)</p> <p>B) Tributary Area's Imperviousness Ratio (<math>i = I_a/100</math>)</p> <p>C) Water Quality Capture Volume (WQCV) Based on 12-hour Drain Time <math>WQCV = 0.8 * (0.91 * i^3 - 1.19 * i^2 + 0.78 * i)</math></p> <p>D) Contributing Watershed Area (including sand filter area)</p> <p>E) Water Quality Capture Volume (WQCV) Design Volume <math>V_{WQCV} = WQCV / 12 * Area</math></p> <p>F) For Watersheds Outside of the Denver Region, Depth of Average Runoff Producing Storm</p> <p>G) For Watersheds Outside of the Denver Region, Water Quality Capture Volume (WQCV) Design Volume</p> <p>H) User Input of Water Quality Capture Volume (WQCV) Design Volume (Only if a different WQCV Design Volume is desired)</p>	<p><math>I_a = </math> <input style="width: 50px;" type="text" value="44.0"/> %</p> <p><math>i = </math> <input style="width: 50px;" type="text" value="0.440"/></p> <p>WQCV = <input style="width: 50px;" type="text" value="0.15"/> watershed inches</p> <p>Area = <input style="width: 50px;" type="text" value="385,000"/> sq ft</p> <p><math>V_{WQCV} = </math> <input style="width: 50px;" type="text" value=""/></p> <p><math>d_b = </math> <input style="width: 50px;" type="text" value="0.34"/> in</p> <p><math>V_{WQCV\ OTHER} = </math> <input style="width: 50px;" type="text" value="3,863"/> cu ft</p> <p><math>V_{WQCV\ USER} = </math> <input style="width: 50px;" type="text" value=""/> cu ft</p>
<p>2. Basin Geometry</p> <p>A) WQCV Depth</p> <p>B) Sand Filter Side Slopes (Horizontal distance per unit vertical, 4:1 or flatter preferred). Use "0" if sand filter has vertical walls.</p> <p>C) Minimum Filter Area (Flat Surface Area)</p> <p>D) Actual Filter Area</p> <p>E) Volume Provided</p>	<p><math>D_{WQCV} = </math> <input style="width: 50px;" type="text" value="4.0"/> ft</p> <p><math>Z = </math> <input style="width: 50px;" type="text" value="4.00"/> ft / ft</p> <p><math>A_{Min} = </math> <input style="width: 50px;" type="text" value="2118"/> sq ft</p> <p><math>A_{Actual} = </math> <input style="width: 50px;" type="text" value="2150"/> sq ft</p> <p><math>V_T = </math> <input style="width: 50px;" type="text" value="20700"/> cu ft</p>
<p>3. Filter Material</p>	<p>Choose One</p> <p><input checked="" type="radio"/> 18" CDOT Class B or C Filter Material</p> <p><input type="radio"/> Other (Explain):</p> <p>_____</p> <p>_____</p>
<p>4. Underdrain System</p> <p>A) Are underdrains provided?</p> <p>B) Underdrain system orifice diameter for 12 hour drain time</p> <p style="margin-left: 20px;">i) Distance From Lowest Elevation of the Storage Volume to the Center of the Orifice</p> <p style="margin-left: 20px;">ii) Volume to Drain in 12 Hours</p> <p style="margin-left: 20px;">iii) Orifice Diameter, 3/8" Minimum</p>	<p>Choose One</p> <p><input checked="" type="radio"/> YES</p> <p><input type="radio"/> NO</p> <p><math>y = </math> <input style="width: 50px;" type="text" value="4.0"/> ft</p> <p><math>Vol_{12} = </math> <input style="width: 50px;" type="text" value="3,863"/> cu ft</p> <p><math>D_O = </math> <input style="width: 50px;" type="text" value="1 1/4"/> in</p>

**Design Procedure Form: Sand Filter (SF)**

Sheet 2 of 2

**Designer:** Joe Wiedemeier  
**Company:** Four Points  
**Date:** April 14, 2021  
**Project:** Copper Ridge  
**Location:** Gloria Gossard Blvd

5. Impermeable Geomembrane Liner and Geotextile Separator Fabric

A) Is an impermeable liner provided due to proximity of structures or groundwater contamination?

Choose One  
 YES  NO

6. Inlet / Outlet Works

A) Describe the type of energy dissipation at inlet points and means of conveying flows in excess of the WQCV through the outlet

\_\_\_\_\_  
\_\_\_\_\_  
\_\_\_\_\_

Notes: \_\_\_\_\_  
\_\_\_\_\_  
\_\_\_\_\_

F. EGL and HGL Stormwater Conveyance Profiles

# Storm Sewer Profile: B-Line Outlet to B.2

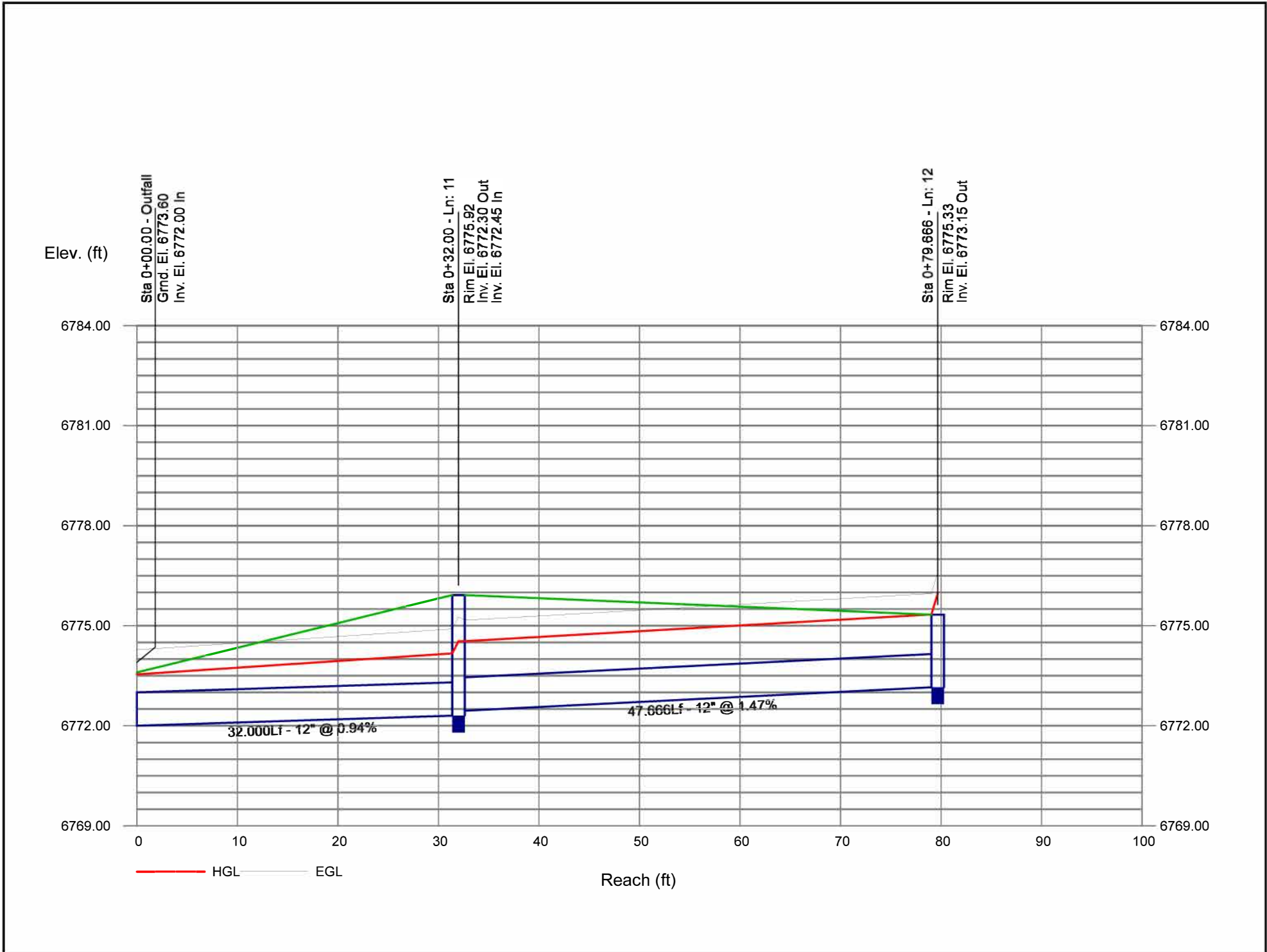

# Storm Sewer Profile: Culvert to Inlet E.A

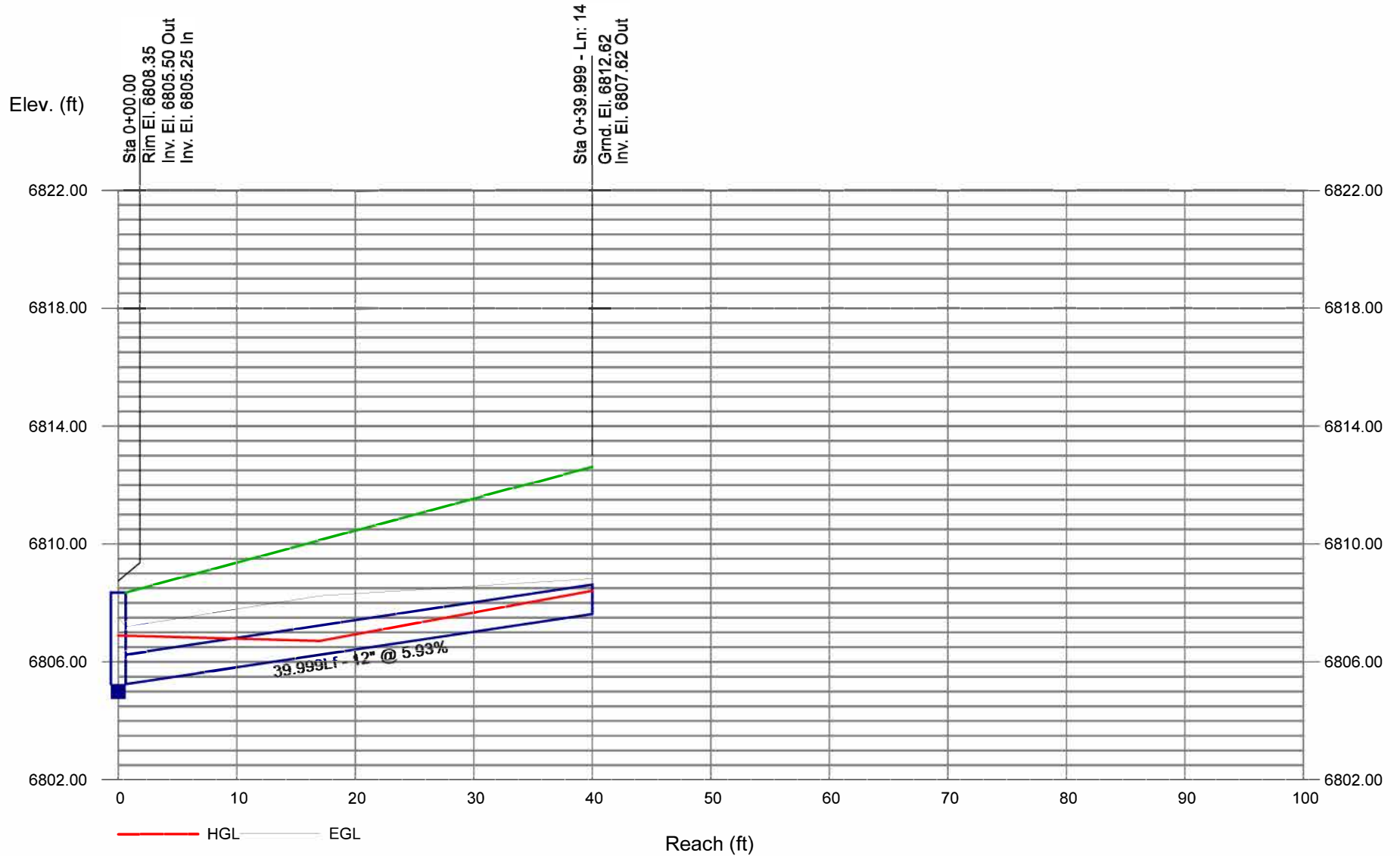

# Storm Sewer Profile: Inlet E.A to E.F

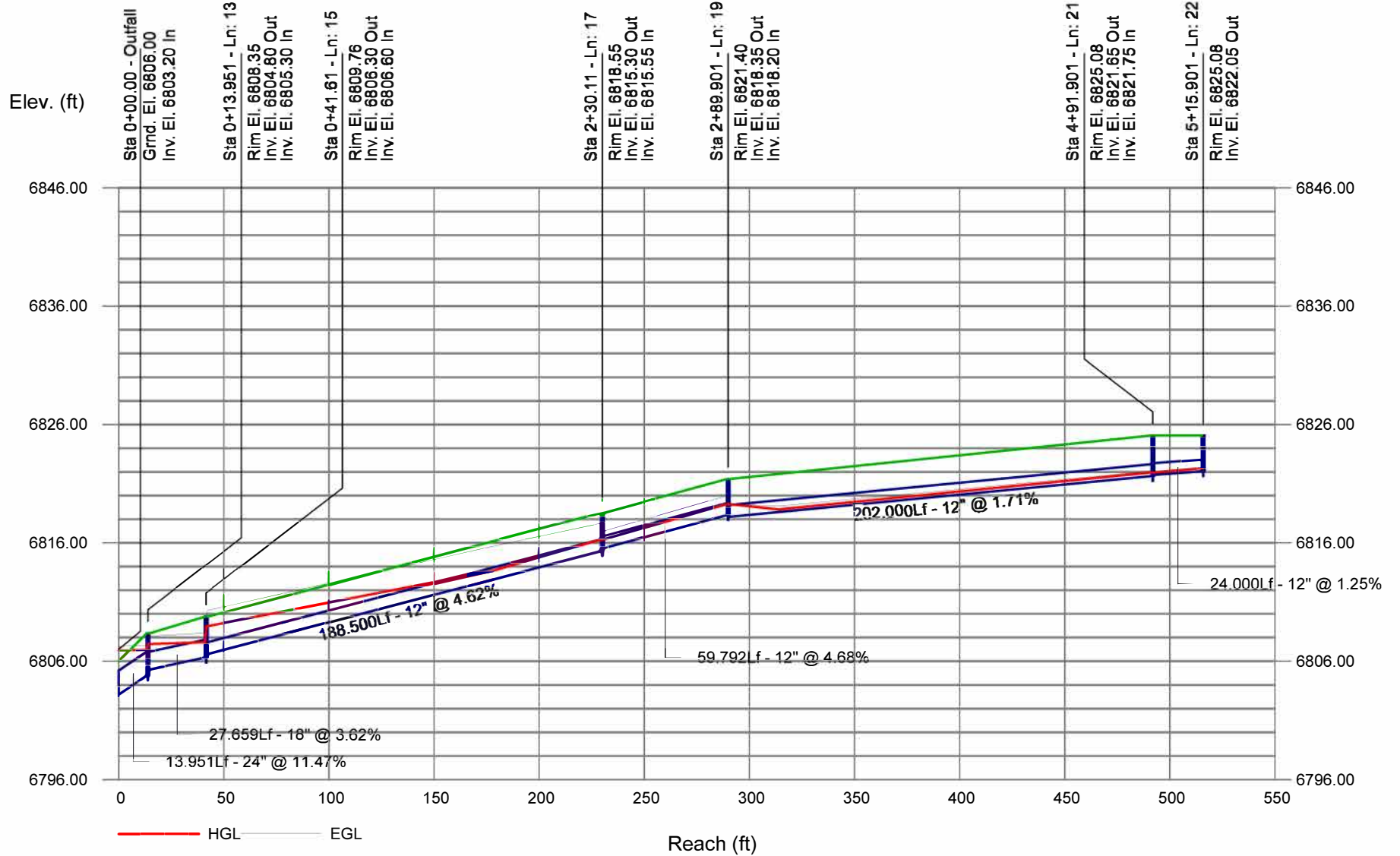

# Storm Sewer Profile: Inlet E.B to E.B.2

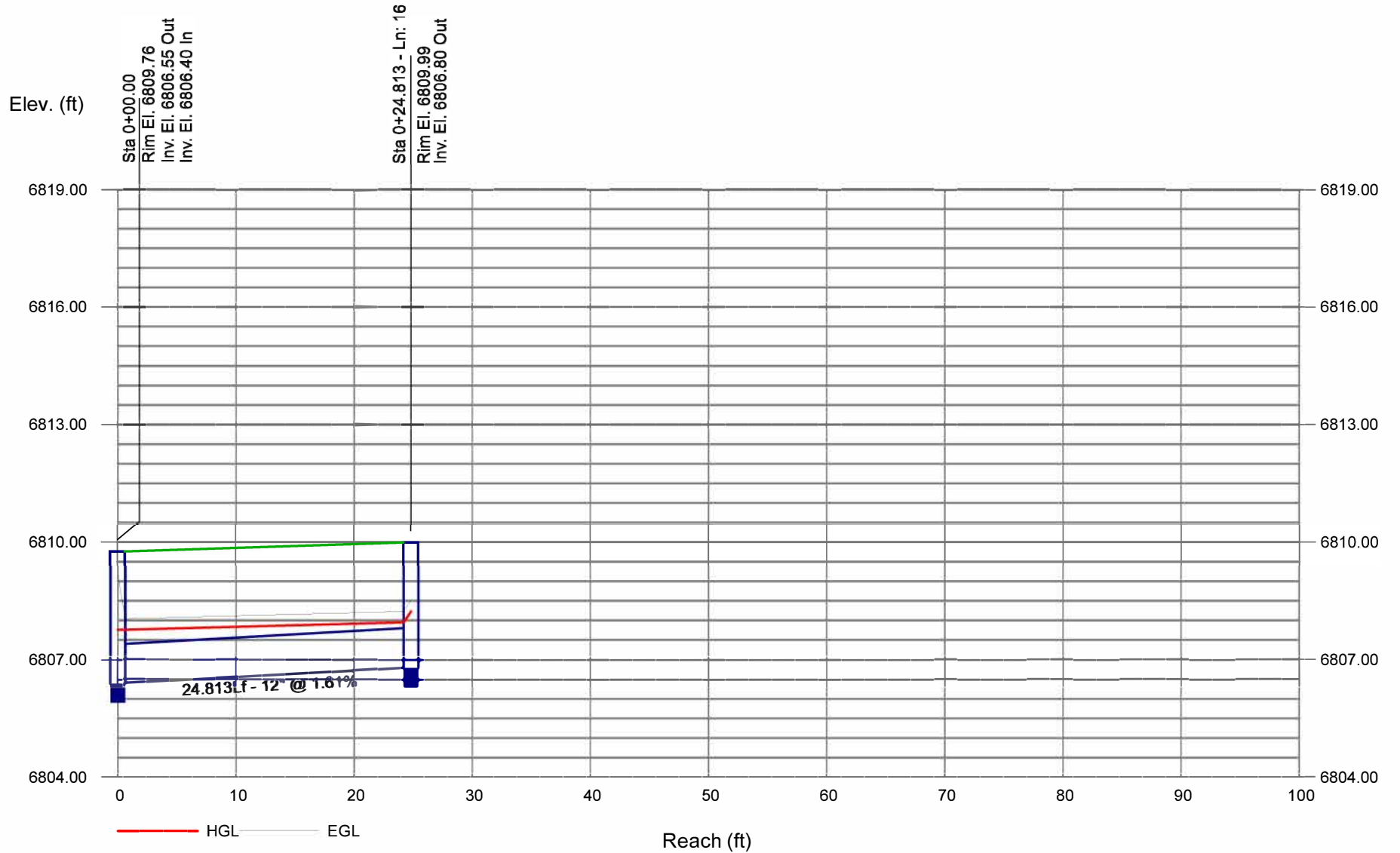

# Storm Sewer Profile: Inlet E.C to E.C.2

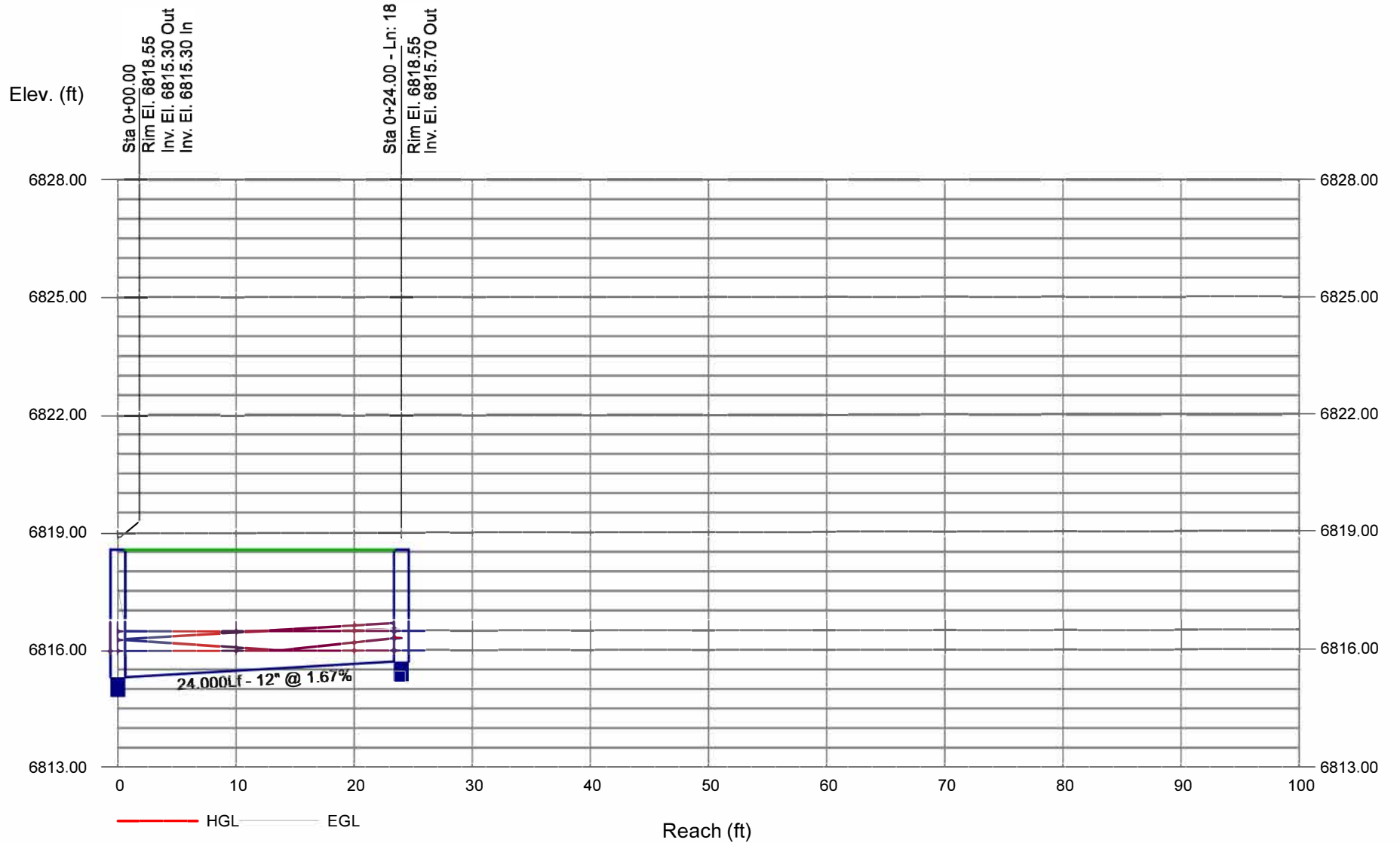

# Storm Sewer Profile: Inlet E.D to E.D.2

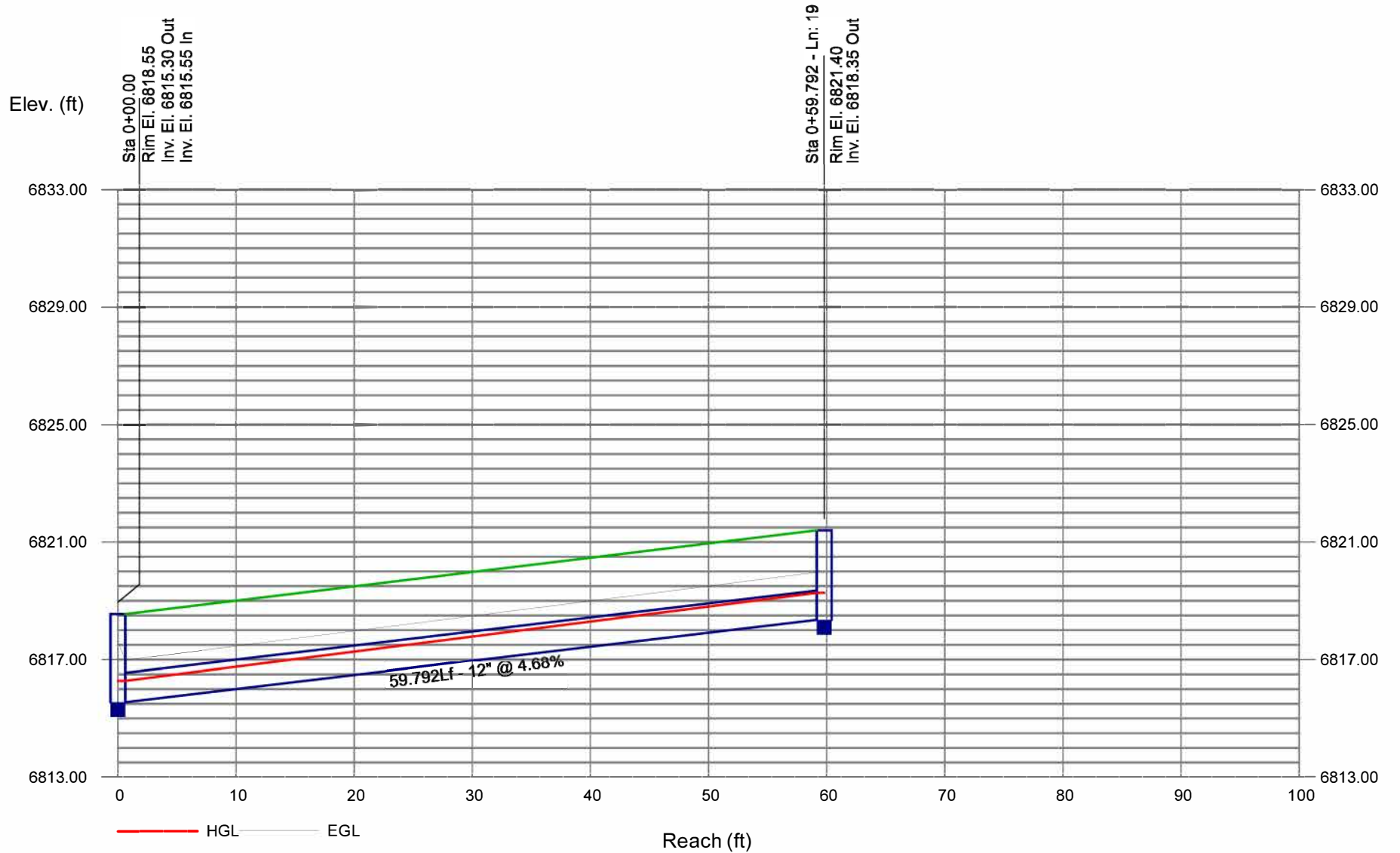

# Storm Sewer Profile: W Line Outlet to W.B.3

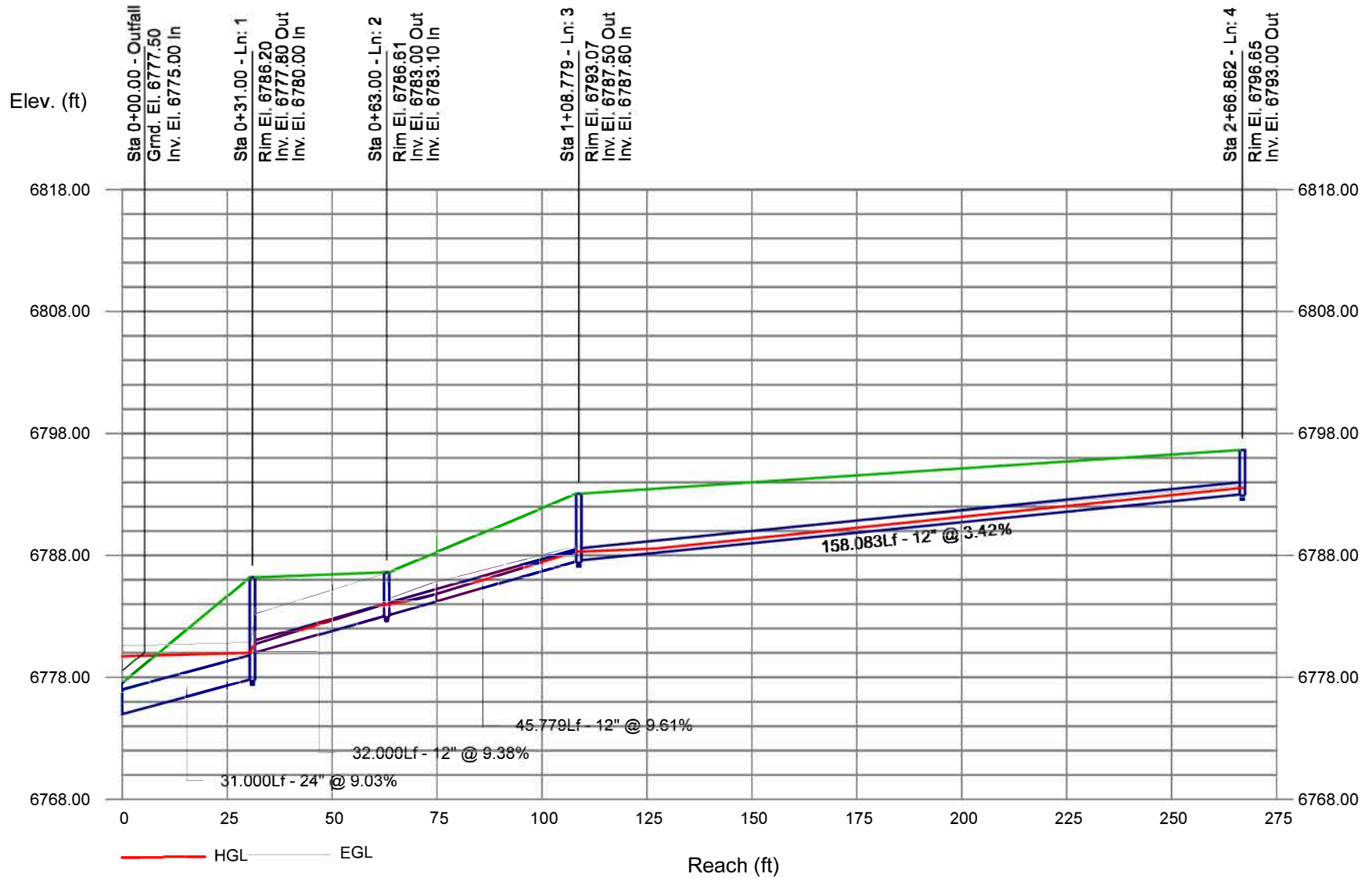

# Storm Sewer Profile: Inlet W.B to W.H

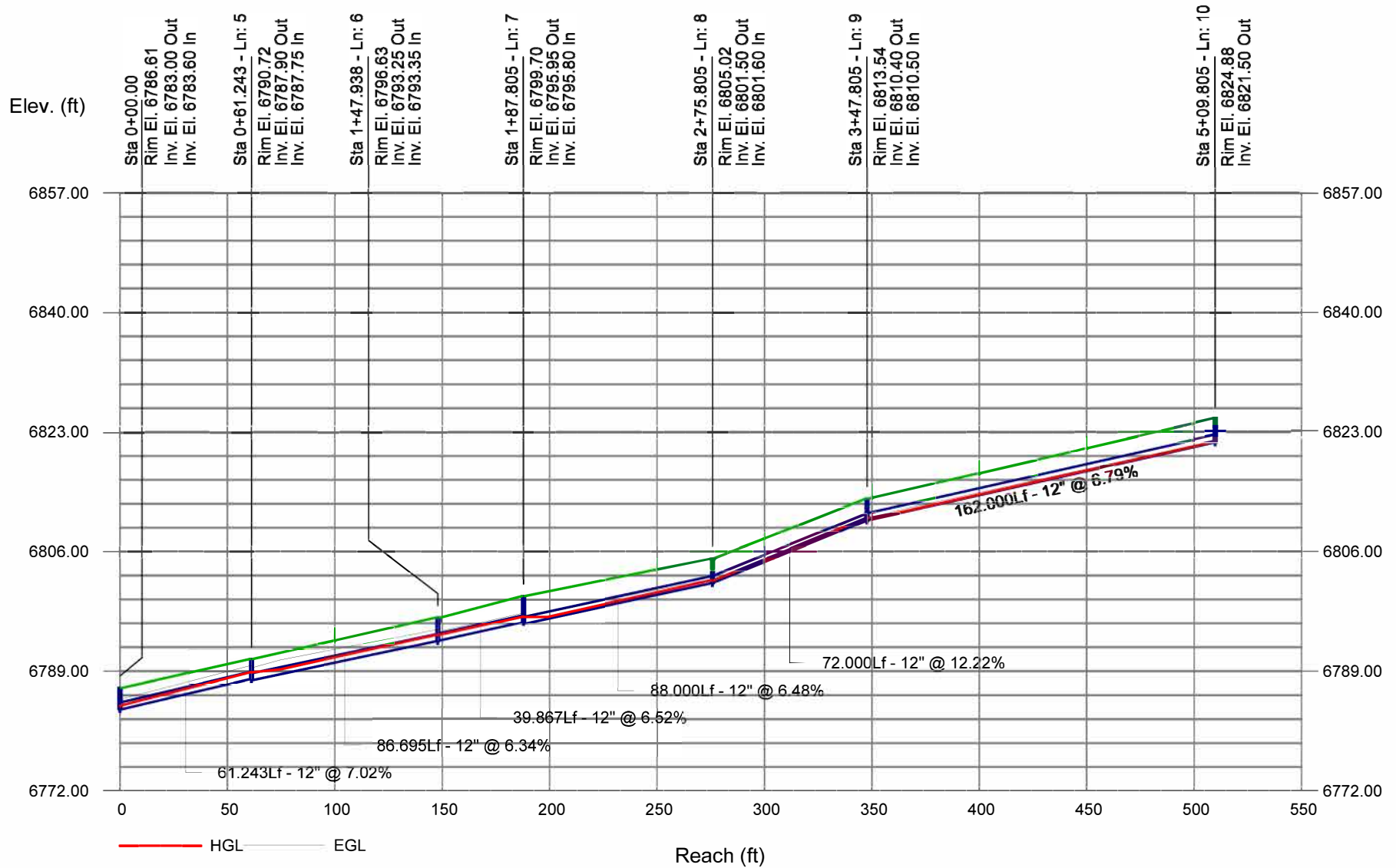

G. Curb and Gutter Calculations

# Channel Report

## Curb & Gutter @ Design Point No. 5 for Minor Event

### Gutter

Cross Sl, Sx (ft/ft) = 0.020  
Cross Sl, Sw (ft/ft) = 0.100  
Gutter Width (ft) = 2.00  
Invert Elev (ft) = 100.00  
Slope (%) = 7.00  
N-Value = 0.015

### Highlighted

Depth (ft) = 0.18  
Q (cfs) = 1.000  
Area (sqft) = 0.16  
Velocity (ft/s) = 6.17  
Wetted Perim (ft) = 1.99  
Crit Depth, Yc (ft) = 0.30  
Spread Width (ft) = 1.80  
EGL (ft) = 0.77

### Calculations

Compute by: Known Q  
Known Q (cfs) = 1.00

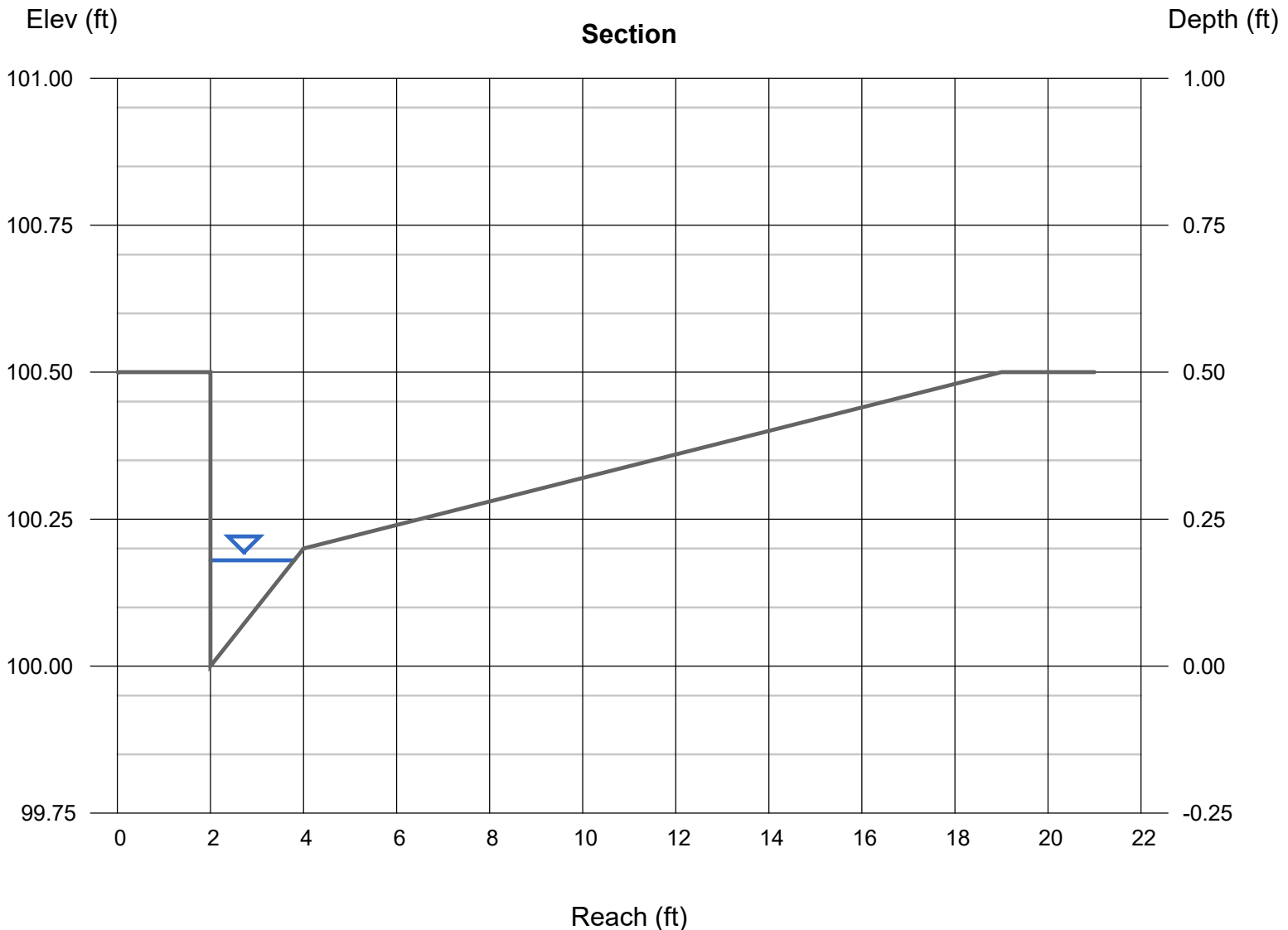

# Channel Report

## Curb & Gutter @ Design Point No. 5 for Major Event

### Gutter

Cross Sl, Sx (ft/ft) = 0.020  
Cross Sl, Sw (ft/ft) = 0.100  
Gutter Width (ft) = 2.00  
Invert Elev (ft) = 100.00  
Slope (%) = 7.00  
N-Value = 0.015

### Highlighted

Depth (ft) = 0.29  
Q (cfs) = 4.140  
Area (sqft) = 0.57  
Velocity (ft/s) = 7.27  
Wetted Perim (ft) = 6.70  
Crit Depth, Yc (ft) = 0.43  
Spread Width (ft) = 6.40  
EGL (ft) = 1.11

### Calculations

Compute by: Known Q  
Known Q (cfs) = 4.14

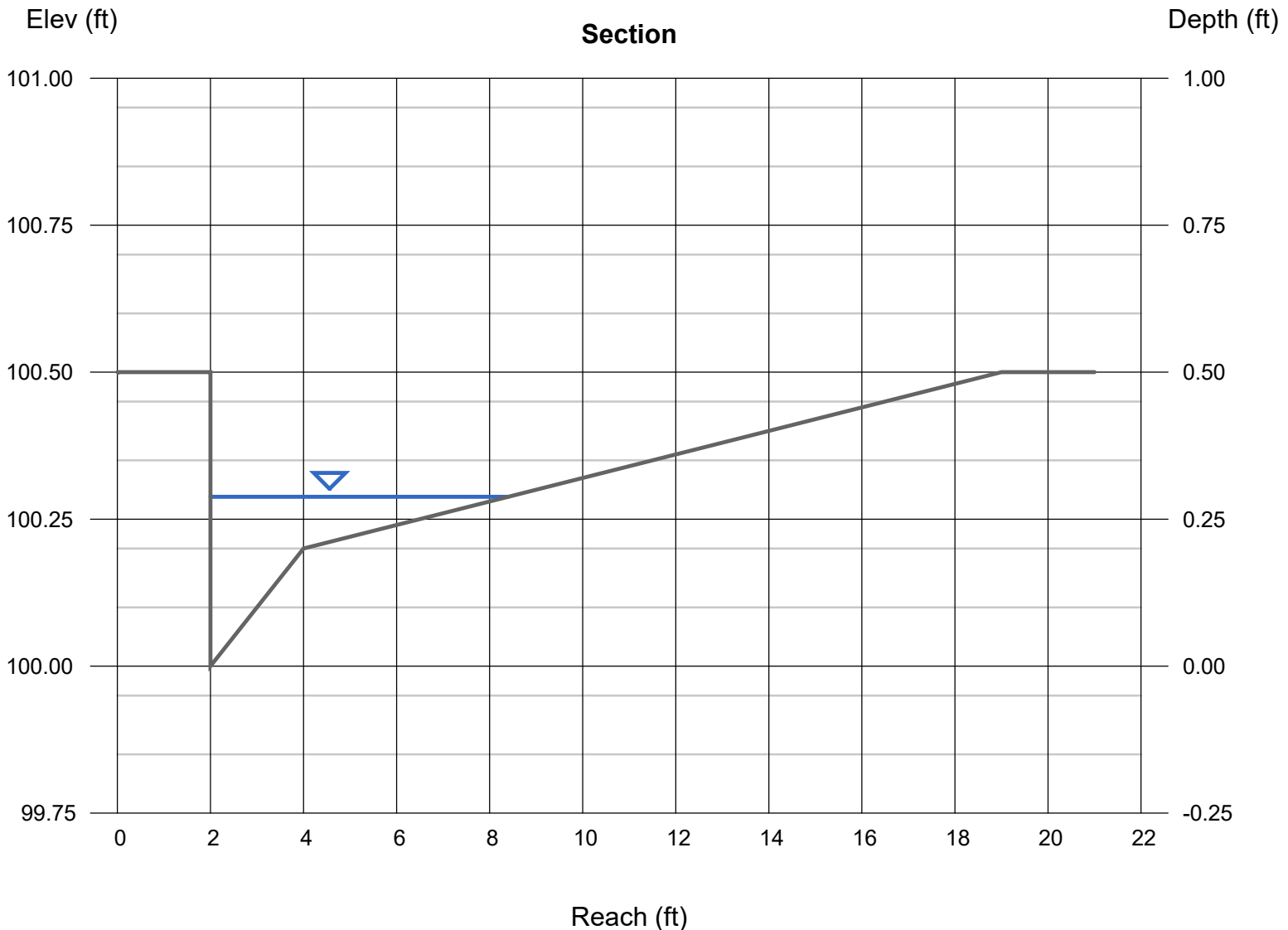

## H. Culvert Calculations

# Culvert Report

## 18-inch Access Culvert Major Event

Invert Elev Dn (ft)	= 6763.60
Pipe Length (ft)	= 47.00
Slope (%)	= 1.91
Invert Elev Up (ft)	= 6764.50
Rise (in)	= 18.0
Shape	= Circular
Span (in)	= 18.0
No. Barrels	= 1
n-Value	= 0.025
Culvert Type	= Circular Culvert
Culvert Entrance	= Smooth tapered inlet throat
Coeff. K,M,c,Y,k	= 0.534, 0.555, 0.0196, 0.9, 0.2

<b>Embankment</b>	
Top Elevation (ft)	= 6768.00
Top Width (ft)	= 26.00
Crest Width (ft)	= 10.00

<b>Calculations</b>	
Qmin (cfs)	= 0.00
Qmax (cfs)	= 5.81
Tailwater Elev (ft)	= Normal

<b>Highlighted</b>	
Qtotal (cfs)	= 5.81
Qpipe (cfs)	= 5.81
Qovertop (cfs)	= 0.00
Veloc Dn (ft/s)	= 4.70
Veloc Up (ft/s)	= 5.05
HGL Dn (ft)	= 6764.59
HGL Up (ft)	= 6765.43
Hw Elev (ft)	= 6765.89
Hw/D (ft)	= 0.92
Flow Regime	= Inlet Control

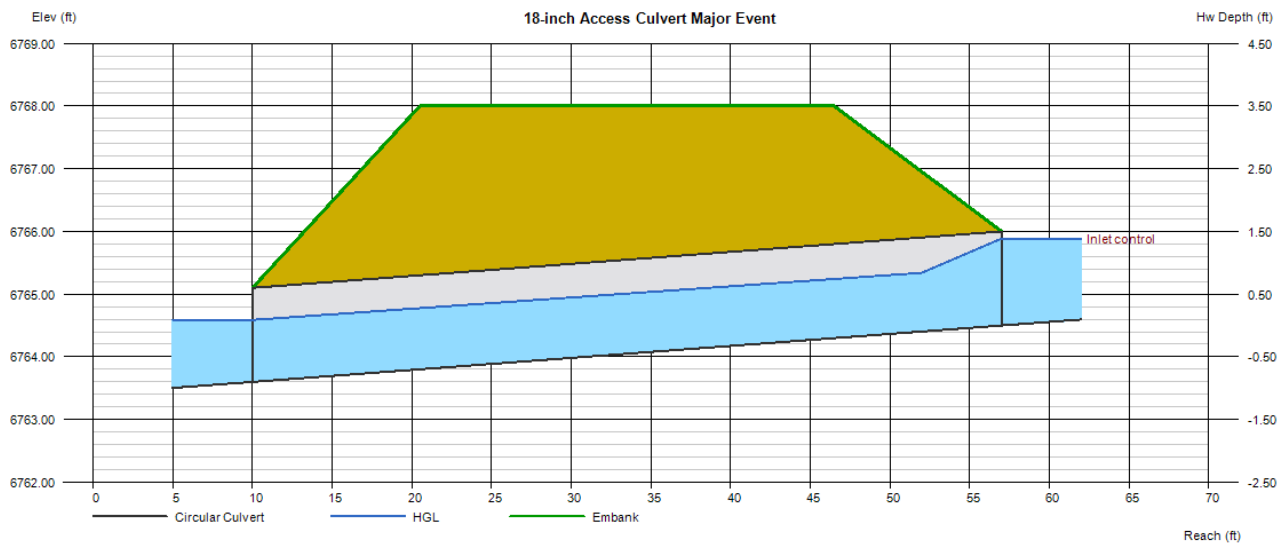

# Culvert Report

## 18-inch Access Culvert Minor Event

Invert Elev Dn (ft)	= 6763.60
Pipe Length (ft)	= 47.00
Slope (%)	= 1.91
Invert Elev Up (ft)	= 6764.50
Rise (in)	= 18.0
Shape	= Circular
Span (in)	= 18.0
No. Barrels	= 1
n-Value	= 0.025
Culvert Type	= Circular Culvert
Culvert Entrance	= Smooth tapered inlet throat
Coeff. K,M,c,Y,k	= 0.534, 0.555, 0.0196, 0.9, 0.2

<b>Embankment</b>	
Top Elevation (ft)	= 6768.00
Top Width (ft)	= 26.00
Crest Width (ft)	= 10.00

<b>Calculations</b>	
Qmin (cfs)	= 0.00
Qmax (cfs)	= 1.32
Tailwater Elev (ft)	= Normal

<b>Highlighted</b>	
Qtotal (cfs)	= 1.32
Qpipe (cfs)	= 1.32
Qovertop (cfs)	= 0.00
Veloc Dn (ft/s)	= 3.15
Veloc Up (ft/s)	= 3.15
HGL Dn (ft)	= 6764.03
HGL Up (ft)	= 6764.93
Hw Elev (ft)	= 6765.11
Hw/D (ft)	= 0.41
Flow Regime	= Inlet Control

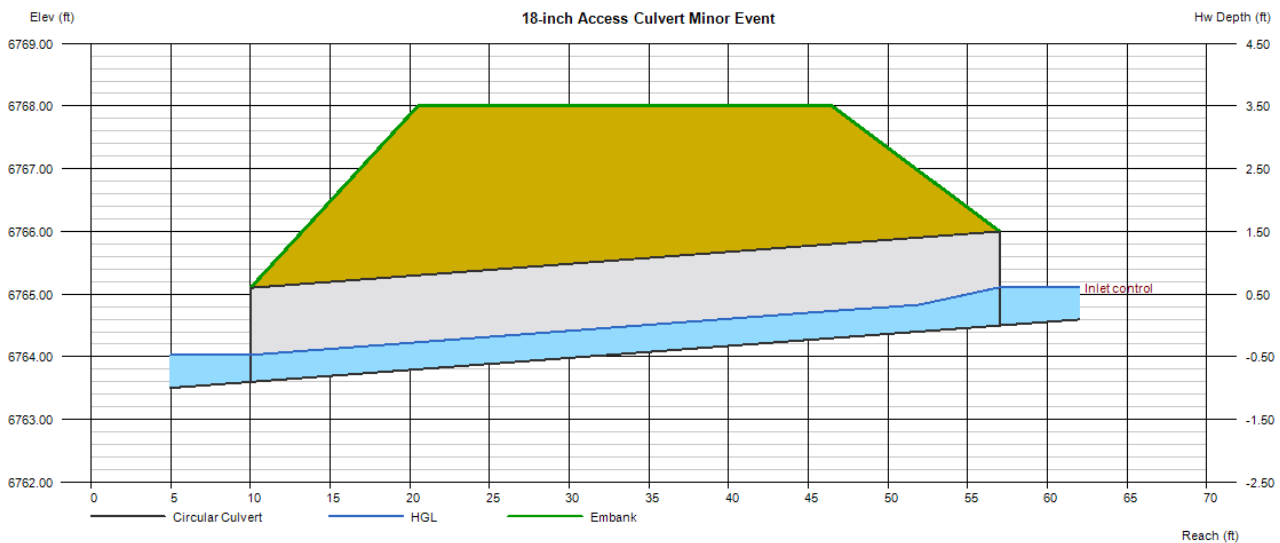

# Culvert Report

## 18-inch Culvert Crossing @ Design Point No. 7 for Major Event

Invert Elev Dn (ft)	= 6797.00
Pipe Length (ft)	= 45.00
Slope (%)	= 4.44
Invert Elev Up (ft)	= 6799.00
Rise (in)	= 18.0
Shape	= Circular
Span (in)	= 18.0
No. Barrels	= 1
n-Value	= 0.013
Culvert Type	= Circular Culvert
Culvert Entrance	= Smooth tapered inlet throat
Coeff. K,M,c,Y,k	= 0.534, 0.555, 0.0196, 0.9, 0.2

<b>Embankment</b>	
Top Elevation (ft)	= 6801.00
Top Width (ft)	= 30.00
Crest Width (ft)	= 5.00

<b>Calculations</b>	
Qmin (cfs)	= 0.00
Qmax (cfs)	= 12.10
Tailwater Elev (ft)	= Normal

<b>Highlighted</b>	
Qtotal (cfs)	= 12.10
Qpipe (cfs)	= 11.42
Qovertop (cfs)	= 0.68
Veloc Dn (ft/s)	= 11.54
Veloc Up (ft/s)	= 7.07
HGL Dn (ft)	= 6797.82
HGL Up (ft)	= 6800.29
Hw Elev (ft)	= 6801.14
Hw/D (ft)	= 1.42
Flow Regime	= Inlet Control

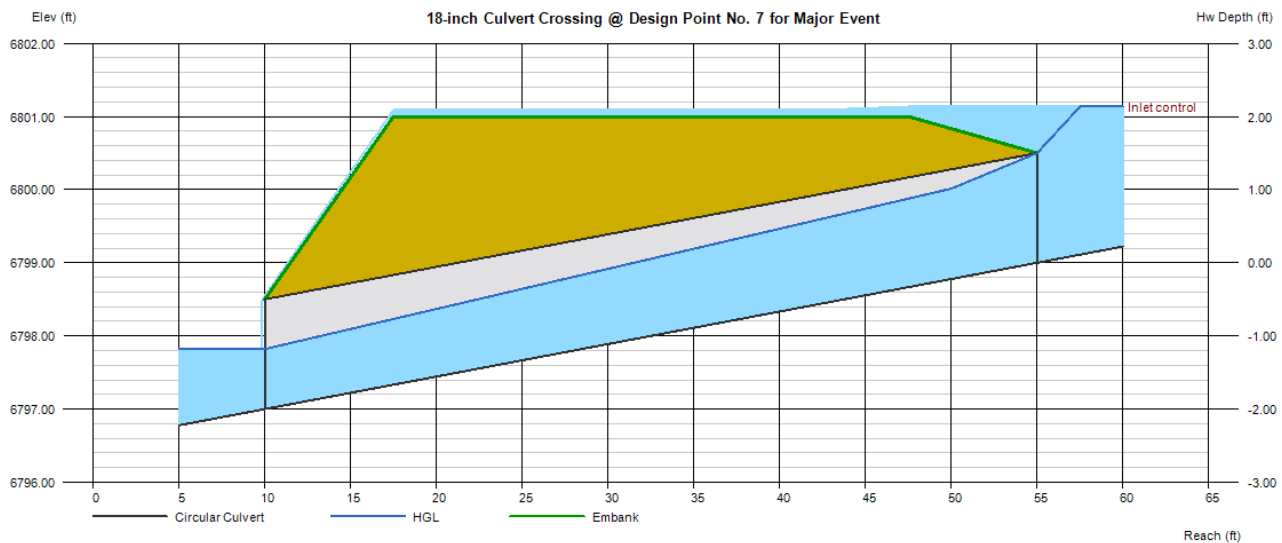

# Culvert Report

## 18-inch Culvert Crossing @ Design Point No. 7 for Minor Event

Invert Elev Dn (ft)	= 6797.00
Pipe Length (ft)	= 45.00
Slope (%)	= 4.44
Invert Elev Up (ft)	= 6799.00
Rise (in)	= 18.0
Shape	= Circular
Span (in)	= 18.0
No. Barrels	= 1
n-Value	= 0.013
Culvert Type	= Circular Culvert
Culvert Entrance	= Smooth tapered inlet throat
Coeff. K,M,c,Y,k	= 0.534, 0.555, 0.0196, 0.9, 0.2

<b>Embankment</b>	
Top Elevation (ft)	= 6801.00
Top Width (ft)	= 30.00
Crest Width (ft)	= 5.00

<b>Calculations</b>	
Qmin (cfs)	= 0.00
Qmax (cfs)	= 3.30
Tailwater Elev (ft)	= Normal

<b>Highlighted</b>	
Qtotal (cfs)	= 3.30
Qpipe (cfs)	= 3.30
Qovertop (cfs)	= 0.00
Veloc Dn (ft/s)	= 8.83
Veloc Up (ft/s)	= 4.14
HGL Dn (ft)	= 6797.40
HGL Up (ft)	= 6799.69
Hw Elev (ft)	= 6800.01
Hw/D (ft)	= 0.67
Flow Regime	= Inlet Control

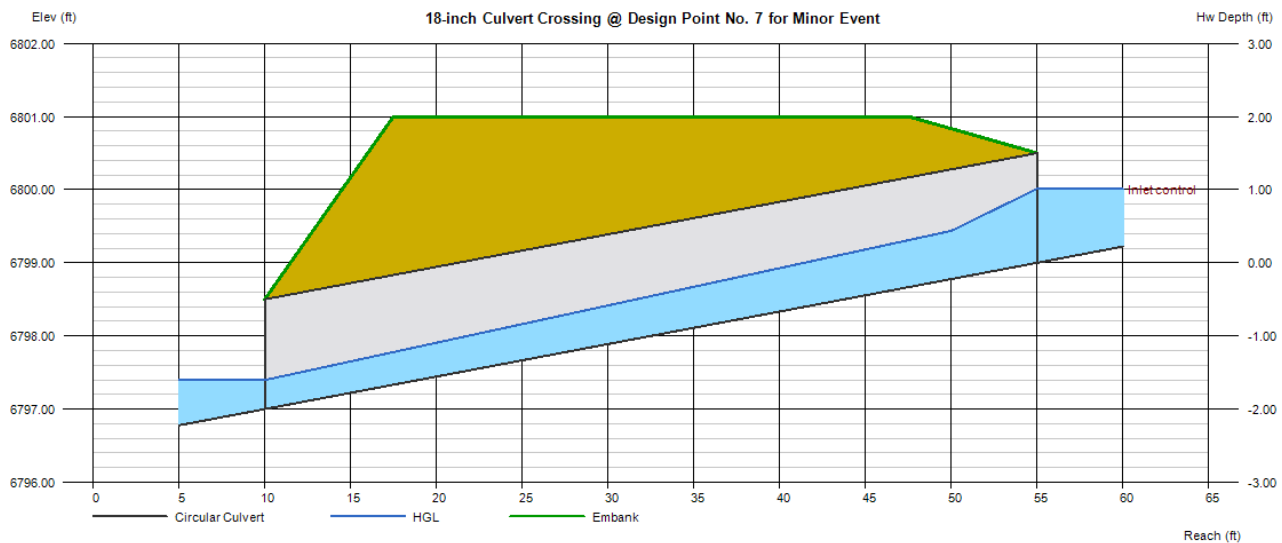



# Culvert Report

## EB3 BYPASS CULVERT Minor Event

Invert Elev Dn (ft)	= 6800.00
Pipe Length (ft)	= 180.00
Slope (%)	= 5.00
Invert Elev Up (ft)	= 6809.00
Rise (in)	= 24.0
Shape	= Circular
Span (in)	= 24.0
No. Barrels	= 1
n-Value	= 0.013
Culvert Type	= Circular Corrugate Metal Pipe
Culvert Entrance	= Headwall
Coeff. K,M,c,Y,k	= 0.0078, 2, 0.0379, 0.69, 0.5

### Embankment

Top Elevation (ft)	= 6812.00
Top Width (ft)	= 170.00
Crest Width (ft)	= 10.00

### Calculations

Qmin (cfs)	= 0.00
Qmax (cfs)	= 2.86
Tailwater Elev (ft)	= (dc+D)/2

### Highlighted

Qtotal (cfs)	= 2.86
Qpipe (cfs)	= 2.86
Qovertop (cfs)	= 0.00
Veloc Dn (ft/s)	= 1.33
Veloc Up (ft/s)	= 3.70
HGL Dn (ft)	= 6801.29
HGL Up (ft)	= 6809.59
Hw Elev (ft)	= 6809.76
Hw/D (ft)	= 0.38
Flow Regime	= Inlet Control

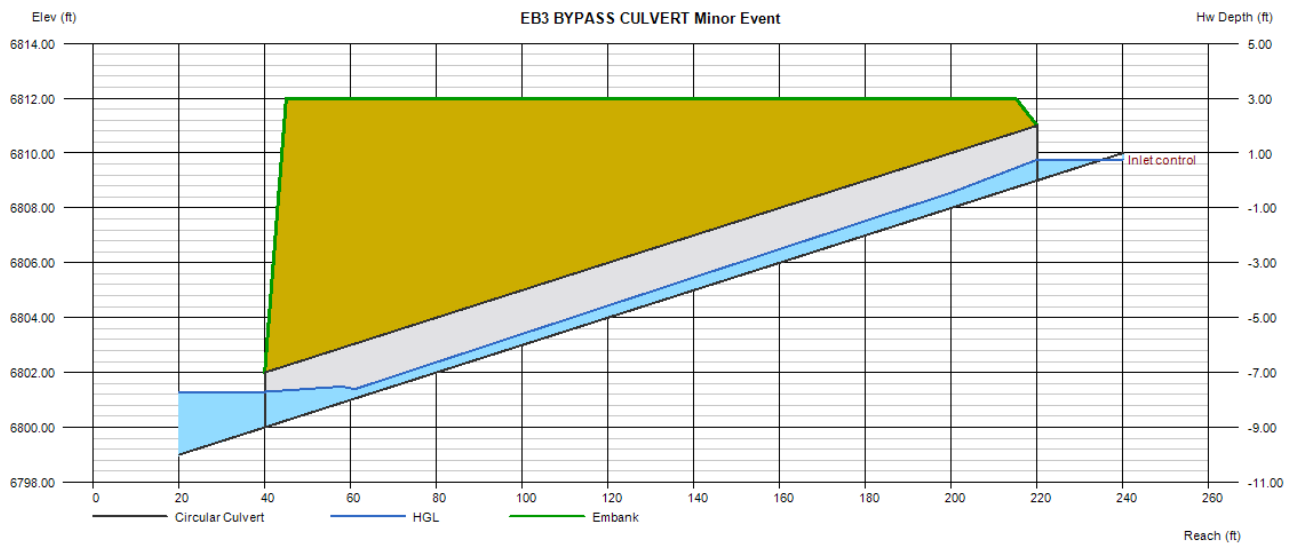

# Culvert Report

## Gloria Gossard Dual 30-inch Culvert Crossing - Surcharged Capacity

Invert Elev Dn (ft)	= 6749.70
Pipe Length (ft)	= 100.00
Slope (%)	= 0.70
Invert Elev Up (ft)	= 6750.40
Rise (in)	= 30.0
Shape	= Circular
Span (in)	= 30.0
No. Barrels	= 2
n-Value	= 0.024
Culvert Type	= Circular Corrugate Metal Pipe
Culvert Entrance	= Mitered to slope (C)
Coeff. K,M,c,Y,k	= 0.021, 1.33, 0.0463, 0.75, 0.7

<b>Embankment</b>	
Top Elevation (ft)	= 6759.00
Top Width (ft)	= 70.00
Crest Width (ft)	= 10.00

<b>Calculations</b>	
Qmin (cfs)	= 30.00
Qmax (cfs)	= 100.00
Tailwater Elev (ft)	= Normal

<b>Highlighted</b>	
Qtotal (cfs)	= 40.00
Qpipe (cfs)	= 40.00
Qovertop (cfs)	= 0.00
Veloc Dn (ft/s)	= 4.08
Veloc Up (ft/s)	= 4.07
HGL Dn (ft)	= 6752.20
HGL Up (ft)	= 6753.01
Hw Elev (ft)	= 6753.45
Hw/D (ft)	= 1.22
Flow Regime	= Outlet Control

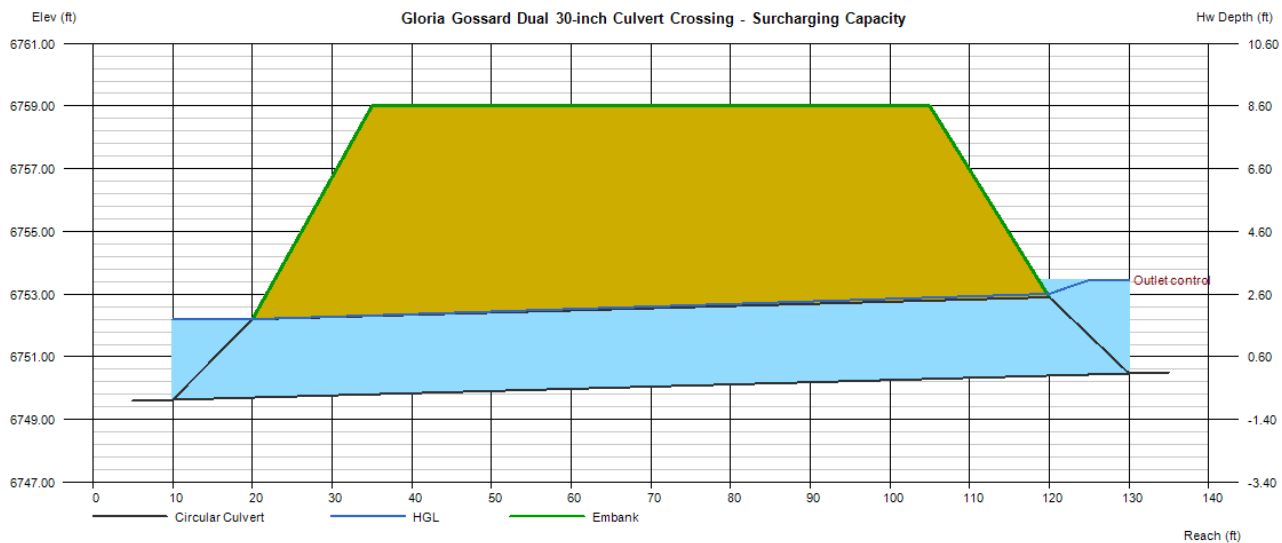

# Culvert Report

## Gloria Gossard Dual 30-inch Culvert Crossing - Overtopping Condition

Invert Elev Dn (ft)	= 6749.70
Pipe Length (ft)	= 100.00
Slope (%)	= 0.70
Invert Elev Up (ft)	= 6750.40
Rise (in)	= 30.0
Shape	= Circular
Span (in)	= 30.0
No. Barrels	= 2
n-Value	= 0.024
Culvert Type	= Circular Corrugate Metal Pipe
Culvert Entrance	= Mitered to slope (C)
Coeff. K,M,c,Y,k	= 0.021, 1.33, 0.0463, 0.75, 0.7

<b>Embankment</b>	
Top Elevation (ft)	= 6759.00
Top Width (ft)	= 70.00
Crest Width (ft)	= 10.00

<b>Calculations</b>	
Qmin (cfs)	= 30.00
Qmax (cfs)	= 100.00
Tailwater Elev (ft)	= Normal
<b>Highlighted</b>	
Qtotal (cfs)	= 95.00
Qpipe (cfs)	= 94.98
Qovertop (cfs)	= 0.02
Veloc Dn (ft/s)	= 9.68
Veloc Up (ft/s)	= 9.68
HGL Dn (ft)	= 6752.20
HGL Up (ft)	= 6756.77
Hw Elev (ft)	= 6759.25
Hw/D (ft)	= 3.54
Flow Regime	= Outlet Control



I. Inlet Calculations and Sizing

# Inlet Report

## Nyloplast Curb Inlet @ Design Point No. 9 for Minor Event

### Combination Inlet

Location	= On grade
Curb Length (ft)	= 2.00
Throat Height (in)	= 6.00
Grate Area (sqft)	= -0-
Grate Width (ft)	= 2.00
Grate Length (ft)	= 2.00

### Gutter

Slope, Sw (ft/ft)	= 0.080
Slope, Sx (ft/ft)	= 0.020
Local Depr (in)	= 1.00
Gutter Width (ft)	= 2.00
Gutter Slope (%)	= 7.00
Gutter n-value	= 0.013

### Calculations

Compute by:	Known Q
Q (cfs)	= 0.40

### Highlighted

Q Total (cfs)	= 0.40
Q Capt (cfs)	= 0.40
Q Bypass (cfs)	= -0-
Depth at Inlet (in)	= 2.33
Efficiency (%)	= 100
Gutter Spread (ft)	= 1.38
Gutter Vel (ft/s)	= 5.24
Bypass Spread (ft)	= -0-
Bypass Depth (in)	= -0-

All dimensions in feet

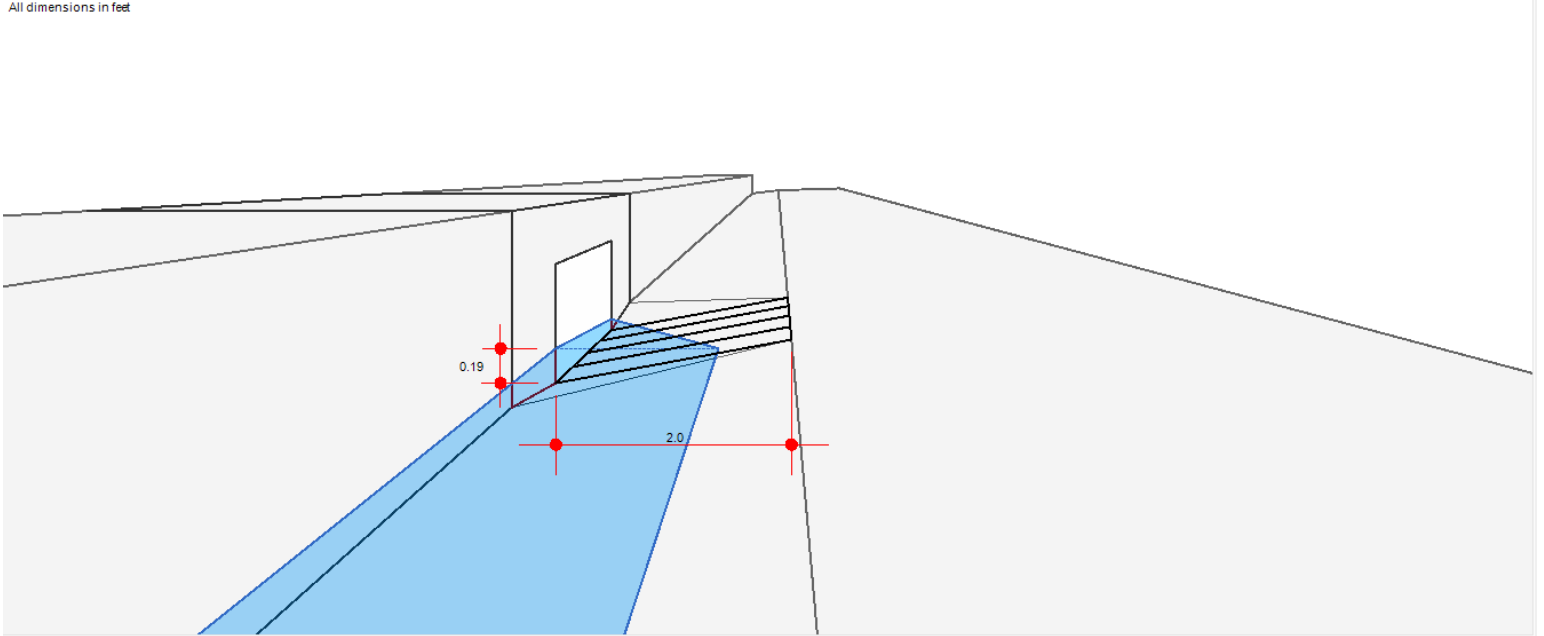

# Inlet Report

## Nyloplast Curb Inlet @ Design Point No. 9 for Major event

### Combination Inlet

Location	= On grade
Curb Length (ft)	= 2.00
Throat Height (in)	= 6.00
Grate Area (sqft)	= -0-
Grate Width (ft)	= 2.00
Grate Length (ft)	= 2.00

### Gutter

Slope, Sw (ft/ft)	= 0.080
Slope, Sx (ft/ft)	= 0.020
Local Depr (in)	= 1.00
Gutter Width (ft)	= 2.00
Gutter Slope (%)	= 7.00
Gutter n-value	= 0.013

### Calculations

Compute by:	Known Q
Q (cfs)	= 1.20

### Highlighted

Q Total (cfs)	= 1.20
Q Capt (cfs)	= 1.20
Q Bypass (cfs)	= -0-
Depth at Inlet (in)	= 3.00
Efficiency (%)	= 100
Gutter Spread (ft)	= 2.34
Gutter Vel (ft/s)	= 6.87
Bypass Spread (ft)	= -0-
Bypass Depth (in)	= -0-

All dimensions in feet

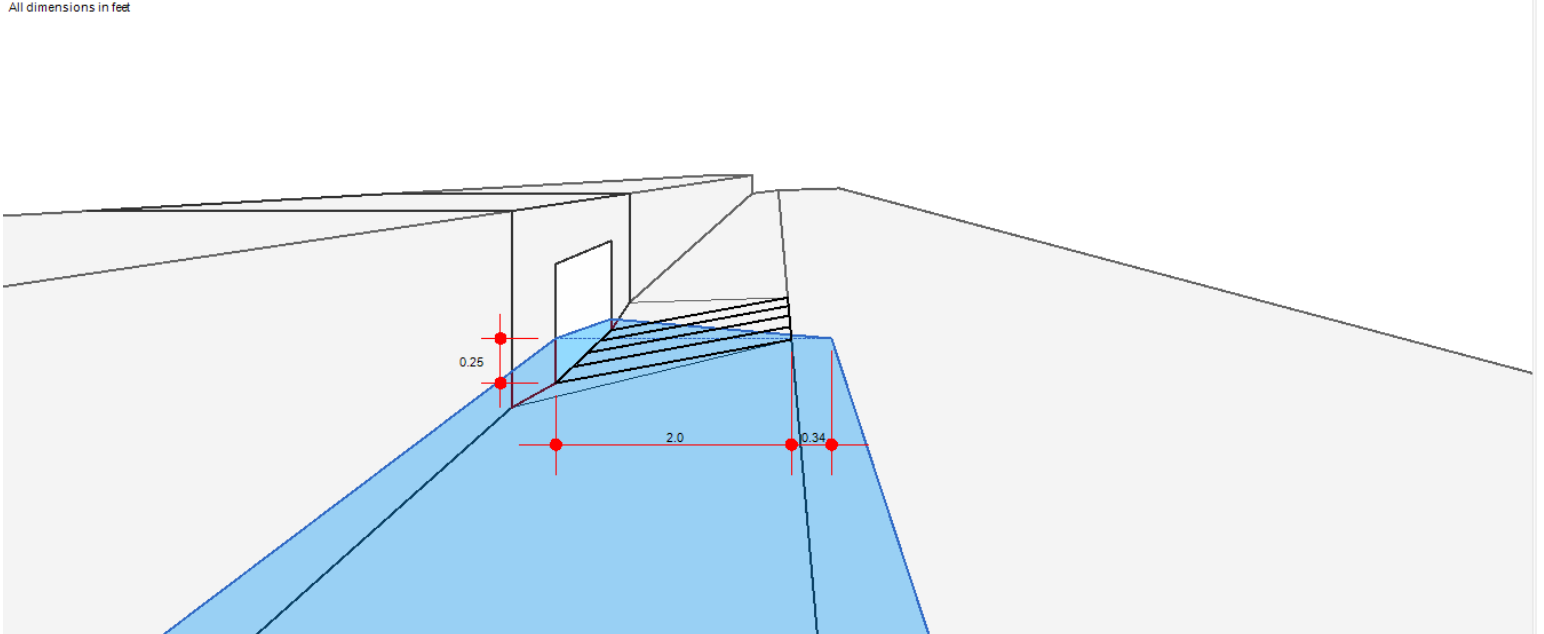

# Inlet Report

## Nyloplast Curb Inlet @ Design Point No. 10 for Minor Event

### Combination Inlet

Location	= On grade
Curb Length (ft)	= 2.00
Throat Height (in)	= 6.00
Grate Area (sqft)	= -0-
Grate Width (ft)	= 2.00
Grate Length (ft)	= 2.00

### Gutter

Slope, Sw (ft/ft)	= 0.080
Slope, Sx (ft/ft)	= 0.020
Local Depr (in)	= 1.00
Gutter Width (ft)	= 2.00
Gutter Slope (%)	= 7.00
Gutter n-value	= 0.013

### Calculations

Compute by:	Known Q
Q (cfs)	= 0.80

### Highlighted

Q Total (cfs)	= 0.80
Q Capt (cfs)	= 0.80
Q Bypass (cfs)	= -0-
Depth at Inlet (in)	= 2.72
Efficiency (%)	= 100
Gutter Spread (ft)	= 1.79
Gutter Vel (ft/s)	= 6.23
Bypass Spread (ft)	= -0-
Bypass Depth (in)	= -0-

All dimensions in feet

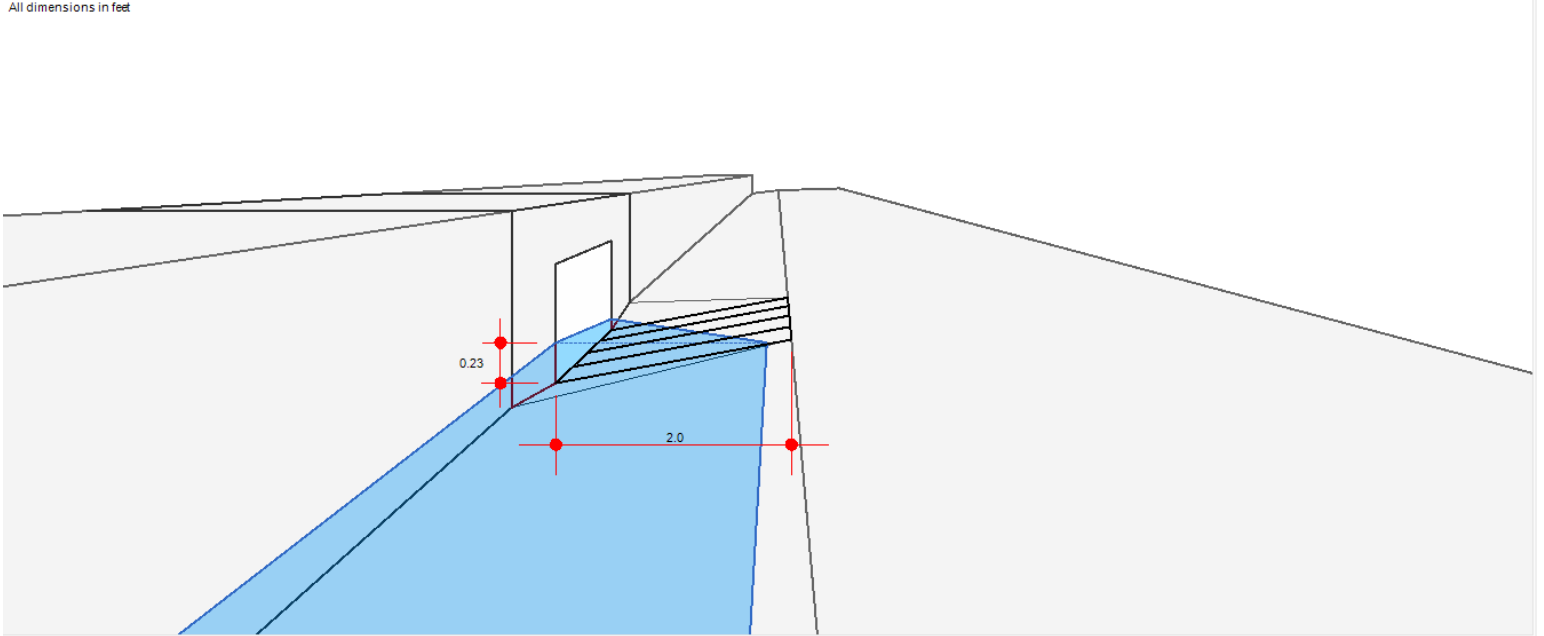

# Inlet Report

## Nyloplast Curb Inlet @ Design Point No. 10 for Major Event

### Combination Inlet

Location	= On grade
Curb Length (ft)	= 2.00
Throat Height (in)	= 6.00
Grate Area (sqft)	= -0-
Grate Width (ft)	= 2.00
Grate Length (ft)	= 2.00

### Gutter

Slope, Sw (ft/ft)	= 0.080
Slope, Sx (ft/ft)	= 0.020
Local Depr (in)	= 1.00
Gutter Width (ft)	= 2.00
Gutter Slope (%)	= 7.00
Gutter n-value	= 0.013

### Calculations

Compute by:	Known Q
Q (cfs)	= 2.20

### Highlighted

Q Total (cfs)	= 2.20
Q Capt (cfs)	= 2.06
Q Bypass (cfs)	= 0.14
Depth at Inlet (in)	= 3.46
Efficiency (%)	= 93
Gutter Spread (ft)	= 4.27
Gutter Vel (ft/s)	= 7.29
Bypass Spread (ft)	= 0.94
Bypass Depth (in)	= 0.91

All dimensions in feet

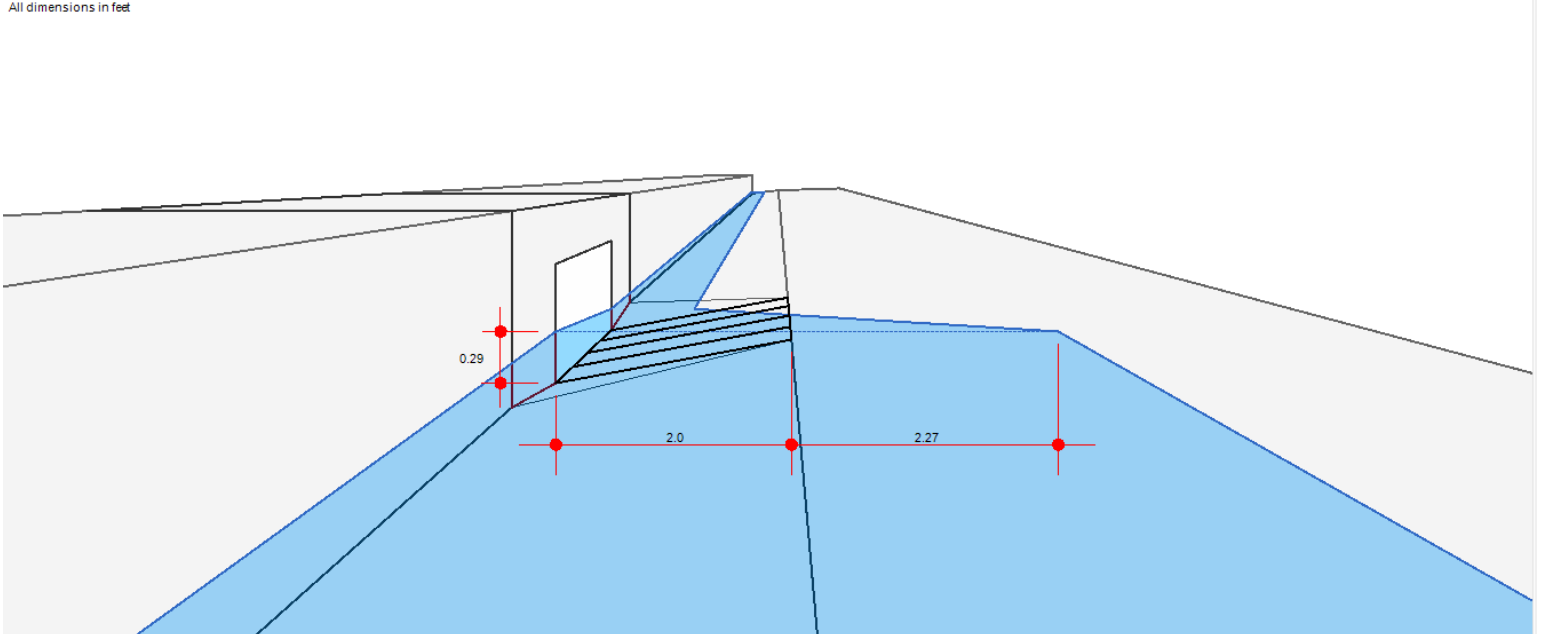

J. Channel Calculations

# Channel Report

## Design Point No. 4 Drainage Ditch for Major Event

### Triangular

Side Slopes (z:1) = 2.00, 2.00  
Total Depth (ft) = 2.00

Invert Elev (ft) = 100.00  
Slope (%) = 7.00  
N-Value = 0.040

### Calculations

Compute by: Known Q  
Known Q (cfs) = 13.00

### Highlighted

Depth (ft) = 1.05  
Q (cfs) = 13.00  
Area (sqft) = 2.20  
Velocity (ft/s) = 5.90  
Wetted Perim (ft) = 4.70  
Crit Depth, Yc (ft) = 1.22  
Top Width (ft) = 4.20  
EGL (ft) = 1.59

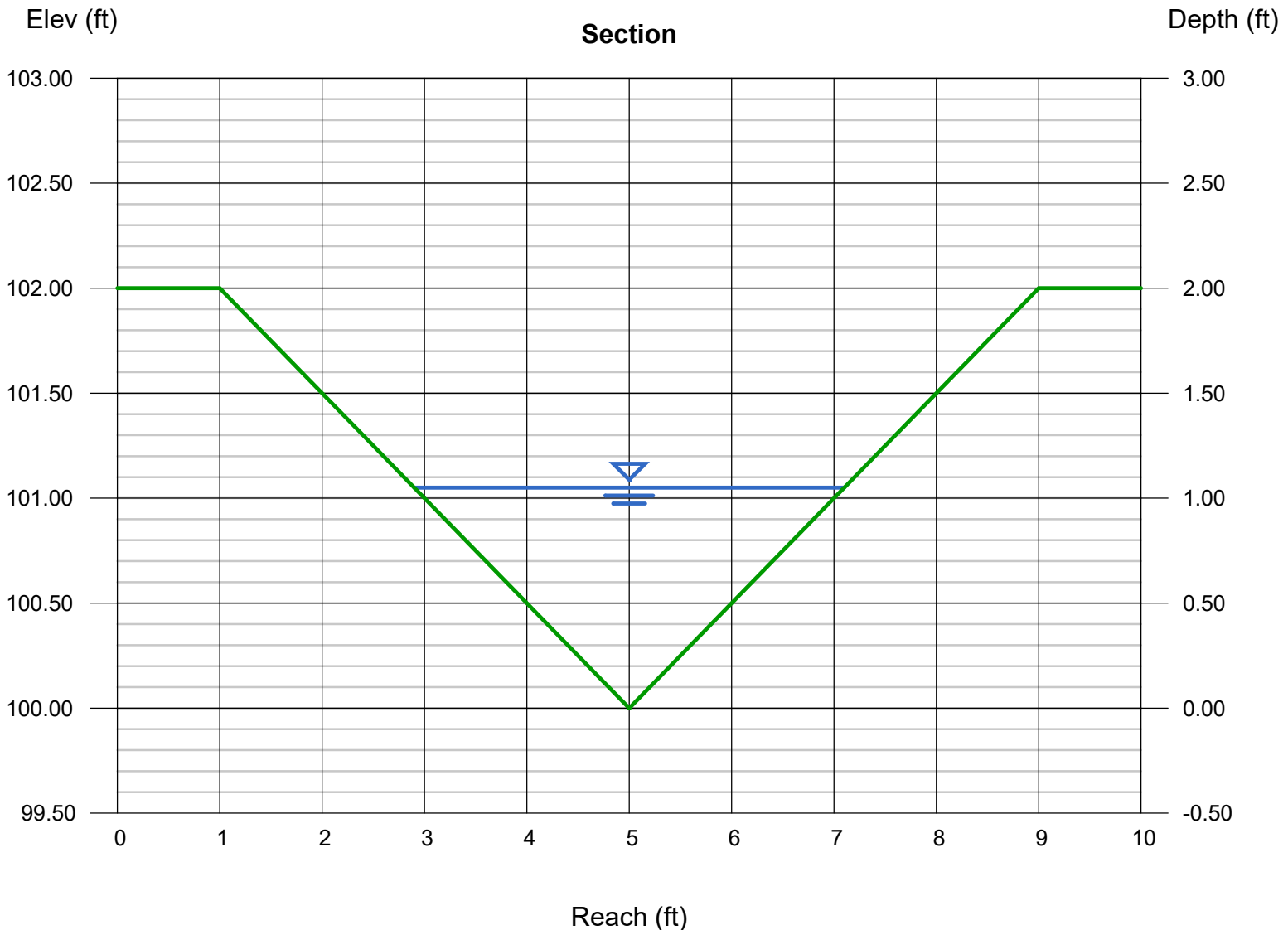

# Channel Report

## Design Point No. 6 - Valley Pan for Minor Event

### User-defined

Invert Elev (ft) = 100.00  
Slope (%) = 2.00  
N-Value = 0.015

### Highlighted

Depth (ft) = 0.14  
Q (cfs) = 0.450  
Area (sqft) = 0.23  
Velocity (ft/s) = 1.96  
Wetted Perim (ft) = 4.01  
Crit Depth, Yc (ft) = 0.17  
Top Width (ft) = 4.00  
EGL (ft) = 0.20

### Calculations

Compute by: Known Q  
Known Q (cfs) = 0.45

### (Sta, El, n)-(Sta, El, n)...

(0.00, 100.33)-(10.00, 100.13, 0.015)-(11.50, 100.00, 0.015)-(13.00, 100.13, 0.015)-(23.00, 100.33, 0.015)

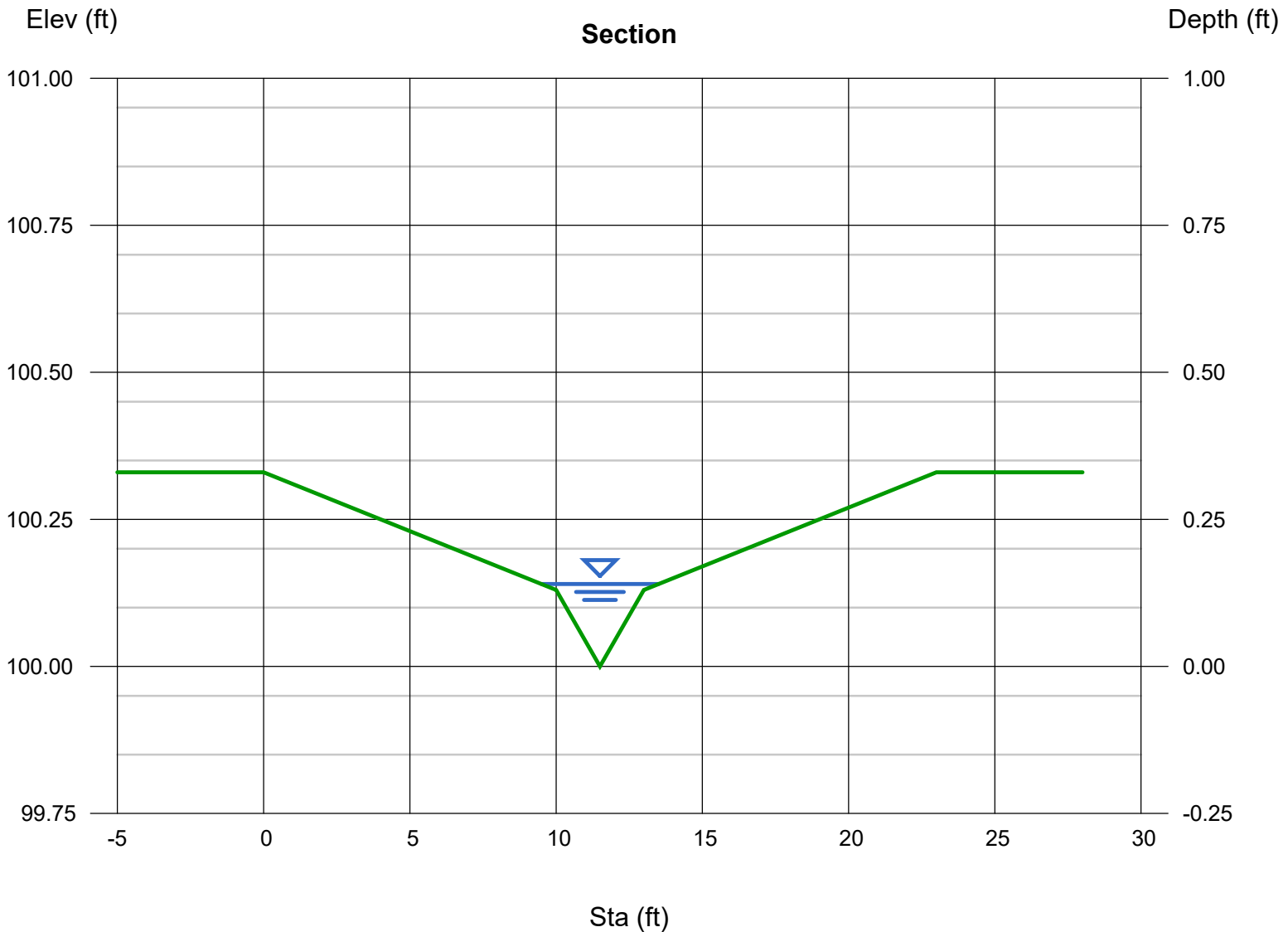

# Channel Report

## Design Point No. 6 - Valley Pan for Major Event

### User-defined

Invert Elev (ft) = 100.00  
Slope (%) = 2.00  
N-Value = 0.015

### Highlighted

Depth (ft) = 0.20  
Q (cfs) = 1.300  
Area (sqft) = 0.65  
Velocity (ft/s) = 2.00  
Wetted Perim (ft) = 10.01  
Crit Depth, Yc (ft) = 0.22  
Top Width (ft) = 10.00  
EGL (ft) = 0.26

### Calculations

Compute by: Known Q  
Known Q (cfs) = 1.30

### (Sta, El, n)-(Sta, El, n)...

(0.00, 100.33)-(10.00, 100.13, 0.015)-(11.50, 100.00, 0.015)-(13.00, 100.13, 0.015)-(23.00, 100.33, 0.015)

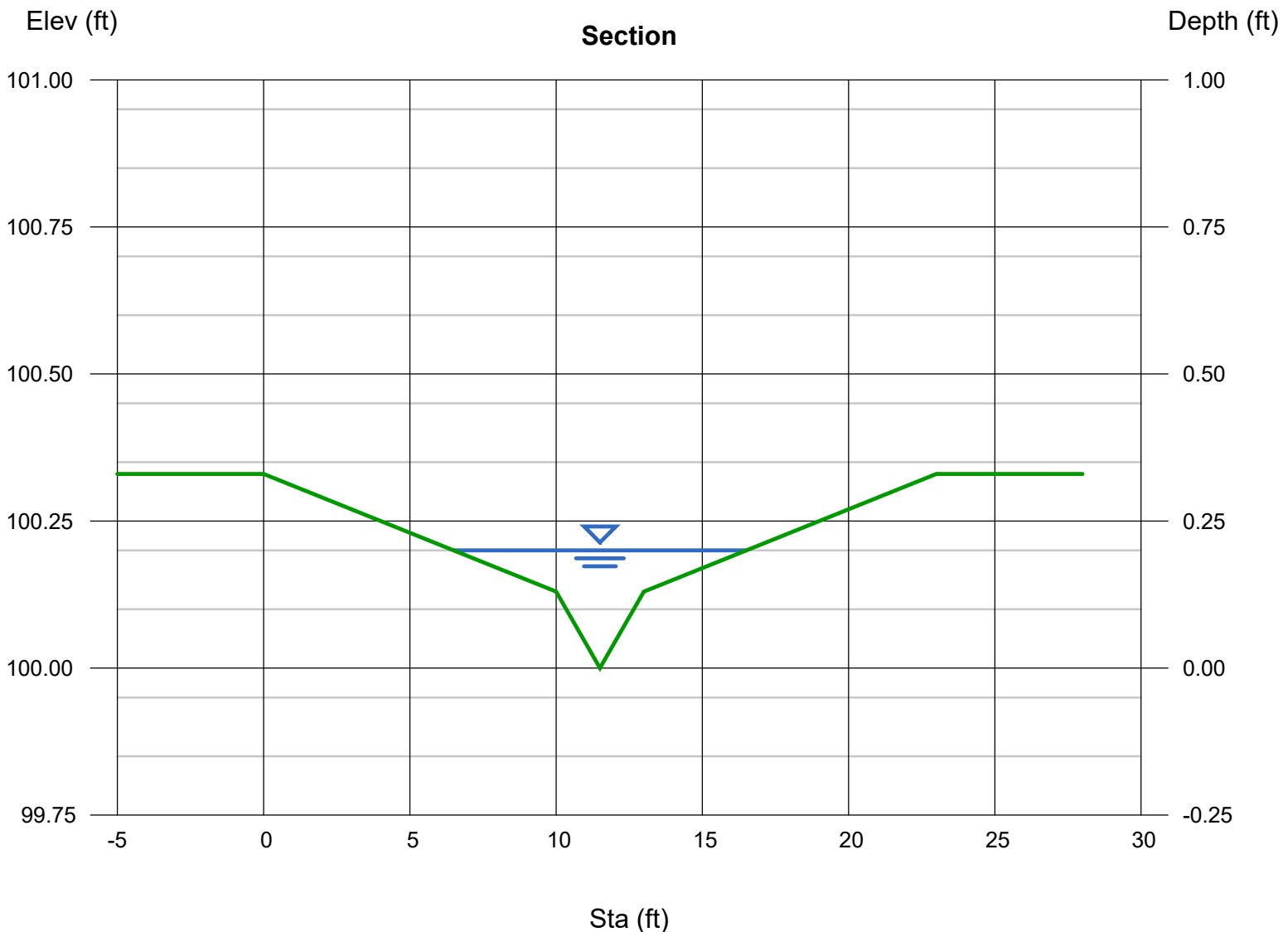

K. Pipe Flow Velocity Table

Pipe Outfall	Pipe Outfall Velocity (ft/sec)	
	Minor Event	Major Event
Access Crossing @ Design Pt. No. 8	3.15	4.7
Culvert Crossing @ Design Pt. No. 7	8.83	11.54
EB3 Bypass Pipe @ Design Pt. No. 3/2	1.33	6.58
(See following sheets for veocities for the private stormwater network leading to PLDF)		-

# Hydraulic Grade Line Computations

1.25 Yr Design Event flows for Copper Ridge Storm Sewers (leading to PLDF)

Line	Size (in)	Q (cfs)	Downstream								Len (ft)	Upstream								Check		JL coeff (K)	Minor loss (ft)	
			Invert elev (ft)	HGL elev (ft)	Depth (ft)	Area (sqft)	Vel (ft/s)	Vel head (ft)	EGL elev (ft)	Sf (%)		Invert elev (ft)	HGL elev (ft)	Depth (ft)	Area (sqft)	Vel (ft/s)	Vel head (ft)	EGL elev (ft)	Sf (%)	Ave Sf (%)	Enrgy loss (ft)			
1	24	0.00	6775.00	6775.53	0.00	0.00	3.50	0.00	6775.53	0.000	31.000	6777.80	6778.33	j	0.00**	0.00	3.50	0.00	6778.33	0.000	0.000	0.000	0.50	n/a
2	12	0.00	6780.00	6780.20	0.00	0.00	9.18	0.00	6780.20	0.000	32.000	6783.00	6783.42	j	0.00**	0.00	3.21	0.00	6783.42	0.000	0.000	0.000	1.50	n/a
3	12	0.00	6783.10	6783.42	0.00	0.00	1.65	0.00	6783.42	0.000	45.779	6787.50	6787.75	j	0.00**	0.00	2.38	0.00	6787.75	0.000	0.000	0.000	1.09	n/a
4	12	0.00	6787.60	6787.75	0.00	0.00	2.08	0.00	6787.75	0.000	158.083	6793.00	6793.16	j	0.00**	0.00	1.88	0.00	6793.16	0.000	0.000	0.000	1.00	n/a
5	12	0.00	6783.60	6783.77	0.00	0.00	7.13	0.00	6783.77	0.000	61.243	6787.90	6788.23	j	0.00**	0.00	2.76	0.00	6788.23	0.000	0.000	0.000	0.50	n/a
6	12	0.00	6787.75	6788.23	0.00	0.00	1.42	0.00	6788.23	0.000	86.695	6793.25	6793.55	j	0.00**	0.00	2.64	0.00	6793.55	0.000	0.000	0.000	1.38	n/a
7	12	0.00	6793.35	6793.55	0.00	0.00	3.61	0.00	6793.55	0.000	39.867	6795.95	6796.21	j	0.00**	0.00	2.45	0.00	6796.21	0.000	0.000	0.000	0.86	n/a
8	12	0.00	6795.80	6796.21	0.00	0.00	0.36	0.00	6796.21	0.000	88.000	6801.50	6801.64	j	0.00**	0.00	1.73	0.00	6801.64	0.000	0.000	0.000	1.16	n/a
9	12	0.00	6801.60	6801.66	0.00	0.00	4.85	0.00	6801.66	0.000	72.000	6810.40	6810.52	j	0.00**	0.00	1.64	0.00	6810.52	0.000	0.000	0.000	1.09	n/a
10	12	0.00	6810.50	6810.52	0.00	0.00	2.04	0.00	6810.52	0.000	162.000	6821.50	6821.54	j	0.00**	0.00	0.93	0.00	6821.54	0.000	0.000	0.000	1.00	n/a
11	12	0.00	6772.00	6772.31	0.00	0.00	2.67	0.00	6772.31	0.000	32.000	6772.30	6772.60	j	0.00**	0.00	2.67	0.00	6772.60	0.000	0.000	0.000	0.50	n/a
12	12	0.00	6772.45	6772.67	0.00	0.00	3.87	0.00	6772.67	0.000	47.666	6773.15	6773.44	j	0.00**	0.00	2.61	0.00	6773.44	0.000	0.000	0.000	1.00	n/a
13	24	0.00	6803.20	6803.39	0.00	0.00	10.13	0.00	6803.39	0.000	13.951	6804.80	6805.22	j	0.00**	0.00	3.09	0.00	6805.22	0.000	0.000	0.000	1.40	n/a
14	12	0.00	6805.55	6805.68	0.00	0.00	5.41	0.00	6805.68	0.000	39.999	6807.62	6807.86	j	0.00**	0.00	2.34	0.00	6807.86	0.000	0.000	0.000	1.00	n/a
15	18	0.00	6805.30	6805.54	0.00	0.00	6.50	0.00	6805.54	0.000	27.659	6806.30	6806.70	j	0.00**	0.00	3.04	0.00	6806.70	0.000	0.000	0.000	1.73	n/a
16	12	0.00	6806.60	6806.78	0.00	0.00	3.55	0.00	6806.78	0.000	24.813	6807.00	6807.24	j	0.00**	0.00	2.32	0.00	6807.24	0.000	0.000	0.000	1.00	n/a
17	12	0.00	6806.60	6806.80	0.00	0.00	6.50	0.00	6806.80	0.000	188.500	6815.30	6815.66	j	0.00**	0.00	2.91	0.00	6815.66	0.000	0.000	0.000	1.17	n/a
18	12	0.00	6815.30	6815.66	0.00	0.00	0.80	0.00	6815.66	0.000	24.000	6815.70	6815.88	j	0.00**	0.00	2.03	0.00	6815.88	0.000	0.000	0.000	1.00	n/a
19	12	0.00	6815.55	6815.72	0.00	0.00	5.86	0.00	6815.72	0.000	59.792	6818.35	6818.65	j	0.00**	0.00	2.62	0.00	6818.65	0.000	0.000	0.000	0.86	n/a
20	12	0.00	6818.20	6818.65	0.00	0.00	0.95	0.00	6818.65	0.000	24.000	6818.60	6818.83	j	0.00**	0.00	2.30	0.00	6818.83	0.000	0.000	0.000	1.00	n/a
21	12	0.00	6818.20	6818.65	0.00	0.00	0.18	0.00	6818.65	0.000	202.000	6821.65	6821.75	j	0.00**	0.00	1.48	0.00	6821.75	0.000	0.000	0.000	0.50	n/a
22	12	0.00	6821.75	6821.82	0.00	0.00	1.71	0.00	6821.82	0.000	24.000	6822.05	6822.13	j	0.00**	0.00	1.33	0.00	6822.13	0.000	0.000	0.000	1.00	n/a

see HGL/EGL profiles for line no. designation

Project File: CRV\_DESIGN.

Number of lines: 22

Run Date: 12/2/2021

Notes: ; \*\* Critical depth.; j-Line contains hyd. jump ; c = cir e = ellip b = box

# Hydraulic Grade Line Computations

Minor Event flows for Copper Ridge Storm Sewers (leading to PLDF)

Line	Size (in)	Q (cfs)	Downstream								Len (ft)	Upstream								Check		JL coeff (K)	Minor loss (ft)
			Invert elev (ft)	HGL elev (ft)	Depth (ft)	Area (sqft)	Vel (ft/s)	Vel head (ft)	EGL elev (ft)	Sf (%)		Invert elev (ft)	HGL elev (ft)	Depth (ft)	Area (sqft)	Vel (ft/s)	Vel head (ft)	EGL elev (ft)	Sf (%)	Ave Sf (%)	Enrgy loss (ft)		
1	12	5.89	6776.00	6776.98	0.98	0.77	7.55	0.91	6777.88	0.000	31.000	6778.80	6779.75 j	0.95**	0.77	7.63	0.91	6780.66	0.000	0.000	n/a	0.50	0.45
2	12	2.51	6780.00	6780.31	0.31*	0.21	11.94	0.30	6780.62	0.000	32.000	6783.00	6783.68	0.68**	0.57	4.43	0.30	6783.98	0.000	0.000	n/a	1.50	0.46
3	12	0.91	6783.10	6783.68	0.58	0.29	1.93	0.15	6783.83	0.000	45.779	6787.50	6787.90 j	0.40**	0.29	3.11	0.15	6788.05	0.000	0.000	n/a	1.09	n/a
4	12	0.38	6787.60	6787.90	0.30	0.16	1.92	0.09	6787.99	0.000	158.083	6793.00	6793.25 j	0.25**	0.16	2.41	0.09	6793.35	0.000	0.000	n/a	1.00	n/a
5	12	1.50	6783.60	6783.86	0.26*	0.16	9.28	0.21	6784.07	0.000	61.243	6787.90	6788.42	0.52**	0.41	3.65	0.21	6788.63	0.000	0.000	n/a	0.50	n/a
6	12	1.29	6787.75	6788.42	0.67	0.37	2.31	0.19	6788.61	0.000	86.695	6793.25	6793.73 j	0.48**	0.37	3.47	0.19	6793.92	0.000	0.000	n/a	1.38	0.26
7	12	0.99	6793.35	6793.73	0.38	0.27	3.62	0.16	6793.89	0.000	39.867	6795.95	6796.37	0.42**	0.31	3.19	0.16	6796.53	0.000	0.000	n/a	0.86	0.14
8	12	0.26	6795.80	6796.37	0.57	0.12	0.56	0.07	6796.44	0.000	88.000	6801.50	6801.71 j	0.21**	0.12	2.18	0.07	6801.78	0.000	0.000	n/a	1.16	n/a
9	12	0.22	6801.60	6801.71	0.11	0.05	4.72	0.07	6801.78	0.000	72.000	6810.40	6810.59	0.19**	0.11	2.08	0.07	6810.66	0.000	0.000	n/a	1.09	0.07
10	12	0.03	6810.50	6810.59	0.09	0.02	0.83	0.02	6810.62	0.000	162.000	6821.50	6821.57 j	0.07**	0.02	1.23	0.02	6821.59	0.000	0.000	n/a	1.00	0.02
11	12	1.35	6772.00	6772.75	0.75	0.38	2.15	0.19	6772.94	0.000	32.000	6772.30	6772.79 j	0.49**	0.38	3.52	0.19	6772.98	0.000	0.000	n/a	0.50	n/a
12	12	1.25	6772.45	6772.80	0.35*	0.25	5.03	0.18	6772.99	0.000	47.666	6773.15	6773.62	0.47**	0.36	3.43	0.18	6773.81	0.000	0.000	n/a	1.00	0.18
13	24	3.77	6803.20	6804.54	1.34	0.94	1.69	0.25	6804.79	0.000	13.951	6804.80	6805.48 j	0.68**	0.94	4.00	0.25	6805.73	0.000	0.000	n/a	1.40	0.35
14	12	0.86	6805.55	6805.76	0.21*	0.12	7.10	0.14	6805.91	0.000	39.999	6807.62	6808.01	0.39**	0.28	3.05	0.14	6808.15	0.000	0.000	n/a	1.00	0.14
15	18	2.91	6805.30	6805.67	0.37*	0.34	8.53	0.25	6805.92	0.000	27.659	6806.30	6806.95	0.65**	0.73	3.98	0.25	6807.19	0.000	0.000	n/a	1.73	0.43
16	12	0.84	6806.60	6806.95	0.35	0.24	3.46	0.14	6807.09	0.000	24.813	6807.00	6807.38	0.38**	0.28	3.03	0.14	6807.53	0.000	0.000	n/a	1.00	0.14
17	12	1.84	6806.60	6806.95	0.35	0.24	7.58	0.24	6807.19	0.000	188.500	6815.30	6815.88	0.58**	0.47	3.92	0.24	6816.12	0.000	0.000	n/a	1.17	n/a
18	12	0.52	6815.30	6815.88	0.58	0.20	1.11	0.11	6815.99	0.000	24.000	6815.70	6816.00 j	0.30**	0.20	2.64	0.11	6816.11	0.000	0.000	n/a	1.00	n/a
19	12	1.28	6815.55	6815.88	0.33	0.22	5.73	0.19	6816.06	0.000	59.792	6818.35	6818.83	0.48**	0.37	3.46	0.19	6819.01	0.000	0.000	n/a	0.86	0.16
20	12	0.81	6818.20	6818.83	0.63	0.27	1.56	0.14	6818.97	0.000	24.000	6818.60	6818.98 j	0.38**	0.27	3.00	0.14	6819.12	0.000	0.000	n/a	1.00	n/a
21	12	0.14	6818.20	6818.83	0.63	0.08	0.27	0.05	6818.88	0.000	202.000	6821.65	6821.80 j	0.15**	0.08	1.84	0.05	6821.86	0.000	0.000	n/a	0.50	n/a
22	12	0.10	6821.75	6821.86	0.10*	0.04	2.28	0.04	6821.90	0.000	24.000	6822.05	6822.18	0.13**	0.06	1.69	0.04	6822.22	0.000	0.000	n/a	1.00	n/a

see HGL/EGL profiles for line no. designation

Project File: CRV\_MINOR.str

Number of lines: 22

Run Date: 12/2/2021

Notes: \* depth assumed; \*\* Critical depth.; j-Line contains hyd. jump ; c = cir e = ellip b = box

# Hydraulic Grade Line Computations

Major Event flows for Copper Ridge Storm Sewers (leading to PLDF)

Line	Size (in)	Q (cfs)	Downstream								Len (ft)	Upstream								Check		JL coeff (K)	Minor loss (ft)
			Invert elev (ft)	HGL elev (ft)	Depth (ft)	Area (sqft)	Vel (ft/s)	Vel head (ft)	EGL elev (ft)	Sf (%)		Invert elev (ft)	HGL elev (ft)	Depth (ft)	Area (sqft)	Vel (ft/s)	Vel head (ft)	EGL elev (ft)	Sf (%)	Ave Sf (%)	Enrgy loss (ft)		
1	24	23.45	6775.00	6776.86	1.86	2.87	7.70	1.04	6777.90	0.000	31.000	6777.80	6779.52 j	1.72**	2.87	8.17	1.04	6780.56	0.000	0.000	n/a	0.50	0.52
2	12	9.95	6780.00	6780.70	0.70*	0.59	16.86	2.50	6783.20	0.000	32.000	6783.00	6783.99	0.99**	0.78	12.68	2.50	6786.49	0.000	0.000	n/a	1.50	n/a
3	12	3.60	6783.10	6783.99	0.89	0.68	4.86	0.43	6784.43	0.000	45.779	6787.50	6788.31 j	0.81**	0.68	5.29	0.43	6788.74	0.000	0.000	n/a	1.09	0.47
4	12	1.50	6787.60	6788.31	0.71	0.41	2.52	0.21	6788.52	0.000	158.083	6793.00	6793.52 j	0.52**	0.41	3.65	0.21	6793.73	0.000	0.000	n/a	1.00	n/a
5	12	5.95	6783.60	6784.15	0.55*	0.44	13.51	0.92	6785.07	0.000	61.243	6787.90	6788.85	0.95**	0.77	7.70	0.92	6789.78	0.000	0.000	n/a	0.50	n/a
6	12	5.11	6787.75	6788.85	1.00	0.76	6.51	0.66	6789.51	1.755	86.695	6793.25	6794.17 j	0.92**	0.76	6.75	0.71	6794.88	1.522	1.638	n/a	1.38	0.98
7	12	3.90	6793.35	6794.17	0.82	0.69	5.65	0.48	6794.65	0.000	39.867	6795.95	6796.79	0.84**	0.70	5.55	0.48	6797.27	0.000	0.000	n/a	0.86	n/a
8	12	1.00	6795.80	6796.79	0.99	0.31	1.28	0.16	6796.95	0.000	88.000	6801.50	6801.92 j	0.42**	0.31	3.20	0.16	6802.08	0.000	0.000	n/a	1.16	0.18
9	12	0.85	6801.60	6801.92	0.32	0.22	3.93	0.14	6802.06	0.000	72.000	6810.40	6810.79	0.39**	0.28	3.04	0.14	6810.93	0.000	0.000	n/a	1.09	0.16
10	12	0.10	6810.50	6810.79	0.29	0.06	0.54	0.04	6810.83	0.000	162.000	6821.50	6821.63 j	0.13**	0.06	1.69	0.04	6821.67	0.000	0.000	n/a	1.00	n/a
11	12	5.40	6772.00	6772.97	0.97	0.78	6.95	0.75	6773.72	1.718	32.000	6772.30	6773.57	1.00	0.79	6.88	0.73	6774.31	1.959	1.839	0.588	0.50	0.37
12	12	5.00	6772.45	6773.94	1.00	0.79	6.37	0.63	6774.57	1.680	47.666	6773.15	6774.74	1.00	0.79	6.37	0.63	6775.37	1.680	1.680	0.801	1.00	0.63
13	24	14.96	6803.20	6804.90	1.70	2.34	5.27	0.64	6805.53	0.000	13.951	6804.80	6806.19 j	1.39**	2.34	6.41	0.64	6806.83	0.000	0.000	n/a	1.40	n/a
14	12	3.42	6805.55	6806.19	0.64	0.53	6.41	0.41	6806.60	0.000	39.999	6807.62	6808.41	0.79**	0.67	5.14	0.41	6808.82	0.000	0.000	n/a	1.00	n/a
15	18	11.54	6805.30	6806.19	0.89	1.10	10.53	0.79	6806.98	0.000	27.659	6806.30	6807.59	1.29**	1.62	7.12	0.79	6808.38	0.000	0.000	n/a	1.73	1.36
16	12	3.34	6806.60	6807.59	0.99	0.66	4.26	0.40	6807.99	0.000	24.813	6807.00	6807.78 j	0.78**	0.66	5.07	0.40	6808.18	0.000	0.000	n/a	1.00	n/a
17	12	7.29	6806.60	6807.59	0.99	0.78	9.29	1.35	6808.95	0.000	188.500	6815.30	6816.28 j	0.98**	0.78	9.33	1.35	6817.63	0.000	0.000	n/a	1.17	n/a
18	12	2.06	6815.30	6816.28	0.98	0.50	2.64	0.26	6816.54	0.000	24.000	6815.70	6816.31 j	0.61**	0.50	4.09	0.26	6816.57	0.000	0.000	n/a	1.00	n/a
19	12	5.08	6815.55	6816.28	0.73	0.61	8.29	0.70	6816.98	0.000	59.792	6818.35	6819.27	0.92**	0.76	6.72	0.70	6819.97	0.000	0.000	n/a	0.86	0.60
20	12	3.24	6818.20	6819.27	1.00	0.65	4.13	0.26	6819.54	0.706	24.000	6818.60	6819.37 j	0.77**	0.65	4.98	0.39	6819.76	0.794	0.750	0.180	1.00	0.39
21	12	0.54	6818.20	6819.27	1.00	0.20	0.69	0.01	6819.28	0.020	202.000	6821.65	6821.96 j	0.30**	0.20	2.66	0.11	6822.07	0.480	0.250	n/a	0.50	n/a
22	12	0.39	6821.75	6821.96	0.20	0.12	3.38	0.09	6822.05	0.000	24.000	6822.05	6822.31	0.26**	0.16	2.43	0.09	6822.40	0.000	0.000	n/a	1.00	0.09

see HGL/EGL profiles for line no. designation

Project File: CRV.stm

Number of lines: 22

Run Date: 12/2/2021

Notes: \* depth assumed; \*\* Critical depth.; j-Line contains hyd. jump ; c = cir e = ellip b = box

L. Scope Approval Form

CITY OF STEAMBOAT SPRINGS ENGINEERING STANDARDS

**Standard Form No. 5 Drainage and Stormwater Treatment Scope Approval Form**

Prior to starting a development plan and before the first drainage submittal, a Drainage and Stormwater Treatment Scope Approval Form must be submitted for review and signed by the City Engineer. A signed form shall also be included in every drainage submittal as Attachment A. This Scope Approval Form is for City requirements only. Values may be approximate. The City encourages supporting calculations and figures to be attached.

Project Information	
Project name:	Lot 1 Steamboat Airpark Apartments
Project location:	Lot 1 Steamboat Airpark
Developer name/contact info:	Ken Marsh, 303-217-6080
Drainage engineer name/contact info:	Matthew McLeod, PE 248-444-3268
Application Type:	Development Plan
Proposed Land Use:	Multiple Apartment Buildings
Project Site Parameters	
Total parcel area (acres):	15.02
Disturbed area (acres):	9
Existing impervious area (acres, if applicable):	N/A
Proposed new impervious area (acres):	~5
Proposed total impervious area (acres):	~5
Proposed number of project outfalls:	1 Pond, multiple existing sheet flow outfalls
Number of additional parking spaces:	~159 outside, ~155 inside
Description and site percentage of existing cover/land use(s):	Site is currently vacant
Description and site percentage of proposed cover/land use(s):	There will be seven apartment buildings with associate streets and parking lots.
Expected maximum proposed conveyance gradient (%):	10%
Description of size (acres) and cover/land use(s) of offsite areas draining to the site	There is a large vacant parcel to the north and east that sheet flows into the lot.



CITY OF STEAMBOAT SPRINGS ENGINEERING STANDARDS

Project Permanent Stormwater Treatment	
Justification of choice of proposed design standard, including how the site meets the constrained redevelopment standard, infiltration test results, etc.:	The site is currently vacant so all flow from the proposed disturbance will need to be treated.
Concept-level permanent stormwater treatment facility design details (type, location of facilities, proprietary structure selection, treatment train concept, etc.):	Water quality porous landscape detention pond will be designed as a part of the drainage study.
Proposed LID measures to reduce runoff volume:	Grass lined water quality swales, reveg
Will treatment evaluation include off-site, pass through flow (circle):	<input checked="" type="radio"/> YES      NO

**Approvals**

Matthew McLeod, PE Four Points Engineering      **3/18/2021**      **248-444-3268**

Prepared By:      Date      Phone number  
 (Insert drainage engineer name & firm)

Approved By:      **3/2/2021**  
**S.H.King for**

Printed Name:      Date  
 City Engineer

M. Standard Forms No. 3 and No. 4

# CITY OF STEAMBOAT SPRINGS ENGINEERING STANDARDS

## Standard Form No. 3 Final Drainage Study Checklist

### Instructions:

1. The applicant shall identify with a “check mark” if information is provided with letter. If applicant believes information is not required, indicate with “N/A” and attach separate sheet with explanation.
2. The reviewer will determine if information labeled “N/A” is required and whether additional information must be submitted.

### I. General

- A. Report typed and legible in 8½” x 11” format.
- B. Report bound (comb, spiral, or staple – no notebook).
- C. Drawings that are 8½ x 11 or 11 x 17 bound within report, larger drawings (up to 24 x 36) included in a pocket attached to the report. Drawings shall be at an appropriate size and scale to be legible and include project area.

### II. Cover

- A. Report Type – Final Drainage Study.
- B. Project Name, Subdivision, Original Date, Revision Date.
- C. Preparer’s name, firm, address, phone number.
- D. “DRAFT” for 1<sup>st</sup> submittal and revisions; “FINAL” once approved.

### III. Title Sheet

- A. Table of Contents.
- B. Certification, PE Stamp, signature, and date from licensed Colorado PE.
- C. Note: City of Steamboat Springs plan review and approval is only for general conformance with City design criteria and the City code. The City is not responsible for the accuracy and adequacy of the design, dimensions, and elevations that shall be confirmed and correlated at the job site. The City of Steamboat Springs assumes no responsibility for the completeness or accuracy of this document.

### IV. Introduction

- A. Description of site location, size in acres, existing and proposed land use, and any pertinent background info.
- B. Reference planning application type and plan set date and preparer.
- C. Identify drainage reports for adjacent development.

### V. Drainage Criteria and Methodology Used

- A. Identify design rainfall and storm frequency.
- B. Identify the runoff calculation method used.
- C. Identify culvert and storm sewer design methodology.
- D. Identify detention discharge and storage methodology.
- E. Discuss HEC-HMS methodologies and parameters, if HEC-HMS is used.

# CITY OF STEAMBOAT SPRINGS ENGINEERING STANDARDS

## VI. Existing Conditions (Pre-Development/Historic)

- A. Indicate ground cover, imperviousness, topography, and size of site (acres).
- B. Describe existing stormwater system (sizes, materials, etc.).
- C. Describe other notable features (canals, major utilities, etc.).
- D. Note site outfall locations and ultimate outfall location (typically Yampa River).
- E. Note capacity of existing system and identify any constraints.
- F. Identify NRCS soil type.
- G. Discuss any existing easements.
- H. Identify the FEMA Map reviewed, if site is in floodplain/way, and zone designation.

## VII. Proposed Conditions

- A. Indicate ground cover, imperviousness, topography, and disturbed area (acres).
- B. Describe proposed stormwater system (sizes, materials, etc.).
- C. Describe proposed outlets and indicate historic and proposed flow for each.
- D. Include calculations for all culverts, ditches, ponds, etc. in appendix.
- E. Include a summary table for the 5- and 100-year events showing historic flow and proposed flow for total site and each basin.
- F. Discuss proposed easements.
- G. Describe off-site flows to be passed thru site.
- H. Summarize any impacts to downstream properties or indicate none. Reference CLOMR/LOMR and impacts.
- I. Detention Ponds.
  - 1. Indicate pond volume and area (size and depth) requirement.
  - 2. Indicate release rates.
  - 3. Discuss outfall design, location, and overflow location.
  - 4. Discuss maintenance requirements.
- J. Curb and Gutter
  - 1. Indicate gutter capacity.
  - 2. Indicate curb capacity.
  - 3. Indicate design velocity
  - 4. Indicate design depth of flow in street.
- K. Culverts
  - 1. Indicate whether each culvert is under inlet or outlet control.
  - 2. Show that headwater is less than the maximum allowable.
  - 3. Indicate design velocity.
  - 4. Indicate required and provided flow rates.
  - 5. Discuss whether outlet protection is required and what will be used.
- L. Inlets
  - 1. Indicate inlet capacity.
  - 2. Indicate the type of inlet(s) used.
- M. Channels
  - 1. Indicate design velocity (and type of dissipation if required).
  - 2. Indicate required and provided flow capacity.
  - 3. Show critical cross-section(s) including water surface.
- N. Site Discharge
  - 1. Discuss use and design of detention to ensure discharge is less than or equal to historic flow.
  - 2. Provide documentation that downstream facilities are adequate and no adverse impacts to downstream property owners (i.e. no rise certification)

# CITY OF STEAMBOAT SPRINGS ENGINEERING STANDARDS

## VIII. Post Construction Stormwater Management

- A. Discuss in general terms which permanent BMP practices will be used to control pollutant and sediment discharge after construction is complete. Exhibit A, Storm Water Quality Plan shall be attached that will give details (see separate checklist)

## IX. Conclusions

- A. Provide general summary.
- B. Note if site complies with criteria and any variances to criteria.
- C. Indicate if peak proposed flow is less than, equal to, or greater than peak historic flow for each outfall, design point, and for the total site.
- D. List proposed new stormwater system requirements.

## X. References

- A. Provide a reference list of all criteria, master plans, drainage reports and technical information used.

## XI. Tables

- A. Include a copy of all tables prepared for the study.

## XII. Figures

- A. Vicinity Map.
- B. Site Plan (include the horizontal and vertical datum used and all benchmarks).
- C. Existing conditions.
  - 1. Delineate existing basin boundaries.
  - 2. Delineate offsite basins impacting the site.
  - 3. Show existing and proposed topography at an interval of at least 2-ft.
  - 4. Show existing runoff flow arrows.
  - 5. Show existing stormwater features (structures, sizes, materials, etc.).
  - n/a 6. Show floodplain limits and information.
  - 7. For each basin show bubble with basin number, acreage and % impervious.
  - 8. For each outlet show bubble with acreage and historic flow and proposed flow or provide information in summary table on figure.
- D. Proposed Conditions
  - 1. Delineate proposed basin boundaries.
  - 2. Show proposed runoff flow arrows.
  - 3. Show existing and proposed topography at an interval of at least 2-ft.
  - 4. For each basin show bubble with basin number, acreage and percent impervious or provide a summary table or figure.
  - 5. For each outlet show bubble with acreage, historic flow, and proposed flow or provide a summary table or figure.
  - N/A 6. Show floodplain limits and information.
  - 7. Show proposed building footprints and FFE for commercial and multi-family
  - 8. Show property lines and easements (existing and proposed).
  - N/A 9. Label public and private facilities. A general note can be placed on the plans in lieu of labeling all facilities, if applicable.

CITY OF STEAMBOAT SPRINGS ENGINEERING STANDARDS

**XIII. Appendices**

- A. Runoff Calculations.
- B. Culvert Calculations.
- C. Pond Calculations.
- D. Other Calculations.

**Acknowledgements**

Standard Form No. 3 was prepared by: Joe Wiedemeier

4/13/2021

Date

**Include Attachment A – Scope Approval Form (see Standard Form No. 5)**

**Include Attachment B – Storm Water Quality Plan (see Standard Form No. 4)**

# CITY OF STEAMBOAT SPRINGS ENGINEERING STANDARDS

## Standard Form No. 4 Stormwater Quality Plan Checklist

This list is not an exhaustive list of every possible item that may be required or requested in a Stormwater Quality Plan but provides a general guideline for preparation of the Stormwater Quality Plan.

### Instructions:

1. The applicant shall identify with a “check mark” if information is provided within the Stormwater Quality Plan. If applicant believes information is not required, indicate with “N/A” and attach separate sheet with explanation. If information is included with the associated drainage letter or study, indicated with a “D.”
2. The reviewer will determine if information labeled “N/A” is required and whether additional information must be submitted.

### I. General

- A. Report typed and legible in 8½” x 11” format.
- B. Report bound (comb, spiral, or staple – no notebook) and in digital PDF format.
- C. Drawings that are 11” x 17” bound within letter, larger drawings (up to 24” x 36”) included in a pocket attached to the letter, and a digital PDF copy. Drawings shall be at an appropriate size and scale to be legible and include project area.

### II. Cover

- A. Report Type – Stormwater Quality Plan.
- B. Project Name, Subdivision or Development, Original Date, Revision Date.
- C. Preparer’s name, firm, address, and phone number.
- D. “DRAFT” for 1<sup>st</sup> submittal and revisions; “FINAL” once approved.

### III. Title Sheet

- A. Table of Contents.
- B. Certification, PE Stamp, signature and date from licensed Colorado PE (for Final).
- C. Note: City of Steamboat Springs plan review and approval is only for general conformance with City design criteria and City code. The City is not responsible for the accuracy and adequacy of the design, dimensions, and elevations that shall be confirmed and correlated at the job site. The City of Steamboat Springs assumes no responsibility for the completeness or accuracy of this document.

### IV. Introduction and Background

- A. Description of site location, study limits, size in acres, existing and proposed land use, soil data, permeability of the site, drainage patterns, and any pertinent background info.
- B. State purpose and goal of Stormwater Quality Plan and report along with any special requirements of the desired outcome.
- C. List any project stakeholders and/or requestors.
- D. Describe the background of the flooding source and any previous studies.

CITY OF STEAMBOAT SPRINGS ENGINEERING STANDARDS

**V. Design Criteria and Methodology Used**

- A. Identify design rainfall and storm frequency used to design permanent stormwater treatment facilities.
- B. Identify the runoff calculation method used to design permanent stormwater treatment facilities.
- C. Identify the standard the design will meet and the means and methodologies by which it will use to meet the standard.
- D. Provide all details supporting the use of the selected design standard.

**VI. Proposed Conditions**

- A. Identify total site area, total site imperviousness, area to be treated, and impervious area to be treated. Include justification for treating less than the total site area.
- B. Describe potential site contaminant sources including sediment.
- C. Identify source and quantity of on-site and off-site stormwater flows that need to be managed and how they will be managed.
- D. For each permanent treatment facility, identify the design standard, MDCIA level (if applicable), area treated (& percentage of total), imperviousness of area treated, C values of area treated, soil types, and all pertinent data for design.
- E. Volume based facilities: Provide total storage pond volume, WQCV, drain time, release rate, sediment storage, outlet & overflow structures, area and depth of pond, micropool, forebays, etc. (include all calculations in the appendix).
- F. Flow based facilities: Provide design flow rate and all treatment calculations and how flows larger than the water quality design flow rate will be handled. If proprietary facilities are proposed, provide the justification and sizing requirements from manufacturer.
- G. If stormwater detention is provided, discuss how water quality is provided within the detention facility. No underground detention is allowed.

**VII. Operation and Maintenance Plan Requirements**

See template O&M plan and guidance document.

- A. Describe general project information, facility description, ROW and access information, vegetation management, hydraulic design parameters, environmental permitting, snow and ice control, and additional pertinent information in the notes.
- B. Indicate, describe, and detail the permanent stormwater treatment facilities.
- C. Include section details where necessary of the permanent treatment facilities.
- D. Provide an inspection and maintenance schedule and procedure of permanent treatment facilities and who is responsible for them.
- E. Identify design specifications for construction.

**Acknowledgements**

Standard Form No. 4 prepared by: Joe Wiedemeier

4/13/2021

Date

**Include appropriate Project Sheet(s) and Design Checklist(s) (See Section 5.12)  
Include this form as part of the Stormwater Quality Plan.**

N. Project Sheets for Water Quality

CITY OF STEAMBOAT SPRINGS ENGINEERING STANDARDS

PROJECT SHEET – BASE DESIGN STANDARDS (Site is not constrained)

Complete a Project Sheet for each project that includes Permanent Stormwater Treatment Facilities.

**SITE INFORMATION**

Project Name: Copper Ridge Village		
Project Location: 8888 Gloria Gossard		
Submitted Date: 4/22/2021	Submitted By: Matthew McLeod	
Acreage Disturbed: 11.1		
Existing Impervious: 2%	New Net Impervious: 44%	
Review Date:	Reviewed By:	
<b>Preparer</b>	<b>City</b>	<b>Requirements</b>
		Design Details are included for all Treatment Facilities
		List or include a description of any source controls or other non-structural practices:

**DESIGN STANDARDS**

Multiple Design Standards may be used on a site, as necessary, to meet the requirements, but only one Design Standard may be used for each treatment facility’s tributary area. Evaluation of suitability of permanent stormwater treatment facilities is based on meeting the specified Design Standard and ease of long-term maintenance. Facilities must be designed in accordance with the most current versions of the City’s Engineering Standards and Volume 3 of the USDCM and meet the specific requirements for each Design Standard used.

1. Indicate below, which Design Standard(s) will be used for the project, and
2. Complete a separate, corresponding Design Standards checklist for each facility (e.g., WQCV)

<i>Design Standard</i>	<i>Quantity</i>	<i>Tributary Area</i>	<i>Location/Identifying information</i>
WQCV	3863	8.9 acres	Porous Landscape Detention Facility, by the main entrance
Pollutant Removal			
Runoff Reduction			

CITY OF STEAMBOAT SPRINGS ENGINEERING STANDARDS

## DESIGN CHECKLIST – Water Quality Capture Volume (WQCV) Standard

### WQCV STANDARD Criteria

Treatment facilities must be designed to provide treatment and/or infiltration of the WQCV for 100% of the site. Under certain conditions, up to 20% of the site may be excluded, not to exceed 1 acre. This may apply if it is not practicable to capture runoff from portions of the site and where it is not practicable to construct a separate treatment facility for those same portions of the site.

*Complete checklist if using the WQCV Standard to meet Design Standard requirements.*

Project Name:		<b>Copper Ridge Village</b>	
Preparer	City	Requirements	
		Facilities provide treatment and/or infiltration of the WQCV for 100% of the site	
		% of site treated: 80%	
		Facility Type: Porous Landscape Detention Facility	Facility Location: <b>By the entrance</b>
		See Drainage Report section: Chapter 4, Section K	

*If less than 100% of the site is treated, complete the following:*

Preparer	City	Requirements	
		% of site not treated by control measures (not to exceed 20% or 1 acre):	
		20% %	2.2 Size (acres)
		Provide explanation of why the excluded area is impractical to treat: See Chapter 4 Section A of the report. Much of the untreated area will be finished with vegetated slopes, similar to that of existing conditions. The largest section of untreated area is 1.3 acres in size and this is the emergency access.	
		Provide explanation of why another facility is not practicable for the untreated area: There would have to be numerous facilities treating fully vegetated but developed areas.	

0. PLDF Operation and Maintenance Plans (OM1 & OM2)

# POROUS LANDSCAPE DETENTION POND FOR COPPER RIDGE VILLAGE OWNERSHIP AND MAINTENANCE PLAN

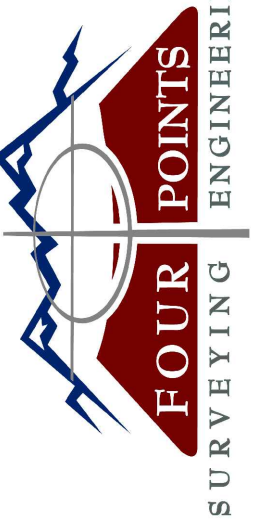

440 S. Lincoln Ave, Suite 4A  
P.O. Box 775966  
Steamboat Springs, CO 80487  
(970)-871-8772  
www.fourpointsse.com

NO.	DATE	REVISIONS

**COPPER RIDGE VILLAGE**  
ADDRESS TBD  
STEAMBOAT SPRINGS, CO 80487

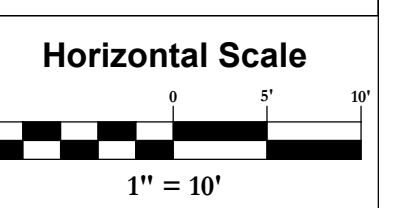

DATE: 4/13/2021  
JOB #: 1992-001  
DRAWN BY: JLW  
DESIGN BY: JLW  
REVIEW BY: JDM

**OWNERSHIP &  
MAINTENANCE  
PLAN**

DRAWING: SHEET #  
**WQ1**

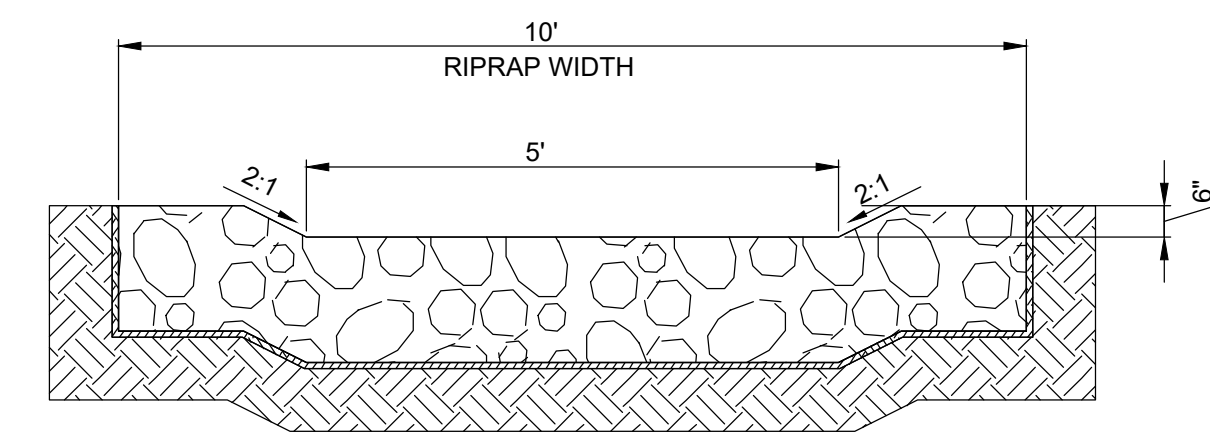

EMERGENCY OVERFLOW  
N.T.S.

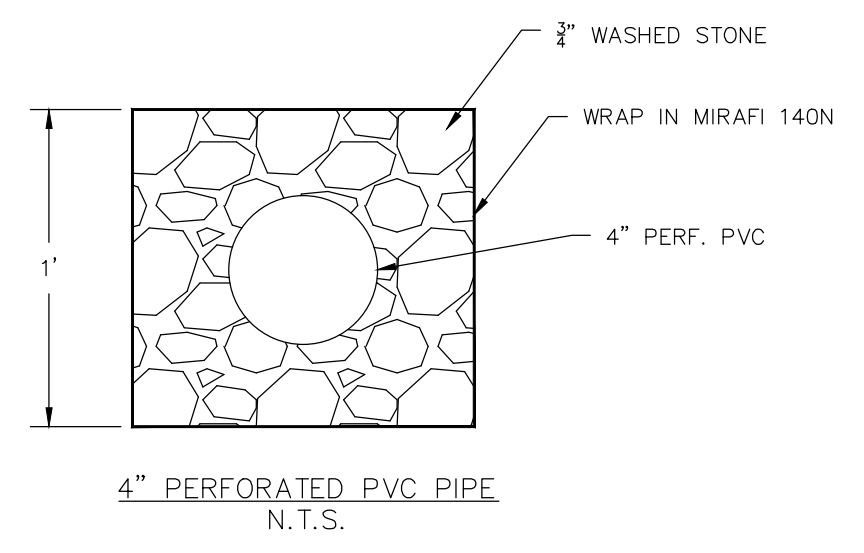

4" PERFORATED PVC PIPE  
N.T.S.

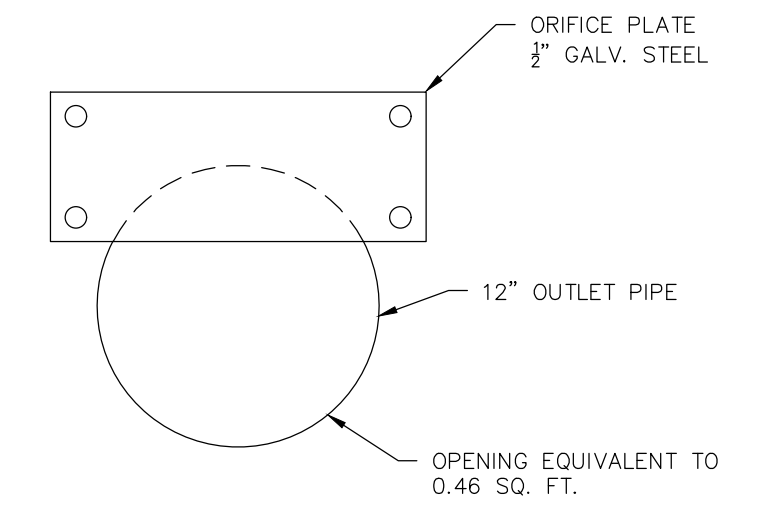

12" OUTLET PIPE ORIFICE PLATE DETAIL  
1"=1'

DETENTION POND CROSS SECTION DETAIL: (1"=20')  
(TO BE COMPLETED FOR FINAL PLAN SUBMITTAL)

DESIGN VOLUME SPECIFICATIONS:  
WOCV: 3,958 CU. FT.  
5-YEAR VOL: 6,336 CU. FT.  
100-YEAR VOL: 21,487 CU. FT.

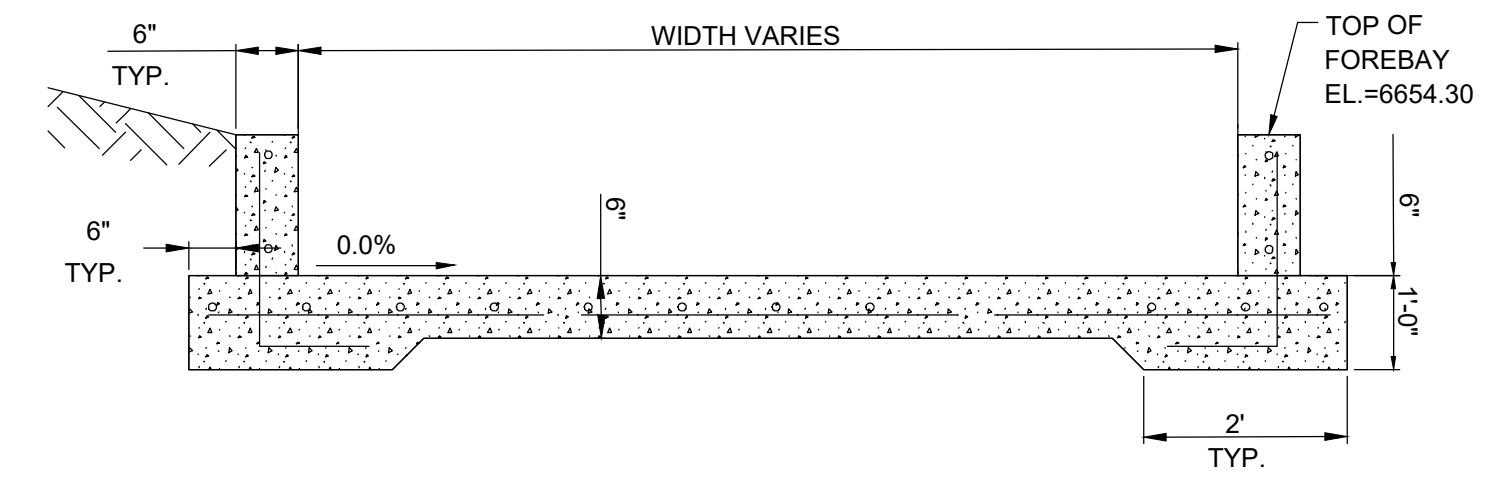

FOREBAY SECTION A-A  
N.T.S.

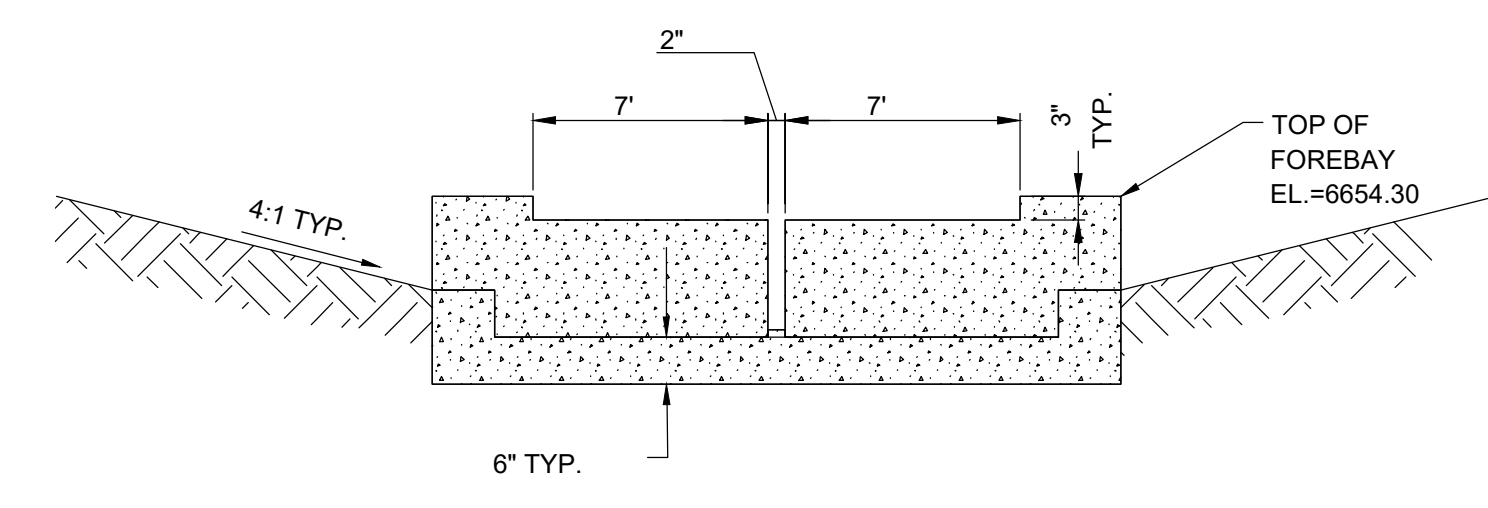

FOREBAY SECTION B-B  
N.T.S.

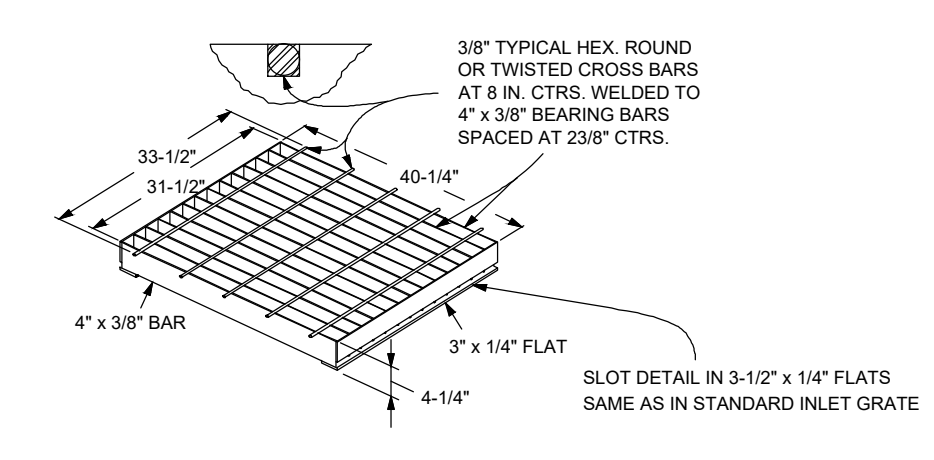

TYPE C INLET CLOSE MESH GRATE  
N.T.S.

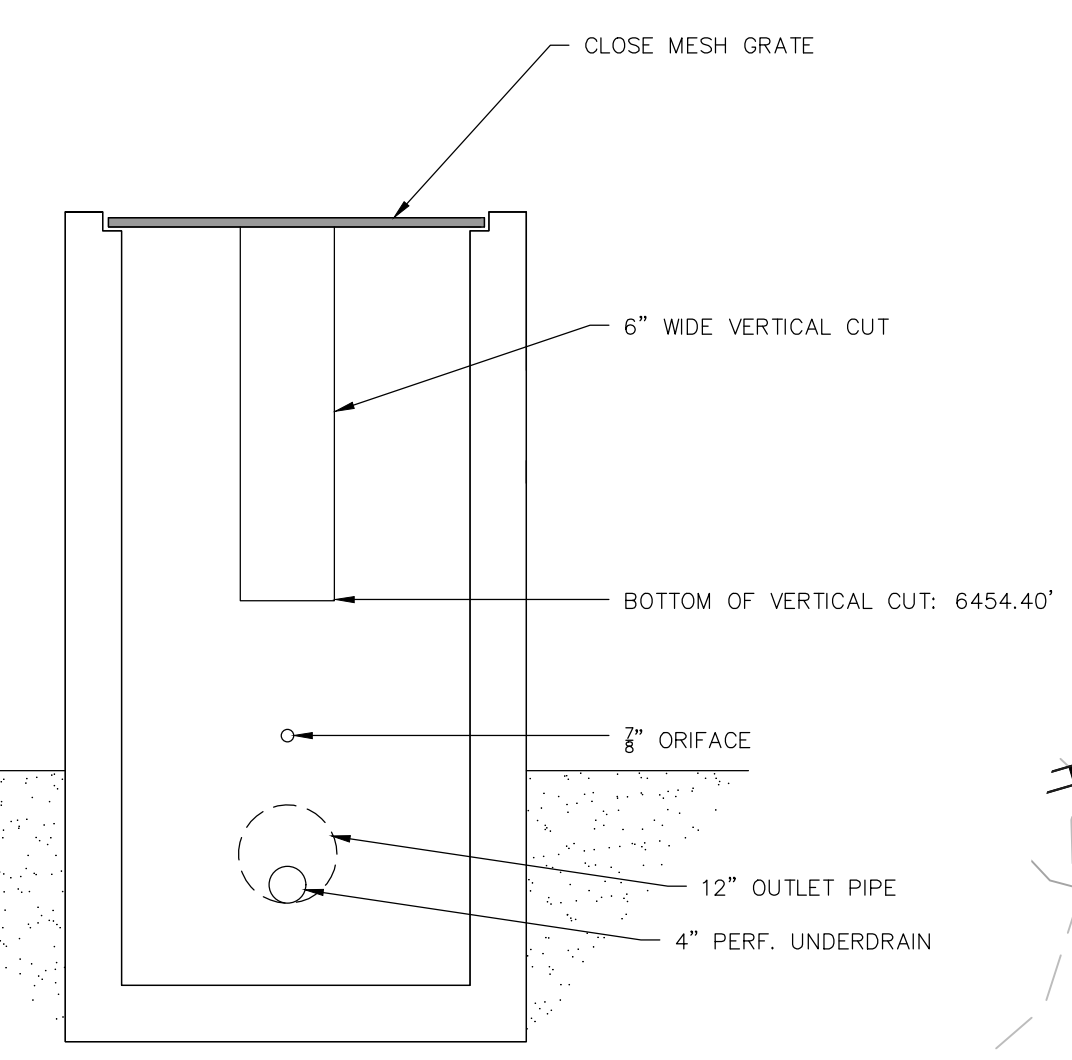

MODIFIED TYPE C INLET FRONT VIEW  
N.T.S.

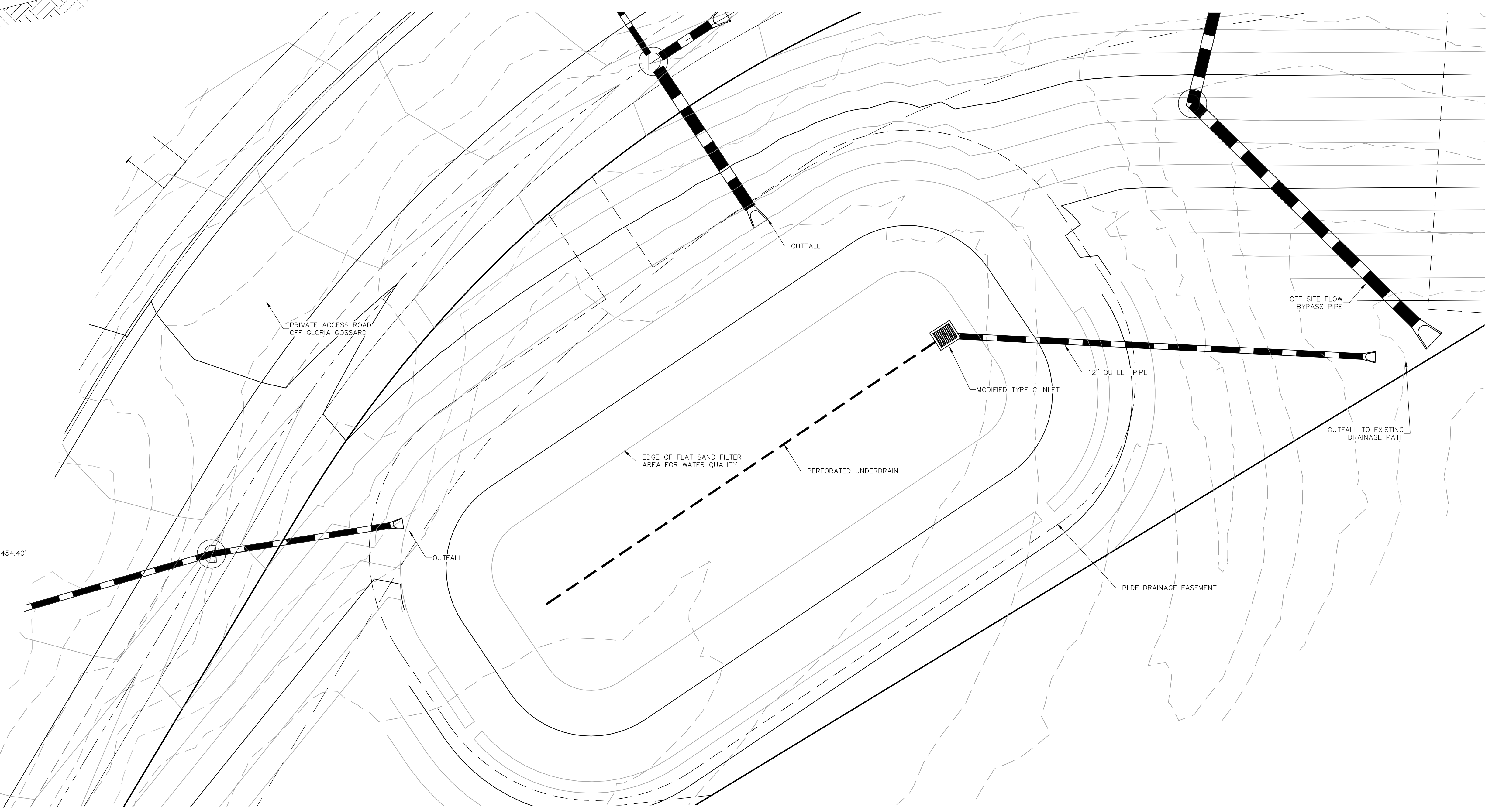

DRAWING:

