



---

Ph: 970-871-6772 · Fax: 970-879-8023 · P.O. Box 775966 · Steamboat Springs, Colorado 80477

## **Stormwater Management Plan (SWMP)**

**Prepared for**

### **Field Entrance Driveway for Lot 1 West Acres Ranch Subdivision Exemption Plat**

**8888 Gloria Gossard Parkway  
Steamboat Springs, Colorado**

**May, 2018**

**Revised: June, 2018**

**Prepared By:**

**Four Points Surveying & Engineering – Steamboat Springs, CO**

**CDPHE Certification # COR03S672**

**SWMP and Administrator Acknowledgment**

This SWMP for the Overlook Park Subdivision Project described herein was prepared by me or under my direct supervision in accordance with the provisions of the Colorado Department of Public Health and Environment (CDPHE) guidelines. The SWMP has been prepared in accordance with good engineering, hydrologic and pollution control practices. I acknowledge responsibility for preparation of this SWMP Plan.

\_\_\_\_\_  
Walter Magill, P.E. - Four Points Surveying and Engineering  
Date \_\_\_\_\_

**Contractor's/Subcontractor's Certification**

"I hereby certify under penalty of law that I understand and agree to comply with the terms and conditions of the SWMP and agree to implement any corrective actions identified by the qualified inspector during a site inspection. I also understand that the owner or operator must comply with the terms and conditions of the most current version of the CDPHE general permit for stormwater discharges from construction activities and that it is unlawful for any person to cause or contribute to a violation of water quality standards. Furthermore, I am aware that there are significant penalties for submitting false information, that I do not believe to be true, including the possibility of fine and imprisonment for knowing violations."

**Contractor**

\_\_\_\_\_  
(Company)

\_\_\_\_\_  
(Street / P.O. Box)

\_\_\_\_\_  
(City, State, Zip)

\_\_\_\_\_  
(Phone)

Signature \_\_\_\_\_

Date \_\_\_\_\_

## Table of Contents

<b>1.0 Introduction</b> .....	1
<b>1.1 Contacts</b> .....	1
<b>2.0 Project Description and Location</b> .....	2
<b>2.1 Construction Schedule</b> .....	2
<b>2.2 Sequence and Description of Major Construction Activities</b> .....	2
<b>2.3 Developed Conditions and Disturbance Phasing</b> .....	2
<b>2.4 Potential Sources of Pollution Associated with Construction Activities</b> .....	2
2.4.1 Sediment to Stormwater.....	2
2.4.2 Other Sources of Pollution (Non-Sediment).....	2
<b>3.0 Existing Conditions and Surrounding Areas</b> .....	3
<b>3.1 General Conditions and Vegetation</b> .....	3
<b>3.2 Topography</b> .....	3
<b>3.3 Soils and Subsurface Conditions</b> .....	3
<b>4.0 Utilized Project BMPs</b> .....	4
<b>4.1 Structural BMPs</b> .....	4
<b>4.2 Non-Structural BMPs</b> .....	5
<b>4.3 Stormwater BMP Construction Phasing</b> .....	6
4.3.1 Before Grading.....	6
4.3.2 During Grading.....	6
4.3.3 During Construction.....	6
4.3.4 Final Stabilization .....	7
<b>5.0 Active Construction Component</b> .....	7
<b>5.1 Potential Pollutant Sources from Construction Activities</b> .....	7
<b>5.2 Stabilized Construction Entrances Specifications</b> .....	7
<b>5.3 Sediment and Dust Control Specifications for Sheet Flow Areas and Stockpiles</b> .....	7
<b>5.4 Sediment Control Specifications for Concentrated Flow Areas</b> .....	8
<b>5.5 Runoff Control Measures</b> .....	8
<b>5.6 Stormwater Outlet Protection Specifications</b> .....	8
<b>5.7 Seasonal Temporary Surface Stabilization Methods</b> .....	8
<b>5.8 Permanent Surface Stabilization Specifications</b> .....	8
<b>5.9 Material Handling and Spill Prevention Plan</b> .....	8
<b>6.0 Inspections and Recordkeeping</b> .....	9
<b>6.1 Inspections Timing and Scope</b> .....	10

**6.2 Reporting** ..... 10  
**6.3 State and Local Regulation Compliance**..... 10  
**7.0 SWMP and Inspection Training**..... 10

- APPENDIX A – SWMP Drawings**
- APPENDIX B – Spill Reporting**
- APPENDIX C – BMP Inspection Form**

## **1.0 Introduction**

The U.S. Environmental Protection Agency (EPA) requires a National Pollutant Discharge Elimination System (NPDES) General Permit for stormwater discharges from construction activities that disturb one or more acres of land. For the purposes of the NPDES program, construction activities are defined as clearing, excavating, grading, or other land-disturbing activities. Colorado's Department of Public Safety (CDPS) is an NPDES-approved program with permits issued in accordance with the Environmental Conservation Law (ECL).

The Colorado Department of Public Health and Environment (CDPHE) issued Permit No. COR03S672, CDPS General Permit for Stormwater Discharges from Construction Activities effective February 14 2018, pursuant to Section 402 of the Clean Water Act. Construction activities disturbing greater than one acre of soil is required to obtain a discharge permit for stormwater. Permit No. COR03S672 requires the preparation of a Stormwater Management Plan (SWMP) for the project prior to initiation of construction activities.

The following report outlines the SWMP prepared on behalf of Overlook Park Properties, LLC (Owner) for land development activities including clearing, grading, and access road infrastructure for a entrance driveway for Lot 1 West Acres Ranch Subdivision (Project) in Steamboat Springs, Colorado. The resulting Project is planned to allow access by gravel road to the future West Acres Ranch Subdivision to provide view area and showcase the property. The primary goal of this SWMP is to identify stormwater pollutant sources and identify Best Management Practices (BMPs) to implement that shall reduce or eliminate impacts on water quality. The SWMP shall be implemented at the time the project breaks ground and shall be revised accordingly as construction progresses and design changes are made.

## **1.1 Contacts**

The following contacts for the Owner, Contractor and Engineer are provided. The individuals listed shall be the primary points of contact.

### Owner/Applicant:

Overlook Park Properties, LLC  
Bob Zibbel  
27582 Silver Spur Street  
Steamboat Springs, CO 80487  
Email: [bob@zibell.com](mailto:bob@zibell.com) Phone: (785) 845-3709

### Prime Contractor:

Rogue Resources  
2206 Downhill Drive,  
Steamboat Springs, CO 80487  
Mike Miller (970)-879-7861

### Engineer, SWMP Administrator/Preparer:

Four Points Surveying & Engineering  
440 South Lincoln Avenue Suite 4B  
Steamboat Springs, CO 80487  
Email: [wnmpepls@gmail.com](mailto:wnmpepls@gmail.com) Phone: (970) 871-6772

## **2.0 Project Description and Location**

This project consists of the construction of an access driveway for future development of what will be known as Lot 1 West Acres Ranch Subdivision. The purpose of the driveway is to provide the owner of the property access to the top of the lot in order to plan a future development of a subdivision airpark. Lot 1 consists of 133.9 acres and was platted March 20, 2008. FEMA map panels 08107C0694D and 08107C0713D were reviewed and the entire site is located in Zone X, an area of minimal flood hazard. The access driveway is located in the southeast quarter of the northwest quarter of Section 1, Township 6 North, Range 85 West.

## **2.1 Construction Schedule**

Project construction will occur during the spring of 2018. Initial construction activities, which consist of land development including BMP installations, topsoil stripping, and preliminary grading; will occur in During the Spring and early summer of 2018. Final grading activities and access road construction including import of gravel and compaction work are expected to end mid-summer 2018.

## **2.2 Sequence and Description of Major Construction Activities**

1. Initial ground breaking and subsequent topsoil stripping/stockpiling, cut/fill operations, and preliminary grading.
2. Will consist of access road preparation in the form of grading, installation of gravel subgrades, and subsequent compaction operations for the access roads and entrance.
3. Final grading, finishing/surfacing, and top soiling.
4. Final stabilization and revegetation.

## **2.3 Developed Conditions and Disturbance Phasing**

Excavation and site grading will occur as part of the access driveway development described above. The total area of disturbance is estimated to be 3.85 acres. Approximately 1,800 cubic yards of topsoil will be stripped, stockpiled and set on the lots and open space areas as shown on the SWMP drawings. An estimated 1,400 cubic yards of fill will be imported on site for the preliminary roadway construction.

## **2.4 Potential Sources of Pollution Associated with Construction Activities**

This section identifies the potential sources of sediment, and pollution sources other than sediment, to stormwater runoff.

### **2.4.1 Sediment to Stormwater**

Sediment primarily in the form of silts and clays from the disturbance of soils due to topsoil stripping, overlot grading, stockpiling, excavation, trenching, and haul off will be the largest contributor of potential stormwater pollution on site.

### **2.4.2 Other Sources of Pollution (Non-Sediment)**

Spills or leaks of fluids (e.g. gasoline, diesel, oil, hydraulic fluids, etc.) from the heavy equipment, small equipment, and vehicles used on site are a potential source of pollutants. The Contractor shall implement a spill prevention, control and countermeasure plan for the duration of construction and all heavy

equipment shall remain on site for most of the project. As part of the BMP inspection process, applicable equipment shall be inspected for fluid leaks. Secondary containment shall be utilized for fluid containers and small motorized and construction tools and equipment. There is no anticipation for the storage of any hazardous material on the site.

Trash and debris are another potential source of pollution. Trash and debris shall be properly contained and disposed of. The contractor shall have an appropriately sized waste container at all times to contain trash and debris. Exposed boxes, containers, and materials with plastic wrap shall be properly tied down.

### **3.0 Existing Conditions and Surrounding Areas**

The following section provides a description of the existing conditions of the Project site including general condition, vegetation, topography, soils, and subsurface conditions. A more detailed and technical description of existing conditions including terrain and geology can be found in the geotechnical report prepared for the adjacent Overlook Park Subdivision project. This document can be provided upon request.

#### **3.1 General Conditions and Vegetation**

The parcel that makes up the Project site is currently vacant and is comprised of both undisturbed and previously disturbed rural land with variable terrain. Vegetation consists of a combination of native grasses, weeds, sagebrush, and deciduous brush for a majority of the area. Native vegetative coverage is estimated to range from 70% to 80% across the entire Project site. Existing conditions photos were documented showing the range of vegetative coverage. There are no wetlands mapped on site. Stormwater generally sheet flows down the southwest slope onto the Overlook Park Subdivision project site that is lower in elevation and eventually to a tributary of Slate Creek. Slate Creek is tributary to the Yampa River. Runoff is routed to a small established ditch at the base of the slope and subsequently drains to a small pre-existing detention pond that is currently being utilized as a temporary sedimentation basin.

It is understood that a previous reclaimed access road located to the east of the proposed access driveway has not revegetated and there is currently no erosion control in place. The appropriate erosion control and revegetation measures were evaluated and recommended as part of this SWMP report.

#### **3.2 Topography**

The topography of the site is highly variable and consists of steeply sloping hillsides. An established drainage ditch that generally flows in an east to west direction is located at the base of the hillsides as previously described. The hillsides situated to the north of the drainage generally slope steeply to the south and southwest.

#### **3.3 Soils and Subsurface Conditions**

The soils encountered generally consisted of a layer of topsoil and organic materials overlaying natural clays, sands, gravels, and claystone-shale bedrock materials. Topsoil depths are highly variable due to the steep slopes and rock outcroppings.

#### **4.0 Utilized Project BMPs**

There will be both structural and non-structural BMPs implemented for this Project of which are outlined in the following sections. The SWMP drawing (part of the approved drawing set) is included in Appendix A as part of the overall SWMP report. It should be noted that stormwater runoff from the Project site is routed through the Overlook Park Subdivision project site where construction has to date started and stormwater BMPs have already been implemented as part of its SWMP. Stormwater runoff from the Project site will be additionally treated and managed as it makes its way through the Overlook Park Subdivision BMPs.

The BMPs are to be installed where indicated on the plan set and per CDOT specifications where applicable. Four Points is utilizing the CDOT technical specifications Section 208 Erosion Control and the CDOT Pocket handbook to direct the Contractor on proper installation and implementation of the BMPs for the Project. Deviations from CDOT specifications shall first be approved by the Administrator under the Contractors discretion.

It is not expected that concrete will be poured and/or dedicated asphalt batch plants will exist on site at anytime during construction activities for the access road. It is also not expected that dewatering will be necessary at any point during construction. This SWMP will be updated accordingly to include provision regarding concrete washouts, asphalt/concrete batch plants, and dewatering if necessary.

#### **4.1 Structural BMPs**

Structural BMPs are defined as a stationary and permanent BMP that is designed, constructed and operated to prevent or reduce the discharge of pollutants in stormwater. The following structural BMPs shall be installed and implemented for erosion control and site stormwater management.

Sedimentation Basins – A temporary sedimentation basin was installed at the west end of the Overlook Park Subdivision project site. It collects and treats runoff from approximately 37 acres of area of which includes runoff area from the Project. Sedimentation basin design and sizing was performed in accordance with Steamboat Springs Standard Specifications. It is sized for the 100-year rainfall event. 100-year storage volume for the basin equates to approximately 45,000 ft<sup>3</sup>.

- An additional sedimentation basin identified on the site management plan as a water quality pond shall be utilized as an additional BMP. The basin will eventually become a permanent detention pond as required for the Project. The current capacity of the pond is approximately 32,000 ft<sup>3</sup>. A temporary 4" drainage pipe was installed underneath the temporary access road to skim water from the surface of the pond.
- The sedimentation basin outlets shall be protected with the use of riprap, erosion control bails, and/or silt fence or combination thereof. Sedimentation basins shall act as a final treatment of stormwater site runoff and shall be used in combination with other stormwater BMPs on both project sites.

Silt Fence – to be installed along the lower portion of the slopes as indicated on the plans. In some instances, it may be necessary to implement a double line of silt fence as an additional safeguard.

Straw Wattles/Erosion Control Bales and/or Gravel Ditch Checks – one or a combination of shall be installed perpendicularly along existing and proposed ditches that flow offsite or onsite. Straw wattles shall also be installed around any soil stockpile or staging area created.

Vehicle Tracking Control – has been installed at the end of current paving of Gloria Gossard Parkway which shall be the primary access point for the site. Material consists of 1”-2” of crushed stone supplied from a local quarry. Depth of stone shall be no less than 6”.

#### **4.2 Non-Structural BMPs**

Non-structural BMPs are defined as institutional and pollution-prevention practices designed to prevent or minimize pollutants from entering stormwater runoff and/or reduce the volume of stormwater requiring management. The following non-structural BMPs shall be implemented as part of the Project.

Parking Restrictions – vehicular traffic including primarily cars and light trucks used by crews, sub-contractors, inspectors, and other site personnel shall be restricted from driving on muddy and bare ground in an effort to reduce tracking onto adjacent roadways.

Periodic Inspections of Equipment – shall be performed to identify any potential fluid leaks including but not limited to gasoline/diesel, oil, antifreeze, brake fluid, power steering fluid, and hydraulic fluid. If a leak is found, the leak shall be contained, addressed, and a spill kit shall be utilized to clean up any spills.

Earthen Material Storage – which includes stockpiling of topsoil and general fill soil as part of the Project shall follow CDOT stockpiling management requirements. Topsoil and general fill soil shall be contained with silt fence at the toe of the stockpile. Topsoil stockpiles shall be seeded with a Routt County native grass mixed as specified by the Routt County natural resources extension office.

Construction and Building Material Storage – Building and construction materials shall be stored in the stockpiling and staging areas indicated on the civil drawings. Materials shall be covered and tied down as necessary to prevent airborne debris.

Temporary Seeding – At any time during grading processes, disturbed surfaces shall be stabilized with temporary seeding if they are inactive for a period of 30 days or longer. If a period of 30 days does not occur during transition from grading operations to civil improvements (e.g. wet utility installation, dry utility installation, base course and asphalt installation, etc), temporary seeding shall not be applied, and installation of BMPs shall continue to protect the site until final stabilization occurs.

Secondary Containment – containers, materials, and small motorized equipment containing liquids and chemicals (both liquid and solid) shall be stored in acceptable containment units as a safeguard against chemical spills. This primarily includes gasoline, oil, kerosene, fertilizers and pesticides but could include any number of non-hazardous fluids and solids. Secondary containment BMPs shall be capable of holding 110% of the volume of the largest container.

Spill Kits – shall be stored where potential chemical pollutants are located. Several kits shall be provided if there are multiple storage areas on site. Construction employees shall be trained to use spill kits as necessary. The Contractor shall follow the manufacturer’s suggested methods for cleanup and disposal.

Dust Control – shall consist of multiple control measures including:

- Applying water via sprayer or similar method shall be performed as needed to control construction related dust and particulates on disturbed roads and surface areas.
- Limiting vehicle speeds to 15 MPH on the project site.
- Revegetating and temporary seeding on areas not utilized for more than 15 days.
- Establishing gravel tracking pads at project site entrances.
- Temporary seeding and stabilizing with netting on stockpiles.

- Cleaning off paved adjacent roadways with water truck and hose.

Education – pertaining to BMP implementation shall be provided to construction personnel by the SWMP Administrator as necessary to ensure compliance with state and local standards.

### **4.3 Stormwater BMP Construction Phasing**

The following section provides a breakdown of the aforementioned structural and non-structural BMPs to be implemented during the phases of construction which include:

1. Before Grading,
2. During Grading,
3. During Construction, and
4. Final Stabilization

#### **4.3.1 Before Grading**

Sediment and erosion control BMPs that shall be established prior to ground-disturbing activities include:

- Construction entrances, staging areas, laydown and material storage areas, waste container, and temporary lavatories on site (some already established as part of the Overlook Park project).
- Preliminary erosion and sediment control measures as indicated on the site management plans including silt fence, straw wattles, and ditch checks. Already established as part of the Overlook Park project includes vehicle tracking control at site access, sedimentation basins, silt fence along the limits of disturbance, and gravel ditch checks.

#### **4.3.2 During Grading**

Sitework and grading will primarily consist of:

1. Topsoil stripping/stockpiling,
2. preliminary grading, and
3. cut/fill earthwork.

As sitework and grading progresses, BMPs will be modified and added as necessary to comply with state and local regulations. BMPs to be established during earthwork and grading activities shall include, but are not necessarily limited to:

- Additions and/or modifications of structural BMPs including; silt fence, straw wattles and bails, sedimentation basins, erosion control blankets, and vehicle tracking control.
- Non-structural BMPs including; parking restrictions, temporary seeding, equipment inspections for leaks and spills, proper soil stockpiling practices, providing secondary containment for chemicals, establishing spill kit locations, street cleaning, dust control, and BMP education.

#### **4.3.3 During Construction**

Construction related activities will primarily consist of:

1. Final grading and establishment of drive and swales,
2. final roadbase installation, and
3. installation and establishment of proposed water quality detention pond.

There will likely be an overlap of sitework and construction related activities. As construction activities start and progress, BMPs already established will be evaluated and modified as necessary. BMPs required for the grading phase may pertain to the construction phase as well. Additional BMPs to be implemented during construction activities include, but again, are not necessarily limited to:

- Proper construction and building material storage practices, secondary containment, spill kits, street cleaning, dust control, and BMP education.

#### **4.3.4 Final Stabilization**

Following construction activities, the site shall be properly stabilized and temporary erosion control BMPs shall be removed only after final stabilization is achieved and approved by the City of Steamboat Springs. Final stabilization shall be considered achieved when all soil-disturbing activities at the site have been completed and a uniform (i.e., evenly distributed, without large bare areas) perennial vegetative cover has been established on all unpaved areas that shall remain undisturbed for 30 days or more. The vegetative cover must have a density of at least 80 percent of the native background vegetative cover for the area. For those areas not covered by permanent structures, an equivalent permanent stabilization measure (such as the use of riprap or geotextiles) may be used.

### **5.0 Active Construction Component**

The following sections describe the potential pollution sources, erosion and sediment control measures, pollution prevention measures, and specifications to be used during Project construction. As the Project progresses, both structural and non-structural BMPs shall be observed and evaluated for effectiveness. The SWMP and BMPs shall be updated and implemented based on performance.

#### **5.1 Potential Pollutant Sources from Construction Activities**

Potential pollutant sources include sediment-laden runoff from land disturbance activities and oil/petroleum associated with construction equipment. Sediment shall be retained on site through the implementation of the previously mentioned BMPs as indicated on the plans as well as in drainage sensitive areas. The site contractor shall have spill clean-up supplies available to contain potential spills associated with their vehicles and equipment. On-site vehicles shall be monitored for leaks and receive regular maintenance to reduce the chance of leakage. Petroleum products shall be stored in tightly sealed, clearly labeled containers. Preferably, the containers shall be stored in a covered truck or trailer that provides secondary containment for the products (e.g. double wall containers). Fuel storage and fueling of construction equipment shall not take place within 50 feet of any stream bank, wetland, water supply well, spring, or other waterbody.

#### **5.2 Stabilized Construction Entrances Specifications**

A temporary construction ingress/egress pad shall be used to minimize the amount of sediment transported off site and onto public road surfaces or other paved areas by construction equipment or vehicles. See the SWMP drawings for additional information regarding location.

#### **5.3 Sediment and Dust Control Specifications for Sheet Flow Areas and Stockpiles**

Sheet flow runoff from Project-disturbed areas shall be managed by silt fence. Stockpiles of topsoil and fill shall be managed with the use of silt fence installed at the base of the toe. If necessary, topsoil stockpiles shall be stabilized with a native fast-growing Rye mix. See the SWMP drawings for additional information regarding location and installation details.

Stockpiles pose a source of dust and particulate generation. Stockpiles not stabilized with temporary seeding shall be properly stabilized with the use of tarps, erosion control blankets, straw blankets, or combination thereof.

#### **5.4 Sediment Control Specifications for Concentrated Flow Areas**

Sediment control measures for concentrated flow areas shall include straw wattles, straw bale barriers, sedimentation basins and rip-rap, which shall filter and slow the velocity of stormwater runoff. See the SWMP drawings for additional information regarding location and installation details.

#### **5.5 Runoff Control Measures**

The runoff control features to be used for the Project are shown on SWMP drawings and shall include silt fence along the perimeter and downslope of disturbed areas and straw wattles and straw bale barriers in areas of concentrated flow and sedimentation basins just before runoff is discharged offsite. These control features shall be installed prior to the start of earth-disturbing activities. These measures shall be installed and maintained in accordance with this SWMP and guidelines provided in the CDOT specifications section 208.

#### **5.6 Stormwater Outlet Protection Specifications**

Rip-rap and/or gravel shall be used to protect stormwater outlet locations. These locations are shown on the SWMP drawings, and the protection measures shall be installed and maintained in accordance with both the specifications and applicable guidelines provide in CDOT specifications section 208.

#### **5.7 Seasonal Temporary Surface Stabilization Methods**

In areas where soil disturbance activity has temporarily or permanently ceased, the application of soil stabilization measures must be initiated within thirty (30) days from the date the current soil disturbance activity ceased. Disturbed areas shall be seeded and mulched as necessary in accordance with the seeding and mulching specifications for the City of Steamboat Springs.

#### **5.8 Permanent Surface Stabilization Specifications**

The Project shall be considered permanently stabilized when all soil-disturbing activities at the site have been completed and a uniform (e.g. evenly distributed, without large bare areas) perennial vegetative cover with a density of 80 percent of the native background vegetative cover for the area has been established in all areas not covered by other permanent ground covers (e.g., pavement, crushed rock, structures). All disturbed areas including slopes, open spaces, and established swales shall be seeded with a Native Mountain Seed Mix by local supplier Windemere or approved equal, except where other surfacing is shown on the Site Plans. Revegetation shall consist of applying nitrogen-based fertilizer at the rate of approximately 1 pound per 1,000 square feet. All final seeding shall be stabilized with the use of straw blanket or approved equal. Fertilization, seeding, and stabilization shall be performed as soon as possible at the pre-existing access road in the south-east corner of the site.

#### **5.9 Material Handling and Spill Prevention Plan**

Construction and landscaping materials that pose a potential contamination threat to stormwater (e.g. petroleum products, hydraulic fluids, fertilizers, detergents, and solvents) shall be managed to minimize exposure to stormwater. Materials shall be kept in secure containers and properly labeled. Copies of the

Material Safety Data Sheets (MSDS) shall be maintained on site. Solid and liquid waste (including sediment, asphalt, floating debris, paper, plastic, fabric, and construction and demolition debris) and other wastes shall be disposed of properly and in accordance with applicable disposal requirements. Waste containers shall be inspected regularly. Waste material shall be collected and stored in a secure container and removed from the Project site. Solid or liquid wastes shall not be disposed on site.

In addition to the material management practices previously discussed, the following spill control and cleanup practices shall be used to prevent stormwater pollution in the event of a spill:

1. On-site personnel shall be made aware of cleanup procedures and the location of spill cleanup equipment;
2. Spills shall be contained and cleaned up immediately after discovery;
3. Manufacturer methods for spill cleanup of a material shall be followed as described on the material's MSDS;
4. Materials and equipment needed for cleanup procedures shall be kept readily available on the site, either at an equipment storage area or on contractors' trucks; equipment to be kept on the site shall include, but not be limited to, brooms, dust pans, shovels, granular absorbents, sand, sawdust, absorbent pads and booms, plastic and metal trash containers, gloves, and goggles;
5. Toxic, hazardous, or petroleum product spills required to be reported by regulation shall be documented to the appropriate federal, state, and local agencies; and
6. Spills shall be documented and a record of the spills shall be kept with this SWMP.

A guidance for reporting spills under the Colorado Water Quality Control Act and Discharge Permits is included in Appendix C along with a copy of the Five-day Spill Report Form to be completed in the event of a reportable spill. If a spill is reportable, the contractor's superintendent shall immediately contact the Owner, Administrator, and the following authorities:

Federal:

National Response Center: (800) 424-8802 or (202) 267-2675

EPA Region 8 Hotline: (800) 227-8917

State:

CDPHE Spill Hotline (877) 518-5608

## **6.0 Inspections and Recordkeeping**

The Project area shall be routinely inspected by the Contractor's SWMP Administrator (Four Points Surveying and Engineering) to ensure that all prescribed BMPs, both structural and non-structural, are properly implemented and maintained. Specifically, these inspections will be performed by Joe Wiedemeier, P.E. He is a certified preparer of stormwater management plans and a qualified compliance inspector of stormwater for the State of Colorado.

The need for additional BMPs or maintenance identified during inspections shall immediately be brought to the attention of the Contractor in which they shall address issues at the earliest possible time. Records of the BMPs and maintenance required, date remedies were made, and approval of such shall be documented in the inspection reports. Details pertaining to inspections are described below.

### **6.1 Inspections Timing and Scope**

The SWMP BMPs outlined in this report shall be inspected by qualified personnel at a minimum once every 14 calendar days and within 24 hours of any storm that causes roughening of the disturbed ground surface. The post storm event inspections can be utilized as a 14 days inspection. If snow cover exists over an extended period of time or construction activity is put on hold, inspections shall still be performed. The scope of inspection shall include the construction site perimeter, material and waste storage areas, offsite and onsite flow discharge locations, vehicle storage areas, drainage ditches, site entrances and all other associated BMPs.

### **6.2 Reporting**

Hard copies of inspection forms shall be completed during each inspection. A blank copy of the inspection form is provided in Appendix D. Hard copies shall be scanned to Four Points server the day each inspection is completed. Inspection reports shall be kept by permittee and retained for a minimum of three years from the final stabilization date. A picture record shall be utilized to document the implementation of BMPs as well as for initial and final stabilization.

### **6.3 State and Local Regulation Compliance**

The SWMP Administrator shall ensure compliance with applicable State and/or local storm water permit and other regulatory requirements.

### **7.0 SWMP and Inspection Training**

The SWMP Administrator shall have sufficient training and experience related to responsibilities and requirements for SWMP inspections. The SWMP Administrator shall inform the Contractor of the necessary steps required for proper SWMP implementation. Training shall cover information and procedures contained in the SWMP and shall be conducted on a bi-annual basis, as new employees/workers are hired, or deemed as necessary by the SWMP Administrator.

**Appendix A – SWMP Drawings**



**GRADING AND EROSION CONTROL NOTES:**

1. ALL SLOPES GREATER THAN 2H:1V SHALL HAVE SOIL RETENTION BLANKETS PLACED AFTER SEEDING.
2. ALL GRADING SHALL OCCUR WITHIN THE PROPERTY LIMITS. WHERE OFF-SITE WORK IS APPROVED, WRITTEN PERMISSION IS OF THE ADJACENT PROPERTY OWNER MUST BE OBTAINED PRIOR TO CONSTRUCTION.
3. IF TOPSOIL DEPTHS ENCOUNTERED EXCEED THOSE ANTICIPATED BY THE CONTRACT DOCUMENTS, THE CONTRACTOR SHALL IMMEDIATELY NOTIFY THE ENGINEER FOR VERIFICATION AND MODIFICATION TO DESIGN.
4. THE CONTRACTOR IS RESPONSIBLE FOR ALL STORM WATER MANAGEMENT AND EROSION CONTROL DURING CONSTRUCTION OF THE PROJECT. THE CONTRACTOR SHALL COMPLY WITH CITY, COUNTY, STATE AND FEDERAL LAWS AND PERMITS FOR THE CONTROL OF STORM WATER AND EROSION CONTROL.
5. THE CONTRACTOR IS RESPONSIBLE FOR INSTALLING, INSPECTING AND MAINTAINING ALL NECESSARY EROSION AND SEDIMENT CONTROL DURING CONSTRUCTION AND REMOVING EROSION CONTROL WHEN PROJECT IS COMPLETE.
6. NO WORK SHALL OCCUR IN WETLANDS OR FLOOD PLAINS WITHOUT APPROPRIATE PERMITS. ANY WORK SHALL BE COMPLETED IN ACCORDANCE WITH THE ISSUED PERMITS.
7. ALL AREAS DISTURBED DURING CONSTRUCTION SHALL BE REVEGETATED AT THE COMPLETION OF CONSTRUCTION .
8. ALL DRAINAGE SWALES AND DITCHES SHALL BE GRASS-LINED UNLESS NOTED OTHERWISE
9. THE CONTRACTOR SHALL CLEAN ALL EXISTING AND PROPOSED CULVERTS AND STORM SEWERS PRIOR TO SUBSTANTIAL COMPLETION INSPECTIONS.
10. THE CONTRACTOR SHOULD WORK IN A MANNER THE MINIMIZES THE POTENTIAL FOR EROSION.
11. ALL DISTURBED AREAS THAT DO NOT RECEIVE PAVEMENT, LANDSCAPE TREATMENT OR ROCK TREATMENT, SHALL RECEIVE TOPSOIL, REPLACEMENT AND GRASS VEGETATION AS A MINIMUM.
12. FLARED END SECTIONS AND RIPRAP NEEDED AT ALL PIPE OUTFALLS.
13. THE LIMITS OF LAND DISTURBANCE ARE IDENTIFIED BY THE BOUNDS OF THE PROPOSED GRADING, ACCESS ROAD, AND STRAW WATTLES. NO OTHER LAND DISTURBANCE ACTIVITIES SHALL OCCUR

**CONSTRUCTION SITE MANAGEMENT NOTES:**

1. THIS PLAN SHALL BE KEPT ON SITE AT ALL TIMES AND UPDATED TO REFLECT ANY CHANGES.
2. CONCRETE WASTE AND WASHOUT WATER FROM MIXING TRUCKS SHALL BE CONTAINED ON SITE, REMOVED FROM THE SITE, AND PROPERLY DISPOSED. MATERIALS SHOULD NOT ENTER STATE WATERS.
3. CONTRACTOR IS RESPONSIBLE FOR INSTALLING AND MAINTAINING TEMPORARY EROSION AND SEDIMENT CONTROL DURING CONSTRUCTION AND ESTABLISHING ANY REQUIRED PERMANENT BEST MANAGEMENT PRACTICES (BMPs).
4. CONTRACTOR IS RESPONSIBLE FOR COMPLYING WITH ALL LOCAL, STATE, AND FEDERAL LAWS. IN ADDITION CONTRACTOR MUST OBTAIN REQUIRED PERMITS.
5. CLEARING OR GRADING SHALL NOT BEGIN UNTIL ALL SEDIMENT CONTROL DEVICES HAVE BEEN INSTALLED.
6. THE CONTRACTOR SHALL PROMPTLY REMOVE ALL SEDIMENT, MUD, AND CONSTRUCTION DEBRIS THAT MAY ACCUMULATE IN THE RIGHT OF WAY, PRIVATE PROPERTY, OR WATER WAYS AS A RESULT OF THE CONSTRUCTION ACTIVITIES.
7. ALL INGRESS, EGRESS POINTS AND VEHICLE ACCESS POINTS ONTO DISTURBED SITE MUST BE STABILIZED WITH A VEHICLE TRACKING CONTROL PAD. ACCESS SHALL ONLY BE VIA APPROVED LOCATIONS AS SHOWN ON APPROVED CSMP.
8. SOIL STABILIZATION MEASURES SHALL BE IN PLACE AND AREAS ARE TO BE REVEGETATED: (1) FOR STOCKPILES, IF INACTIVE FOR MORE THAN 30 DAYS (2) FOR AREAS OF LAND DISTURBANCE WITHIN ONE GROWING SEASON.
9. INLET PROTECTION SHALL BE INSTALLED IN CONJUNCTION WITH STORM DRAIN INLETS WHERE DRAINAGE AREA IS NOT VEGETATED.
10. BMPs SHALL BE USED, MODIFIED, AND MAINTAINED WHENEVER NECESSARY TO REFLECT CURRENT CONDITIONS. BMPs SHALL BE INSPECTED WEEKLY AND AFTER EVERY PRECIPITATION EVENT. ACCUMULATED SEDIMENT SHALL BE REMOVED FROM BMPs WHEN THE SEDIMENT LEVEL REACHES 1/2 THE HEIGHT OF THE BMP.
11. EMERGENCY ACCESS MUST BE KEPT OBSTACLE FREE AND PASSABLE AT ALL TIMES.
12. FOR ANY WORK TO BE DONE IN THE RIGHT OF WAY, COORDINATE WITH THE CITY CONSTRUCTION SITE MANAGER REGARDING SPECIAL PERMITTING.
13. WHERE REQUIRED AS PART OF THE ROW PERMIT OR WHERE SITE WORK AFFECTS THE PEDESTRIAN OR VEHICLE TRAVEL WAY, TRAFFIC CONTROL SHALL BE INSTALLED. ALL TRAFFIC CONTROL SHALL BE IN ACCORDANCE WITH THE MANUAL ON UNIFORM TRAFFIC CONTROL DEVICES, LATEST EDITION.
14. SIDEWALKS ADJACENT TO CONSTRUCTION SITES SHALL BE MAINTAINED. FOR PUBLIC USE, BY THE CONTRACTOR. IN AREAS WHERE CONSTRUCTION IS TAKING PLACE NEXT TO THE SIDEWALK AND OVERHEAD HAZARDS ARE POSSIBLE, SITE IS RESPONSIBLE FOR INSTALLING AND MAINTAINING SIDEWALK PROTECTION.
15. NO TRUCK DELIVERIES PRIOR TO 8:00 A.M., AND AFTER 5:00 P.M., MONDAY THROUGH FRIDAY.

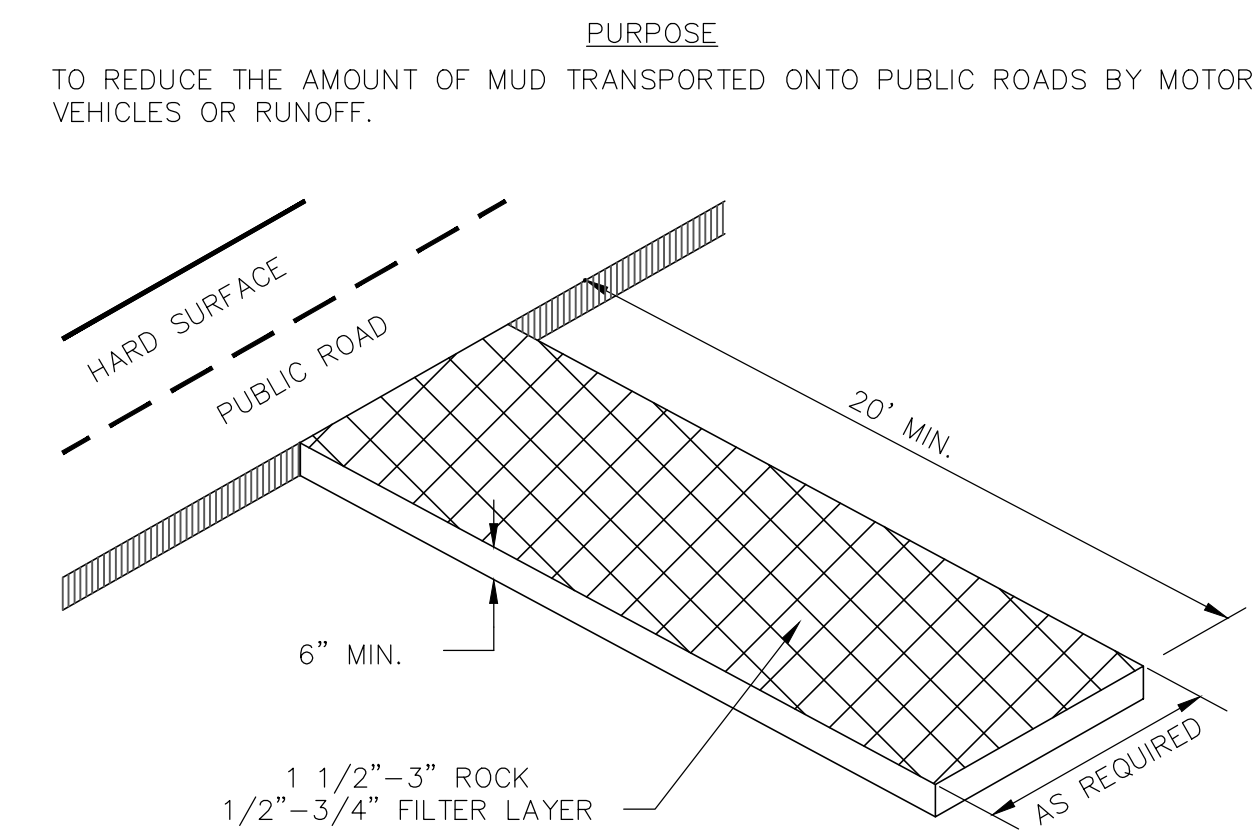

**VEHICLE TRACKING CONTROL**  
N.T.S.

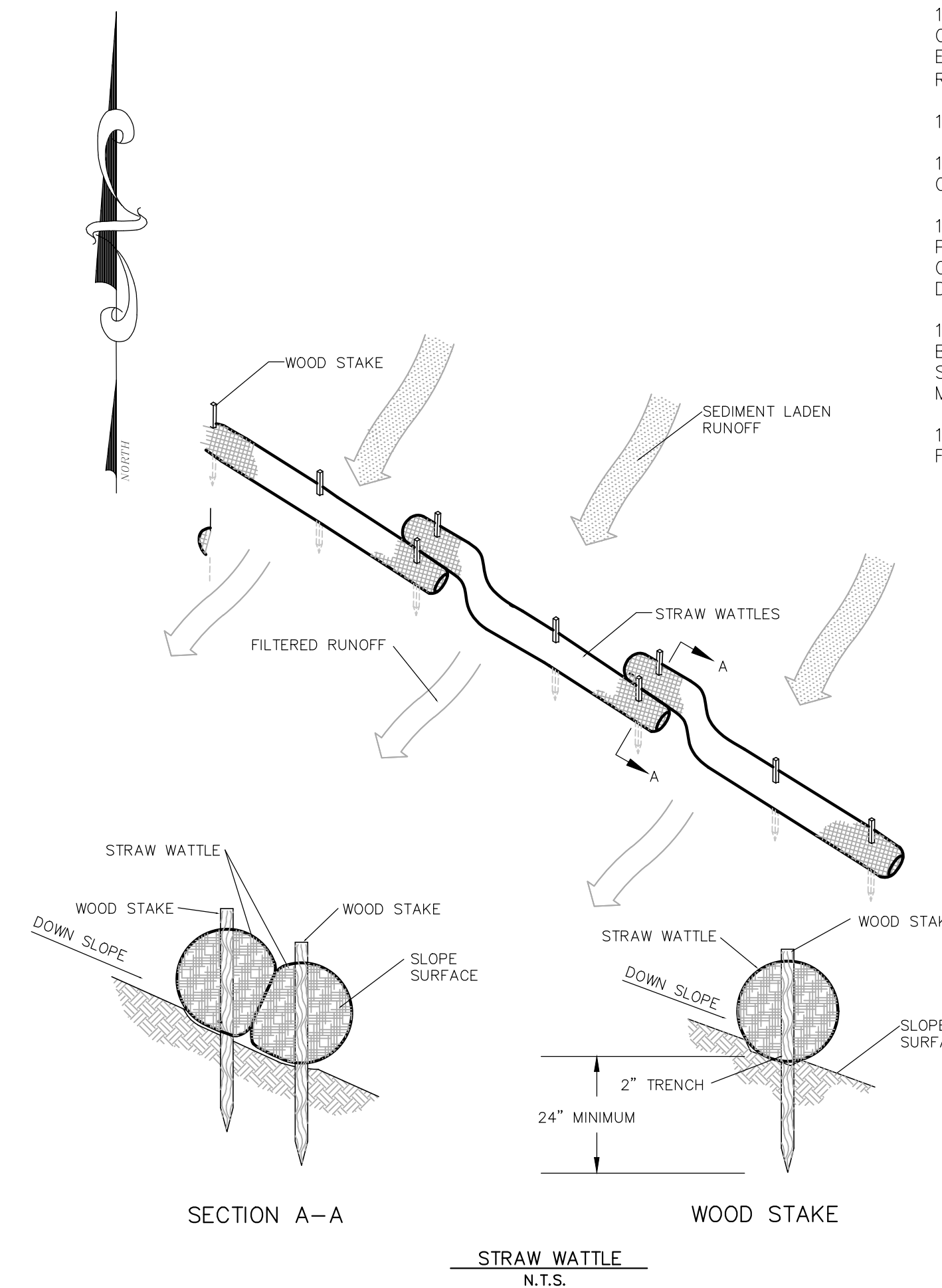

**STRAW WATTLE**  
N.T.S.

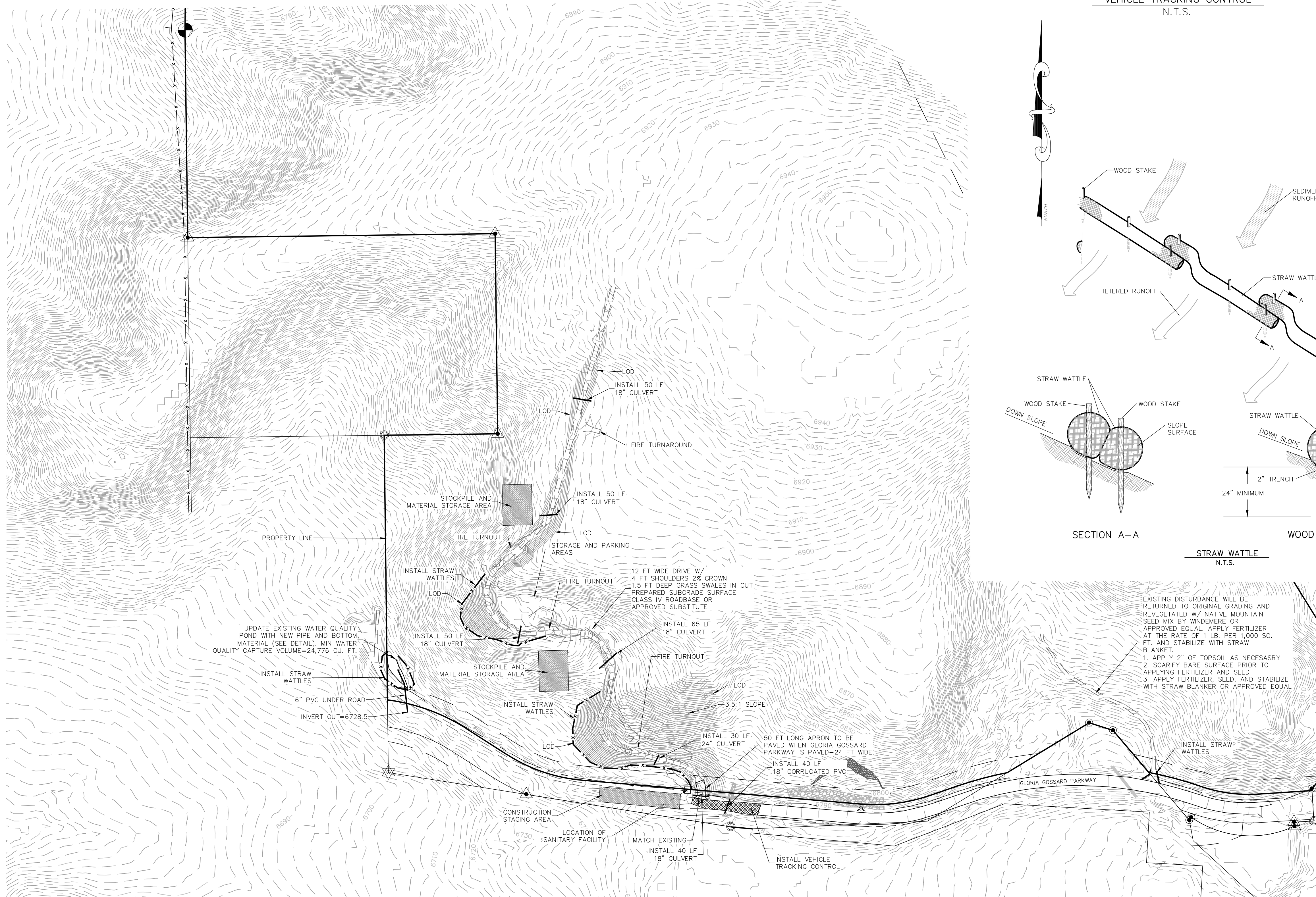

**LEGEND**

—	PROPERTY BOUNDARY
- - -	ADJACENT PROPERTY BOUNDARY
- - - -	EXISTING EASEMENT
- - - - -	EXISTING EDGE OF ASPHALT
- - - - -	EXISTING 2 FT CONTOUR
- - - - -	EXISTING 10 FT CONTOUR
- - - - -	PROPOSED 2 FT CONTOUR
- - - - -	PROPOSED 10 FT CONTOUR
- - - - -	PROPOSED BUILDING
- - - - -	PROPOSED DECK
- - - - -	PROPOSED EDGE OF CONCRETE
-x-x-x-	EXISTING SEWER
-x-x-x-	PROPOSED SEWER
-x-x-x-	EXISTING WATER
-x-x-x-	PROPOSED WATER
- - - - -	PROPOSED CENTER OF ROAD
- - - - -	PROPOSED EDGE OF ASPHALT
- - - - -	DITCH
- - - - -	CULVERT

**LOT 1, WEST ACRES RANCH SUBDIVISION**  
Steamboat Springs, CO 80487

**STORMWATER MANAGEMENT PLAN**

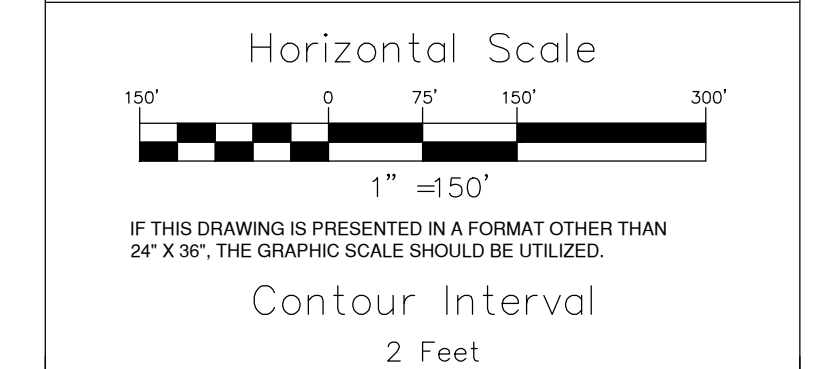

NO.	DATE	REVISIONS	INT.
1	6-19-18	PER CITY REVIEW AND COMMENT	JLW

DATE: 3-18-2018 DESIGN: MDM  
JOB NO. 1670-001 DRAFTED: MDM  
DWG. NAME: REVIEW: WNM

**Four Points Surveying and Engineering**

440 S. Lincoln Ave, Suite 4B  
P.O. Box 775966  
Steamboat Springs, CO 80487  
(970)-871-6772  
wnmpeps@gmail.com

**Appendix B – Spill Reporting**

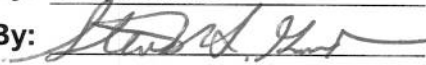

WATER QUALITY  
CONTROL  
DIVISION

Policy No: WQE-10  
Initiated By: Dave Akers  
Approved By:   
Effective Date: 3/1/08  
Revision No.: \_\_\_\_\_  
Revision Date: \_\_\_\_\_

**Guidance for Reporting Spills under the Colorado Water Quality  
Control Act and Colorado Discharge Permits**

**I. Purpose**

To provide guidance on applicable Colorado reporting requirements pursuant to § 25-8-601(2), C.R.S., that pertains to spills or discharges that may cause pollution of State waters. This guidance does not relieve an entity of any other statutory or regulatory requirements applicable to a spill. Facilities possessing a Colorado Discharge Permit System (CDPS) permit should follow applicable permit terms and conditions regarding spill reporting and response. This guidance is not intended to supersede or modify such permit terms and conditions or the applicable statute and regulations. This guidance does not limit the existing rights or responsibilities of persons with respect to spill reporting. For example, persons retain the right and responsibility to determine in the first instance whether a particular spill is covered by an existing permit or may cause pollution to State waters (i.e., surface or ground waters).

**II. Statutory Requirement Addressed**

Colorado Water Quality Control Act - Spill Reporting Requirements - § 25-8-601(2), C.R.S.

“Any person engaged in any operation or activity which results in a spill or discharge of oil or other substance which may cause pollution of the waters of the state contrary to the provisions of this article as soon as he has knowledge thereof, shall notify the division of such discharge.”

State waters means any and all surface and subsurface waters which are contained in or flow in or through this state, but does not include waters in sewage systems, waters in treatment works of disposal systems, waters in potable water distribution systems, and all water withdrawn for use until use and treatment have been completed (§ 25-8-103 (19), C.R.S.).

Examples of State waters include, but are not limited to, perennial streams, intermittent or ephemeral gulches and arroyos, ponds, lakes, reservoirs, irrigation canals or ditches, wetlands, stormwater conveyances (when they discharge to a surface water), and groundwater.

**III. Policy/Applicability**

The Division distinguishes between reporting requirements for spills that occur with respect to activities that result in a discharge that is authorized under a CDPS permit and those that are not. For non-permitted activities, or in the case of an activity where a permit does not address reporting of or response to a given spill, the Division recommends that the responsible person(s) take the following actions:

1. Immediately report spills that may result in a non-permitted discharge of pollutants to State waters to the Environmental Release and Incident Reporting Line at 1-877-518-5608;
2. Include the following information, if available, when notifying the Division of a spill:
  - a. The name of the responsible person and, if not reported by that person, the name of the person reporting the spill and the name of the responsible person if known;
  - b. An estimate of the date and time that the spill began or the actual date and time, if known;

- c. The location of the spill, its source (e.g., manhole, tanker truck), and identification of the type of material spilled (e.g., untreated wastewater, biosolids, specific chemical);
- d. The estimated volume of the spill and, if known, the actual date and time the spill was fully controlled/stopped.
- e. Whether the spill is ongoing and, if it is, the rate of flow and an estimate of the time that the spill will be fully controlled, if known;
- f. Measures that are being or have been taken to contain, reduce, and/or clean up the spill;
- g. A list of any potentially affected area and any known downstream water uses (e.g., public water supplies, irrigation diversions, public use areas such as parks or swim beaches) that will be or have been notified; and
- h. A phone number and e-mail to contact a representative of the responsible person that is in charge of the response. Where a non-responsible person is reporting the spill, they are encouraged, but not required, to provide contact information.

Reporting and management of spills that occur with respect to activities resulting in a discharge authorized under a permit should be performed in accordance with the specific requirements of that permit. If the permit does not provide specific reporting or management response requirements for a given spill that may pollute State waters, the Division recommends that the responsible person report the spill in accordance with the procedures listed above.

This guidance only addresses reporting requirements under the Division's authority. The person or entity engaged in any operation or activity that results in a spill is responsible for any other applicable reporting requirements associated with the spill to other regulatory agencies.

Section 25-8-601(2), C.R.S. only addresses spill reporting to the Division. Section 25-8-202(7), C.R.S. provides certain water quality responsibilities to other state "implementing agencies." The Division's position is that, where a spill to the ground that may impact ground water only is fully and timely reported to an implementing agency having jurisdiction over that spill, the intent of section 601(2) has been fulfilled, and the spill need not also be reported to the Division. The Division suggests that the responsible person confirm with the implementing agency that a spill falls under the jurisdiction of the implementing agency at the time it is reported in order to avoid possible legal liability should it fall under the Division's jurisdiction.

#### **IV. Division Examples of Non-Reportable Spills**

The Division has identified the following examples of types of spills that are considered "non-reportable" under § 25-8-601(2), C.R.S. Documentation of such spills, including the information listed in section III.2.a – III.2.f above, should be maintained by the responsible person for Division review for a period of three years.

1. A spill to a generally impervious surface or structure (e.g., paved street/parking lot, storm sewer, warehouse floor, manhole, vault, concrete basement), or onto soils, that is fully contained in/on the impervious surface/structure or soils, or that is managed in a manner so that it will not reach State waters at the time of the spill or in the future. Such spills that are cleaned up within 24 hours will be considered by the Division to have no potential to reach State waters. However, even if such spills are not cleaned up within 24 hours, the responsible person may be able to "fully contain" or otherwise manage a spill such that it will not reach State waters. Where there is a sump pump present in a basement to which a spill occurred, the responsible person must establish that the pump did not discharge to State waters during the time between the start of the spill and the completion of clean-up in accordance with best management practices.
2. A spill or discharge that is managed consistent with best management practices that are established in accordance with a CDPS discharge permit or any Water Quality Control Commission-adopted control regulation related to spill management or reporting.
3. A spill of potable water from a public water system that does not reach surface waters.



# Five day reporting form

Incident / spill / sanitary sewer overflow release

*Use this form to report incidents impacting waters of the state*

The Water Quality Control Division distinguishes between reporting requirements for incidents that occur at entities operating under a Colorado Discharge Permit System (CDPS) permit and those resulting from non-permitted activities.

**Permitted activities** - Reporting and management of non-compliance incidents and spills that occur as a result of permitted activities should be performed in accordance with the specific requirements in the notifications section of your permit. You may use this form to submit the information requested in the permit.

**Non-permitted activities** - In the case of an activity where a permit does not address reporting of, or response to, a given spill please submit a written summary of the event, your response, and clean up efforts to the division within five working days of the date of the event. This form is provided for your convenience. If you have any questions please contact the division's field services staff person assigned to your spill case.

Prior to the five working day deadline you may request an extension to submit the report if needed for sampling analysis or other reasons. To request an extension please send an email to the division's field services staff person assigned to your spill case or to the spill administrator. The field services contact list is available at: [www.colorado.gov/cdphe/wq-inspection-services-contact-us](http://www.colorado.gov/cdphe/wq-inspection-services-contact-us).

Please send the completed form or report with signature to the division's field services spill administrator:

Michelle Thiebaud  
 222 S. Sixth Street, 232  
 Grand Junction, CO 81501

Telephone: 970-248-7150  
 Fax: 970-248-7198  
 Email: [michelle.thiebaud@state.co.us](mailto:michelle.thiebaud@state.co.us)

1. Incident background information					
Incident/spill number (division provided)		Date of event		County	
Type of incident / spill / SSO (check one)					
<input type="checkbox"/> Sanitary sewer overflow	<input type="checkbox"/> Potable water/reuse water/ reclaimed water		<input type="checkbox"/> Biosolids		
<input type="checkbox"/> Wastewater treatment plant bypass or upset (authorized outfall point)	<input type="checkbox"/> Petroleum product		<input type="checkbox"/> Oil or gas field production spill		
<input type="checkbox"/> Wastewater treatment plant spill or overflow (other than outfall)	<input type="checkbox"/> Chemical		<input type="checkbox"/> Other		
Estimated volume released					
Size and depth of area affected					
Contact information					
Potentially responsible party contact name					
Potentially responsible party company/agency name					
CDPHE Permit number and facility name (if applicable)					
Email address				Phone	
2. Incident information: Please provide the following information.					
A. Describe incident including source, cause, and location (e.g. address, latitude/longitude).					
B. Material released, e.g. untreated wastewater, specific chemical or product, biosolids. Please attach the OSHA Material Safety Data Sheets for any and all chemicals or products in spill or release.					

C. Actual or estimated duration of the event and time spill was fully controlled/stopped. If release is still occurring, the date and time the release is expected to be stopped.			
D. Describe measures taken or planned to contain, reduce, and clean up spill or release.			
E. Describe steps taken or planned to prevent reoccurrence.			
<b>3. Incident impact to state waters (As defined in § 25-8-103(19), C.R.S.).</b> Examples of state waters include: stormwater conveyances (when they discharge to surface water), perennial streams, intermittent or ephemeral gulches, ditches, ponds, lakes, reservoirs, irrigation canals, wetlands and groundwater.			
A. Did flow or materials reach surface water of the state? If so, identify the water body or bodies and describe the path of flow. What quantity of material reached the surface waters and what was the resulting impact?			
B. Did flow or materials reach groundwater of the state? If so, identify the water body or bodies and describe the path of flow. If yes, what quantity of material reached the ground or groundwater and what was the resulting impact?			
C. Did the incident include any of the following? If so, please include additional details below.			
<input type="checkbox"/> Chemical release	<input type="checkbox"/> Fish kill	<input type="checkbox"/> Sheen on water	
D. Were any water quality samples or other samples taken? If so, please describe sampling process, sampling location(s) in relationship to the incident, i.e. up/down stream and attach results.			
<b>4. Incident impact to areas or water users</b>			
A. Describe the potential impact of the incident/spill/SSO to public use areas or downstream water users. This includes parks and swim beaches or public water system sources and irrigation diversions.			
B. Were the impacted area users and downstream water users notified and describe the method of notification, e.g. signs posted, via phone.			
C. List any downstream users who were notified.			

I hereby certify that the information presented above is accurate and complete.			
<b>Signature</b>	<b>Name and title</b>	<b>Company, organization</b>	<b>Date</b>

**Appendix C – BMP Inspection Form**



