

FOUNDATION NOTES:

- 1) ALL FOOTINGS MUST BE PLACED ON VIRGIN SOIL OR STRUCTURAL APPROVED FILL AS DETERMINED BY THE SOILS ENGINEER
- 2) ALL FOOTINGS MUST BE FREE OF LOOSE SOIL
- 3) 28 DAY MINIMUM CONCRETE STRENGTH
 F. FOOTINGS = 3000 PSI
 W. WALLS = 3500 PSI
 S. SLABS = 4000 PSI
- 4) REBAR SHALL MAINTAIN A MINIMUM COVER OF:
 1" 3" IN ALL AREAS WHERE CAST AGAINST EARTH
 1/2" WHEN CAST AGAINST FORMS
 1" FOR SLABS
- 5) REBAR SHALL BE A MINIMUM OF GRADE 60
- 6) MINIMUM REBAR SPICE LENGTH OF 40 BAR DIAMETERS
- 7) FOUNDATION FOOTINGS & WALLS ARE BASED ON THE FOLLOWING:
 SOILS REPORT: #08-7346
 PROVIDED BY: NORTHWEST COLORADO CONSULTANTS, INC.
 DATED: MAY 8, 2008
 EQUIVALENT FLUID PRESSURE: 55 PCF
- 8) OVER-EXCAVATION AND RECOMPACTED STRUCTURAL FILL BELOW ALL SLABS ARE REQUIRED BY THE GEOTECHNICAL ENGINEER.
 AN OPEN-HOLE INSPECTION IS REQUIRED AT THE TIME OF EXCAVATION BY THE GEOTECHNICAL ENGINEER.
- 9) ALL FOOTING AND WALL CONCRETE SHALL BE PLACED CONTINUOUSLY AND BE MECHANICALLY CONSOLIDATED. NO HORIZONTAL COLD JOINTS ARE ALLOWED.
- 10) ANCHOR BOLTS TO BE PLACED AT 4'-0" O.C. AND HAVE A MIN EMBEDMENT LENGTH OF 8" MINIMUM OF 2 BOLTS PER PLATE.
- 11) CEMENT SHALL BE TYPE II MODIFIED
- 12) MAXIMUM SLUMP OF 7"
- 13) ALL CONCRETE SHALL BE PROTECTED FROM FREEZING FOR A MINIMUM OF 36 HOURS
- 14) ALL CONCRETE SLABS SHALL HAVE CONTROL JOINTS CUT 1" DEEP @ 12'-0" O.C. MAX. WHERE POSSIBLE, ALIGN CONTROL JOINTS WITH COLUMN CENTERLINES AND RE-ENTRANT CORNERS.

DESIGN CRITERIA: CODE REFERENCES:

- FLOOR LOADS:
 LIVE 40 PSF
 DEAD 20 PSF
 60 PSF
- ROOF LOADS:
 SNOW 123 PSF
 DEAD 15 PSF
 55 PSF
- WIND DESIGN:
 115 MPH (V_W), EXPOSURE 'C'
- SEISMIC:
 DESIGN CATEGORY 'C'
- FROST DEPTH: 48"
- IBC 2018
 IRC 2018
 AISI 13th EDITION
 ACI 308.05
 MSJC 2008
 AWC, NDS 2005

HELICAL PIER LEGEND:

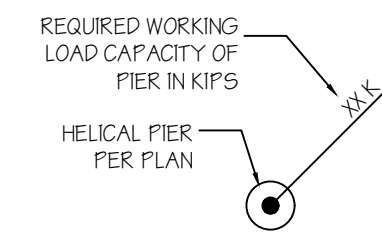

HELICAL PIER NOTES:

1. ALL PIERS MUST BE CORROSION PROTECTED BY HOT DIPPED GALVANIZATION
2. THE HELICAL PIER SELECTION WILL CONSIDER DESIGN LOAD PLUS A SAFETY FACTOR, SOIL PARAMETERS AND THE INSTALLATION TORQUE VS. CAPACITY PER THE MANUFACTURER'S RECOMMENDATIONS. ALL HELICAL PIERS SHALL COMPLY WITH 100-AC3088, IBC 1903.3.3.13 AND 1810.4.11.
3. A CERTIFIED HELICAL PIER CONTRACTOR SHALL INSTALL THE HELICAL PIERS. PROOF OF CURRENT CERTIFICATION MUST BE PROVIDED BY THE HELICAL PIER CONTRACTOR. ALL WORK AS DESCRIBED HEREIN SHALL BE PERFORMED IN ACCORDANCE WITH THE APPLICABLE SAFETY CODES IN EFFECT AT THE TIME OF INSTALLATION. THE PIERS AS SPECIFIED SHALL CONFORM TO S903 STANDARD BUILDING CODE, BOCA NATIONAL CODE, OR IBCO UNIFORM BUILDING CODE. AN OFFICIAL EVALUATION REPORT WITH ASSIGNED NUMBER SHALL BE PRESENTED UPON REQUEST TO THE OWNER AND/OR THEIR REPRESENTATIVE.
4. THE HELICAL PIER DRILL LOG SHALL BE SUBMITTED TO THE ENGINEERING LOFT, P.L.L.C. AND BE AVAILABLE ON SITE FOR INSPECTIONS.
5. CONTINUOUS INSPECTION OF THE HELICAL PIER INSTALLATION SHALL BE PROVIDED BY A QUALIFIED INSPECTOR PER 2018 IBC 1705.9.

- 5.1 SPECIAL INSPECTIONS:
 5.1.1 CONTRACTOR SHALL VERIFY WITH THE LOCAL BUILDING DEPARTMENT ABOUT REQUIRED SPECIAL INSPECTIONS FOR ALL STRUCTURAL MATERIALS.
- 5.1.2 THE SPECIAL INSPECTOR SHALL BE A QUALIFIED PERSON WHO SHALL DEMONSTRATE HIS COMPETENCE, TO THE SATISFACTION OF THE BUILDING OFFICIAL FOR INSPECTION OF THE PARTICULAR TYPE OF CONSTRUCTION OR OPERATION REQUIRING SPECIAL INSPECTION. DUTIES AND RESPONSIBILITIES OF THE SPECIAL INSPECTOR:
 5.1.3.1 OBSERVE THE WORK ASSIGNED FOR CONFORMANCE WITH THE APPROVED DESIGN DRAWINGS AND SPECIFICATIONS. THE INSPECTOR MAY NOT ALTER, MODIFY, ENLARGE OR WAIVE ANY OF THE REQUIREMENTS OF THE DOCUMENTS. FURNISH INSPECTION REPORTS TO THE OWNER, THE BUILDING OFFICIAL, AND THE PROFESSIONAL OF RECORD. ALL DISCREPANCIES SHALL BE BROUGHT TO THE IMMEDIATE ATTENTION OF THE CONTRACTOR FOR CORRECTION. THEN, IF UNCORRECTED, SUBMIT A COMPLETE LIST TO ALL OUTSTANDING DISCREPANCIES ON A WEEKLY BASIS TO THE OWNER, THE BUILDING OFFICIAL, AND THE PROFESSIONAL OF RECORD UNTIL ALL CORRECTIONS HAVE BEEN COMPLETED. SUBMIT A FINAL SIGNED REPORT STATING WHETHER THE WORK REQUIRING SPECIAL INSPECTIONS WAS, TO THE BEST OF THE INSPECTOR'S KNOWLEDGE, IN CONFORMANCE WITH THE APPROVED PLANS AND SPECIFICATIONS AND THE APPLICABLE WORKMANSHIP PROVISIONS OF THE CODE.
- 5.1.3.2
- 5.1.3.3

BASE PLATE SCHEDULE				
NOTATION	SIZE	DETAIL	BOLT EMBEDMENT	
△	3/4"x6"x12"	(2) 3/4"x8"x10" LONG TITEN HD ANCHOR BOLTS	8" MIN	
△	1"x8"x12"	(2) 1"x8"x10" LONG TITEN HD ANCHOR BOLTS	8" MIN	
△	2"x12"x12"	(4) 2"x8"x10" LONG TITEN HD ANCHOR BOLTS	8" MIN	

NOTE:
 1. ALL ANCHOR BOLTS SHALL BE A307 J-BOLTS
 2. ANCHOR BOLTS SHALL HAVE 2" MIN EDGE DISTANCE

REVIEWED FOR CODE COMPLIANCE
 06/23/2023

The ENGINEERING LOFT
 15875 FAIRWAY DRIVE
 BUENA VISTA, CO 81211
 720-491-1611
 CHRISTINA@ENGINEERINGLOFT.COM

RICHEY LIVE/WORK UNITS
 LOT 3, COPPER RIDGE BUSINESS PARK SUBDIVISION
 STEAMBOAT SPRINGS, CO 80487

FOUNDATION & FIRST FLOOR FRAMING PLAN

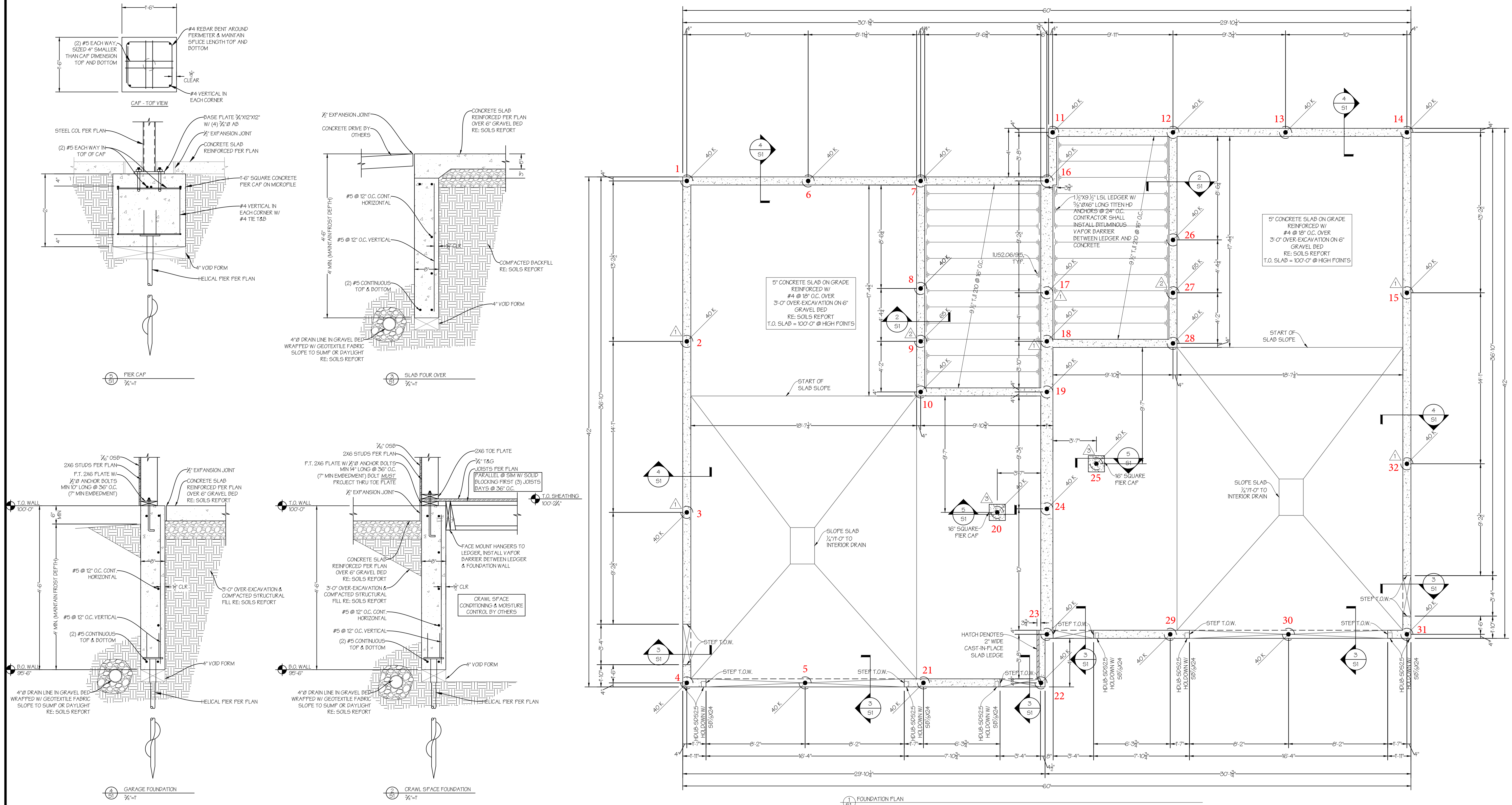

PRELIM DATE: 7.18.22
 RELEASE DATE: 7.19.22
 REVISION DATE: 8.29.22
 4.10.23

SHEET:
S1

PROJECT NUMBER: 21160

FRAMING NOTES:

1. LUMBER

- a. ALL LUMBER, SHEATHING, AND ENGINEERED WOOD COMPONENTS SHALL CONFORM TO GUIDELINES FROM THE AWC NDS
- b. ALL STRUCTURAL FRAMING INCLUDING; HEADERS, TOP PLATES, JOISTS, AND RAFTERS SHALL BE HEM FIR #2 OR BETTER.
- c. ALL STUDS LESS THEN OR EQUAL TO 10'-0" SHALL BE HEM FIR STUD GRADE OR BETTER. ALL STUDS MORE THAN 10'-0" SHALL BE HEM FIR #2 OR BETTER.
- d. ALL HEAVY TIMBER MEMBERS 6" AND GREATER SHALL BE DF-L #1 OR BETTER
- e. ALL JOISTS ARE TO BE INSTALLED ACCORDING TO THE MANUFACTURERS INSTRUCTIONS. IF VARIATIONS BETWEEN THOSE SPECIFICATIONS AND THIS PLAN ARE FOUND CONTACT ENGINEER FOR CLARIFICATION. SUBSTITUTIONS OF JOISTS BETWEEN MANUFACTURERS ARE ALLOWED BUT MUST BE AN APPROVED EQUAL.
- f. ALL LUMBER IN CONTACT WITH CONCRETE OR EXPOSED TO WEATHER SHALL BE PRESSURE TREATED.
- g. ALL EXTERIOR GLU-LAM BEAMS TO BE ALASKAN CEDAR 20F-V12
- h. ALL OTHER GLU-LAM BEAMS TO BE DOUGLAS FIR 24F-V4

2. STEEL

- a. ALL STEEL BEAMS TO BE ASTM A992 STEEL SHAPES (Fy=50 ksi)
- b. ALL ROUND STEEL POSTS TO BE ASTM A53 (GRADE B) STEEL COLUMNS. NOMINAL COLUMN DIAMETERS ARE LISTED (3"Ø-3 1/2"Ø, 3 1/2"Ø-4"Ø, 4"Ø-4 1/2"Ø, 5"Ø-5 1/2"Ø).
- c. ALL SQUARE TUBE SHAPES SHALL BE ASTM A500 (GRADE B)
- d. ENDS OF POSTS SHALL HAVE PLATES WELDED TO THE POST. THE BASE WILL BE BOLTED TO THE CONCRETE WITH A MIN OF (2) 3/8" EXPANSION BOLT
- e. ALL OTHER SHAPES (PLATES, ANGLES, CHANNELS) TO BE ASTM A36
- f. ALL STEEL TO STEEL CONNECTIONS SHALL BE FULLY WELDED AT ALL CONTACT SURFACES WITH A MIN OF A 3/8" FILLET WELD OF E70xx ELECTRODE.
- g. STEEL BEAM SUPPLIERS TO FURNISH BEAM BOLT TOGETHER CONNECTIONS WITH A MIN OF 3/8" PLATE AND (5) 3/4" Ø A325 BOLTS.
- h. MINIMUM BEARING FOR STEEL BEAMS IS 3".
- i. GROUT ALL BEAM POCKETS SOLID AFTER BEAM HAS BEEN SET AND SHIMMED.
- j. ALL BOLTS, NUTS AND WASHERS TO BE MINIMUM OF A307.

3. CONNECTIONS

- a. ALL HANGER CALL OUTS CORRESPOND TO PRODUCTS MANUFACTURED BY SIMPSON STRONG-TIE CORPORATION
- b. HANGERS FOR T JOISTS TO BE SIZED PER MANUFACTURER RECOMMENDATIONS
- c. PROVIDE MIN OF H2ST TRUSS CLIPS AT ALL TRUSS BEARING POINTS. PROVIDE DOUBLE CLIPS AT MULTIPLE PLY TRUSSES. OTHER ATTACHMENT MAY BE REQUIRED BY THE TRUSS DESIGNER.
- d. SILL PLATES SHALL BE ATTACHED W/ 1/2" Ø ANCHOR BOLTS AT FOUR FEET MAXIMUM ON CENTER, 12" FROM ALL CORNERS, MINIMUM 2 BOLTS PER PLATE.
- e. TO PROVIDE LATERAL SUPPORT, THE ALL WOOD PLATES, WHICH REST ON STEEL BEAMS, TO THE STEEL BEAM WITH X-2F-47 P8923 POWDER ACTUATED FINIS AT 32" O.C. OR 3/8" THRU BOLTS @ 36" O.C. INTO THE TOP FLANGE OF THE BEAMS.

4. MINIMUM MEMBER SIZES

- a. ALL LOAD BEARING HEADERS ARE TO BE (2) 2x10'S UNLESS NOTED OTHERWISE.
- b. FOR 2x4 WALLS ALL HEADERS ARE TO BE SUPPORTED BY A MINIMUM OF (1) 2x4 TRIMMERS AND (1) 2x4 KING STUD AT EACH JAMB, UNDO. PROVIDE MINIMUM (2) 2x4 KING STUDS AT EACH JAMB FOR OPENINGS 6'-0" TO 10'-0".
- c. FOR 2x6 WALLS ALL HEADERS ARE TO BE SUPPORTED BY A MINIMUM OF (1) 2x6 TRIMMER AND (1) 2x6 KING STUD AT EACH JAMB, UNDO. PROVIDE MINIMUM (2) 2x6 KING STUDS AT EACH JAMB FOR OPENINGS 6'-0" TO 10'-0".
- d. ALL WALLS SHALL BE FRAMED IN ACCORDANCE WITH TABLE R602.3.1 ALL RAKE WALLS SHALL BE FRAMED FULL HEIGHT TO THE BOTTOM OF EITHER LOOKOUT RAFTERS OR GABLE END TRUSS WITH 1" FLEECE STUDS. BLOCKING MAY BE REQUIRED ON WALLS TALLER THAN 12'-0".
- e. ALL POINT LOADS SHALL BE CARRIED DOWN AND BEAR DIRECTLY ON THE FOUNDATION WALL OR BEAM. EACH POST MUST INCREASE BY ONE PLY FOR EACH LEVEL CARRYING THE POINT LOAD. SQUASH BLOCKS ARE REQUIRED BETWEEN FLOORS
- f. ALL BEARING LENGTHS FOR WOOD BEAMS SHALL NEVER BE LESS THAN 1/2" AT THE ENDS OF BEAMS. BEARING ACROSS THE FULL WIDTH OF THE BEAM IS REQUIRED.
- g. TYPICAL ROOF OVER FRAMING SHALL BE 2x6 AT 24" ON CENTER AND BE POSTED DIRECTLY TO TRUSSES OR RAFTERS BELOW. MAX SPAN FOR THE 2x6 MEMBERS IS 6'
- h. ALL MULTIPLE MEMBER LVL'S SHALL BE ASSEMBLED ACCORDING TO THE SUPPLIERS RECOMMENDATIONS
- i. 2-PLY POSTS SHALL BE NAILED TOGETHER W/ TWO ROWS OF 16d NAILS @ 16" O.C. ADJACENT NAILS SHALL BE DRIVEN FROM OPPOSITE SIDES OF THE COLUMN
- j. 3-PLY POSTS SHALL BE NAILED THE SAME AS THE 2-PLY W/ THE THIRD PLY NAILED TO THE 2-PLY W/ (2) 16d NAILS @ 6" O.C.
- k. 4 & 5-PLY POSTS SHALL BE NAILED THE SAME AS THE 3-PLY W/ C516 STRAPS TOP & BOTTOM.
- l. 6 & 7-PLY POSTS SHALL BE NAILED THE SAME AS THE 3-PLY W/ C516 STRAPS TOP, CENTER, & BOTTOM.
- m. EXTERIOR WALL SHEATHING SHALL BE 1/2" OSB NAILED WITH 8d NAILS, OR 15/16" LONG X 1/2" WIDE STAPLES AT 12" O.C. IN FIELD AND 6" O.C. AT EDGE. ALL EDGES MUST BE BLOCKED AND NAILED.
- n. ZIP SYSTEM SHEATHING SHALL BE INSTALLED PER MANUFACTURERS SPECIFICATIONS. PANELS SHALL BE FASTENED WITH 10d SHANK NAILS @ 7" O.C. EDGE AND 12" O.C. FIELD NAILING. THE NAILS SHALL HAVE 15" MINIMUM PENETRATION INTO FRAMING. ALL PANEL EDGES MUST BE BLOCKED & NAILED.
- o. ROOF SHEATHING SHALL BE 1/2" OSB W/ 8d NAILS AT 6" O.C. EDGE AND 10" O.C. FIELD NAILING.
- p. FLOOR SHEATHING SHALL BE MINIMUM 1/2" OSB W/ 8d NAILS AT 6" O.C. EDGE AND 12" O.C. FIELD NAILING.
- q. INTERIOR WALL SHEATHING SHALL BE 1/2" DRYWALL W/ 1/4" X 16 DRYWALL SCREWS AT 7" O.C. ALL NAILING SHALL BE IN CONFORMANCE WITH IRC TABLE R602.3

5. GENERAL

- a. FRAMING CONTRACTOR IS RESPONSIBLE FOR COORDINATING LOCATION OF PLUMBING IN REFERENCE TO FLOOR FRAMING.
- b. AT FIRST FLOOR AND STRUCTURAL FLOOR, WHERE JOISTS RUN PARALLEL TO THE FOUNDATION WALLS, PROVIDE PERPENDICULAR SOLID BLOCKING AT 4'-0" ON CENTER FOR THE FIRST 3 BAYS.
- c. PROVIDE SOLID BLOCKING AT SUPPORTS BETWEEN TRUSSES TO PREVENT ROTATION
- d. PROVIDE SOLID BLOCKING AT ALL TRUSS RIDGES, HIPS, VALLEYS, AND DIVES.
- e. THE GENERAL CONTRACTOR SHALL VERIFY THE DIMENSIONS AND SITE CONDITIONS PRIOR TO START OF WORK. THE ARCHITECT AND STRUCTURAL ENGINEER SHALL BE NOTIFIED OF ANY DISCREPANCIES OR ERRORS.
- f. STRUCTURAL DRAWINGS ARE INTENDED TO BE USED WITH ARCHITECTURAL AND MECHANICAL DRAWINGS. CONTRACTOR IS RESPONSIBLE FOR COORDINATING SUCH REQUIREMENTS INTO THEIR SHOP DRAWINGS AND WORK.
- g. NO OPENINGS SHALL BE MADE IN ANY STRUCTURAL MEMBER WITHOUT THE WRITTEN APPROVAL OF THE PROFESSIONAL ENGINEER OF RECORD.
- h. NO CHANGE IN SIZE OR DIMENSION OF STRUCTURAL MEMBERS SHALL BE MADE WITHOUT THE WRITTEN APPROVAL OF THE PROFESSIONAL ENGINEER OF RECORD.
- i. OPENINGS 1'-4" AND LESS ON A SIDE ARE GENERALLY NOT SHOWN ON THE STRUCTURAL DRAWINGS. REFER TO ARCHITECTURAL AND MECHANICAL DRAWINGS FOR SUCH OPENINGS.
- j. THE CONTRACTOR IS RESPONSIBLE FOR LIMITING THE AMOUNT OF CONSTRUCTION LOAD IMPOSED UPON STRUCTURAL FRAMING. CONSTRUCTION LOADS SHALL NOT EXCEED THE DESIGN CAPACITY OF THE FRAMING AT THE TIME THE LOADS ARE IMPOSED.
- k. THE STRUCTURE IS DESIGNED TO FUNCTION AS A UNIT UPON COMPLETION. THE CONTRACTOR IS RESPONSIBLE FOR FURNISHING ALL TEMPORARY BRACING AND/OR SUPPORT THAT MAY BE REQUIRED AS THE RESULT OF THE CONTRACTOR'S CONSTRUCTION METHODS AND/OR SEQUENCES. DO NOT SCALE THESE DRAWINGS, USE DIMENSIONS.
- l. CONTRACTOR'S CONSTRUCTION AND/OR ERECTION SEQUENCES SHALL RECOGNIZE AND CONSIDER THE EFFECTS OF THERMAL MOVEMENTS OF STRUCTURAL ELEMENTS DURING THE CONSTRUCTION PERIOD.
- m. THE CONTRACTOR SHALL INFORM THE PROFESSIONAL OF RECORD IN WRITING OF ANY DEVIATION FROM THE CONTRACT DOCUMENTS. THE CONTRACTOR SHALL NOT BE RELIEVED OF THE RESPONSIBILITY OF SUCH DEVIATION BY THE PROFESSIONAL OF RECORD REVIEW OF SHOP DRAWINGS, PRODUCT DATA, ETC., UNLESS THE CONTRACTOR HAS SPECIFICALLY INFORMED THE PROFESSIONAL OF RECORD OF SUCH DEVIATION AT THE TIME OF SUBMISSION, AND THE PROFESSIONAL OF RECORD HAS GIVEN WRITTEN APPROVAL TO THE SPECIFIC DEVIATION.

MINIMUM LUMBER DESIGN PROPERTIES					
LVL	PSL	LSL	HF #2	HF STUD	DF-L #1
Fp (psi)	2600	2300	2325	850	675
E (10 ⁶ psi)	1.9	2.0	1.55	1.3	1.2
Fc (psi)	750	750	800	405	405
Fv (psi)	285	280	310	150	150

MULTIPLE LVL FASTENING	
2-PLY	(2) ROWS 5DS 7X3/4" @ 19.2" O.C.
3-PLY	(2) ROWS 5DS 7X3/4" @ 16" O.C. EACH SIDE
4-PLY	(2) ROWS 6X TRUSSLOK SCREWS @ 16" O.C. EACH SIDE

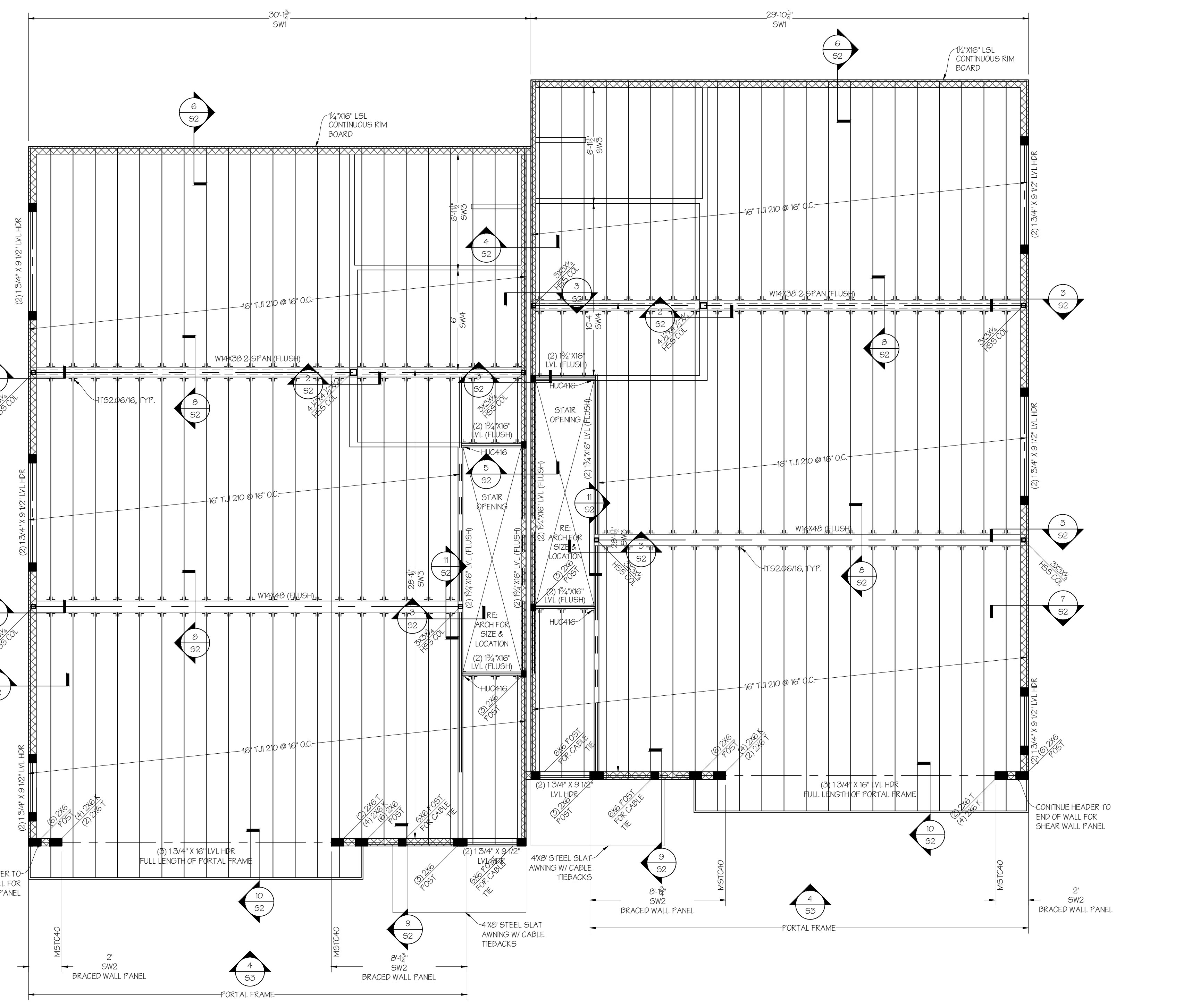
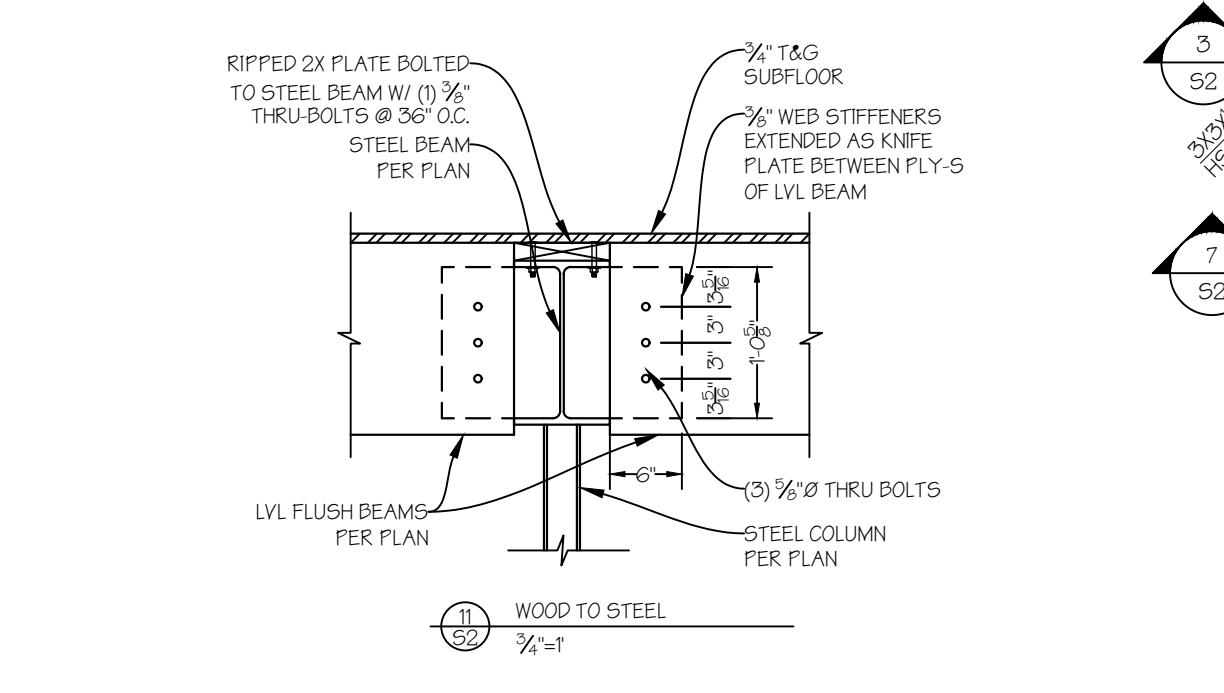
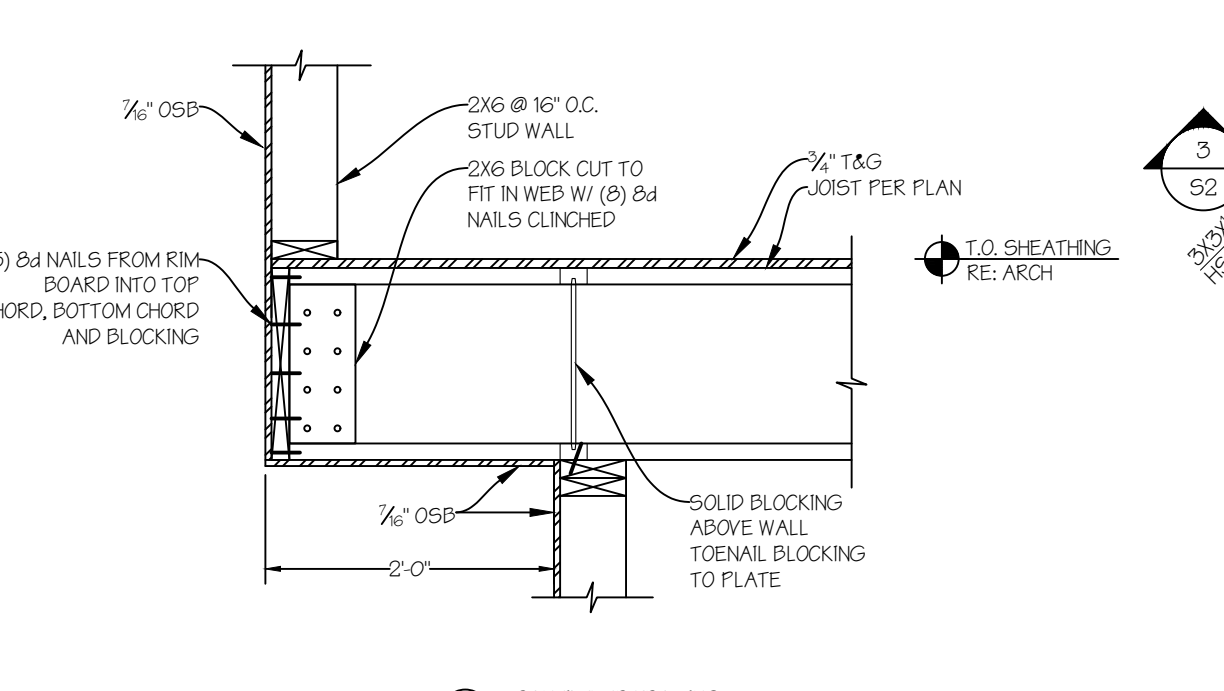
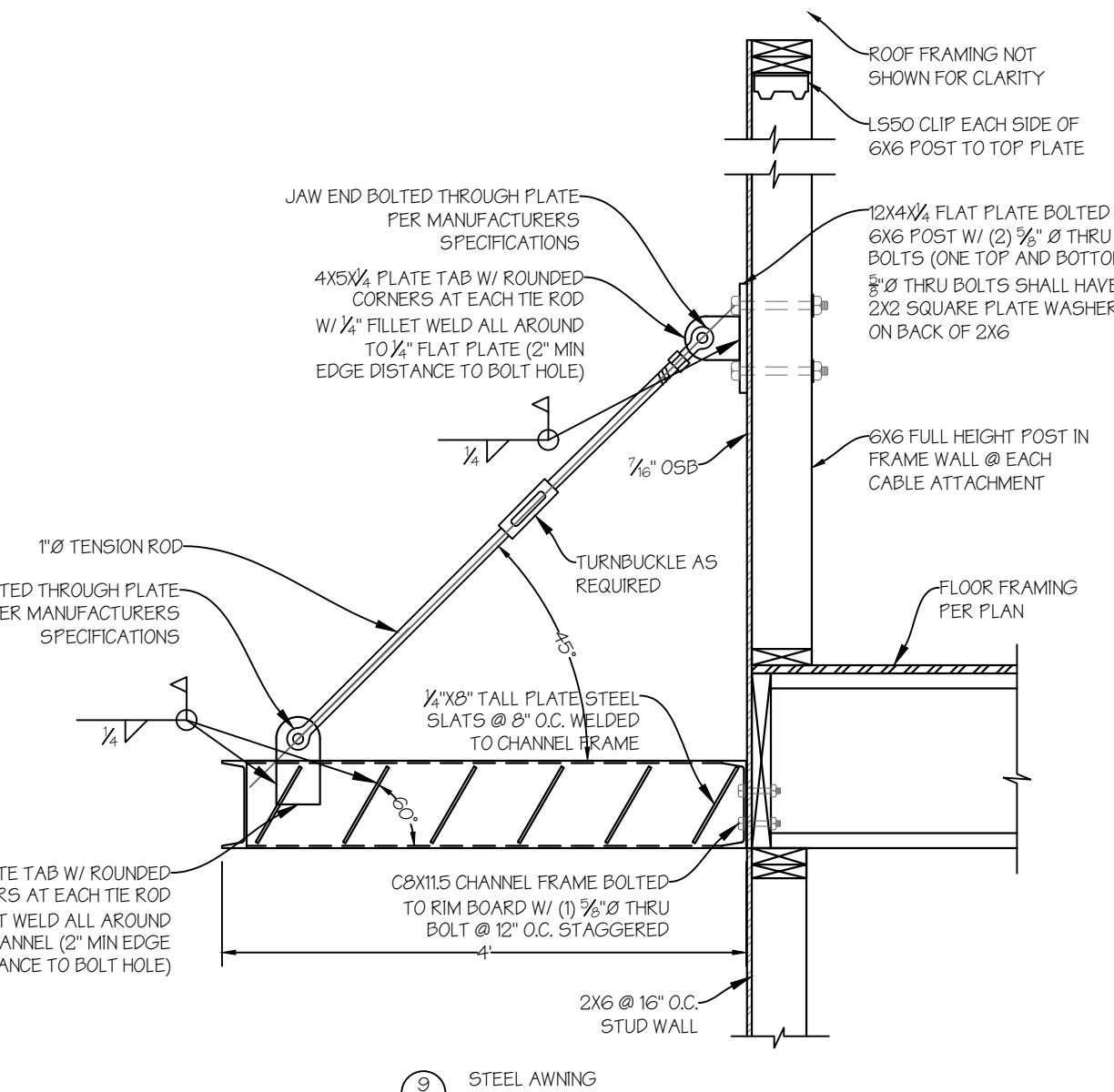
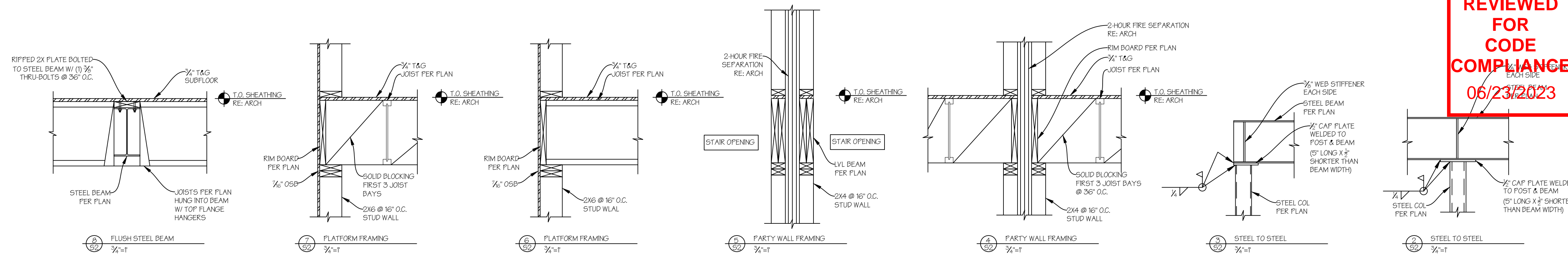

REVIEWED FOR CODE COMPLIANCE
 06/23/2023

The ENGINEERING LOFT
 15873 FAIRWAY DRIVE
 BUENA VISTA, CO 81211
 720.491.1611
 CHRISTINA@ENGINEERINGLOFT.COM

RICHEY LIVE/WORK UNITS
 LOT 3, COPPER RIDGE BUSINESS PARK SUBDIVISION
 STEAMBOAT SPRINGS, CO 80487
SECOND FLOOR FRAMING PLAN



PRELIM DATE: 7.18.22
 RELEASE DATE: 7.19.22
 REVISION DATE: 8.29.22
 4.10.23

SHEET:
S2

PROJECT NUMBER: 21160

